

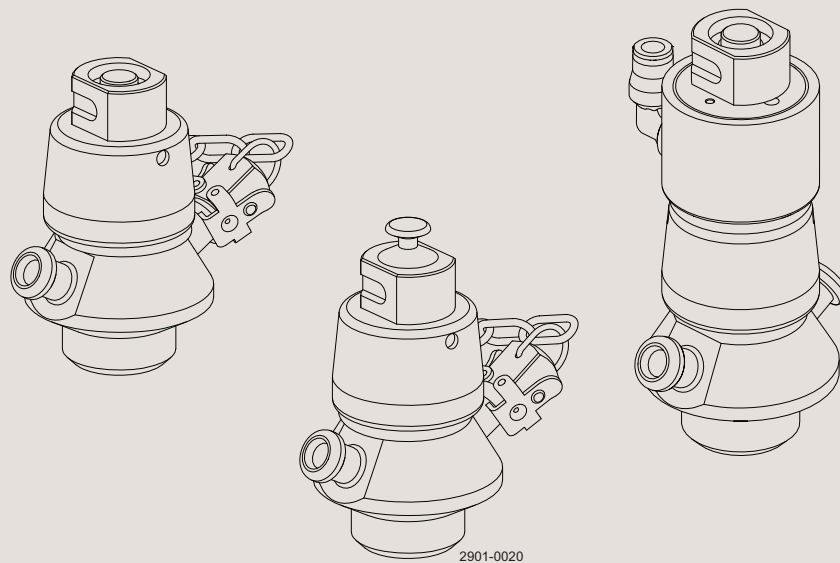

Instruction Manual

Alfa Laval SB Membrane Sample Valve



ESE02963-EN4

2018-05

Original manual



www.sks-online.com

The information herein is correct at the time of issue but may be subject to change without prior notice

1. EC Declaration of Conformity	4
2. Safety	5
2.1. Important information	5
2.2. Warning signs	5
2.3. Safety precautions	6
3. Installation	7
3.1. Unpacking/delivery	7
3.2. General installation	7
3.3. Valve assembly	8
3.4. Recycling information	10
4. Operation	11
4.1. Operation	11
4.2. Sterilisation with alcohol	12
4.3. Sterilisation with steam	13
4.4. Sampling	14
5. Maintenance	16
5.1. General maintenance	16
6. Technical Data	19
6.1. Technical data	19
7. Parts List and Service Kits	20
7.1. Membrane Sample Valve, manual	20
7.2. Membrane Sample Valve, manual & micro port	22
7.3. Membrane Sample Valve, pneumatic	24

1 EC Declaration of Conformity

The Designated Company

Alfa Laval Kolding A/S

Company Name

Albuen 31, DK-6000 Kolding, Denmark

Address

+45 79 32 22 00

Phone No.

hereby declares that

Valve

Designation

SB Membrane Sample Valve

Type

is in conformity with the following directives with amendments:

- Machinery Directive 2006/42/EC
- Regulation (EC) No. 1935/2004

The person authorised to compile the technical file is the signer of this document

Global Product Quality Manager
Pumps, Valves, Fittings and Tank Equipment

Title

Lars Kruse Andersen

Name

Kolding

Place

2015-06-02

Date

Signature



*Unsafe practices and other important information are emphasised in this manual.
Warnings are emphasised by means of special symbols.*

2.1 Important information

Always read the manual before using the valve!

WARNING

Indicates that special procedures must be followed to avoid serious personal injury.

CAUTION

Indicates that special procedures must be followed to avoid damage to the valve.

NOTE

Indicates important information to simplify or clarify procedures.

2.2 Warning signs

General warning:



Caustic agents:



2 Safety

All warnings in the manual are summarised on this page.

Pay special attention to the instructions below to avoid serious personal injury and damage to the valve.

2.3 Safety precautions

Installation:

Always read the technical data thoroughly (see chapter 6 Technical Data)
Always release compressed air after use.
Never touch the moving parts if the actuator is supplied with compressed air.
Never touch the valve or the pipelines when processing hot liquids or when sterilising.
Never dismantle the valve with the valve and pipelines under pressure.
Never dismantle the valve when it is hot.



Operation:

Never dismantle the valve with the valve and pipelines under pressure.
Never dismantle the valve when it is hot.
Always read the technical data thoroughly (see chapter 6 Technical Data)
Always release compressed air after use.
Never touch the valve or pipelines when processing hot liquids or when sterilising.
Never touch the moving parts if the actuator is supplied with compressed air.
Always rinse well with clean water after cleaning.



Always handle lye and acid with great care.



Maintenance:

Always read the technical data thoroughly (see chapter 6 Technical Data.)
Always release compressed air after use.
Never service the valve when it is hot.
Never service the valve with the valve and pipelines under pressure.
Never stick your fingers through the valve ports if the actuator is supplied with compressed air.
Never touch the moving parts if the actuator is supplied with compressed air.



Transportation:

Always ensure that compressed air is released.
Always ensure that all connections are disconnected before attempting to remove the valve from the installation.
Always drain liquid out of valves before transportation.
Always use predesigned lifting points, if available.

The instruction manual is part of delivery. Study the instructions carefully.
The items refer to the Parts List and Service Kits section.

3.1 Unpacking/delivery

Step 1

CAUTION

Alfa Laval cannot be held responsible for incorrect unpacking.

Check the delivery for:

1. Complete valve, manual or pneumatic
2. Membrane EPDM (white)
3. Membrane Silicone (transparent)

Instruction manual

Material certificate 3.1 acc. EN10204

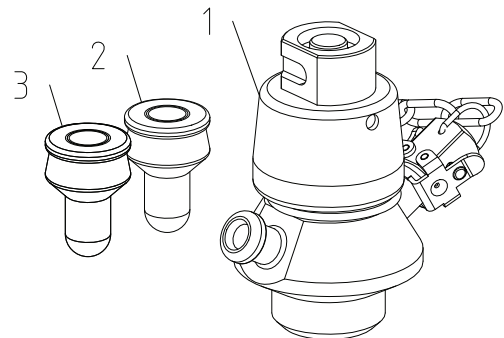

Step 2

Remove any packing materials from the valve/valve parts.
Inspect the valve/valve parts for visible transport damage.
Avoid damaging the valve/valve parts.

3.2 General installation

Step 1



Always read the technical data thoroughly.
See chapter 6 Technical Data



Always release compressed air from the actuator for force opening after use.

CAUTION

Alfa Laval cannot be held responsible for incorrect installation.

3 Installation

The instruction manual is part of delivery. Study the instructions carefully.
The items refer to the Parts List and Service Kits section.

3.3 Valve assembly

The valve body can be integrated into a tank, fitted on pipes or mounted with a BSP connection.
The valve must always be fitted so that the connections are placed vertically or the valve will not function properly.
Before welding type T and P, the valve must be disassembled so the seals, gaskets and membrane are not damaged by the heat.

Valve body - type T

For tank-mounted valves. It is important that the valve seat is not damaged by grinding or excessive heat.

- Pos 1 Tank wall
- Pos 2 Valve body - type T
- Pos 3 No grinding

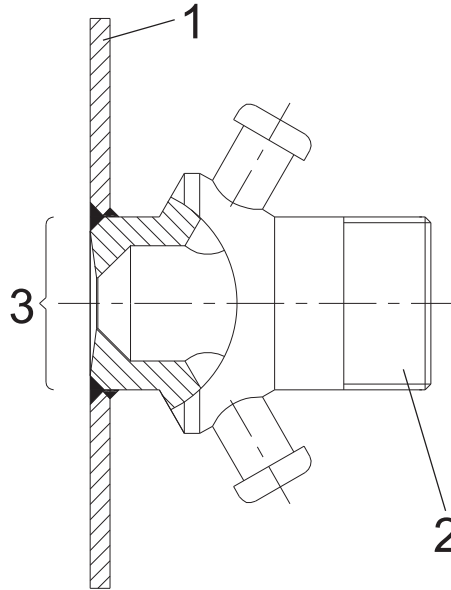

Valve body - type P

For pipe-mounted valves. It is important that the valve seat is not damaged by grinding or excessive heat.

- Pos 1 Valve body - type P
- Pos 2 Ensure flush welding

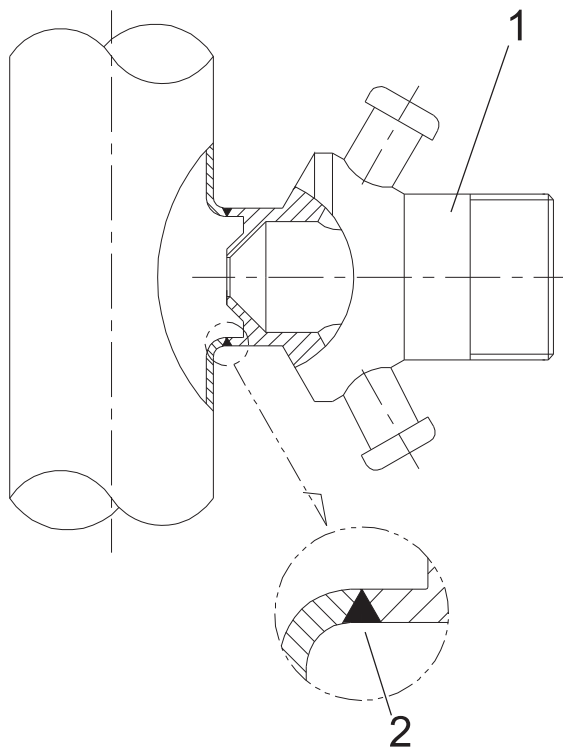

*The instruction manual is part of delivery. Study the instructions carefully.
The items refer to the Parts List and Service Kits section.*

Valve body - type S

Valves in the type-S execution come with a 3/8" BSP male thread. Ensure that the connection is not leaking.

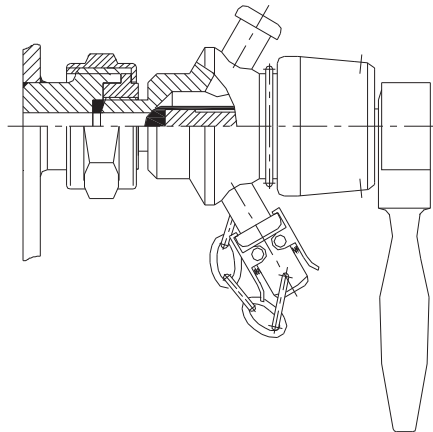

3 Installation

*The instruction manual is part of delivery. Study the instructions carefully.
The items refer to the Parts List and Service Kits section.*

3.4 Recycling information

Unpacking

- Packing material consists of wood, plastics, cardboard boxes and, in some cases, metal straps.
- Wood and cardboard boxes can be reused, recycled or used for energy recovery.
- Plastics should be recycled or burnt at an authorised waste incineration plant.
- Metal straps should be sent for material recycling.

Maintenance

- All metal parts should be sent for material recycling.
- Worn out or defective electronic parts should be sent to a licensed handler for material recycling.

Scrapping

- At the end of use, the equipment should be recycled according to relevant local regulations. As well as the equipment itself, any hazardous residue from the process liquid must be dealt with in a proper manner. When in doubt, or in the absence of local regulations, please contact your local Alfa Laval sales company.
-

The instruction manual is part of delivery. Study the instructions carefully.
The items refer to the Parts List and Service Kits section.

4.1 Operation

Step 1



Always read the technical data thoroughly.
See chapter 6 Technical Data



Always release compressed air after use.

CAUTION

Alfa Laval cannot be held responsible for incorrect operation.

Step 2



Never touch the valve or the pipelines when processing hot liquids
or when sterilising.

Burning hazard!



Step 3



Never touch the moving parts if the actuator is supplied with
compressed air.

Moving parts!



4 Operation

The instruction manual is part of delivery. Study the instructions carefully.
The items refer to the Parts List and Service Kits section.

4.2 Sterilisation with alcohol

Step 1

Always sterilise the valve before taking a sample.
Make sure that the valve is in the closed position before sterilisation.

Step 2

Sterilisation procedure:

1. Close the lower outlet of the valve with the clip-on cap and fill the valve with alcohol.

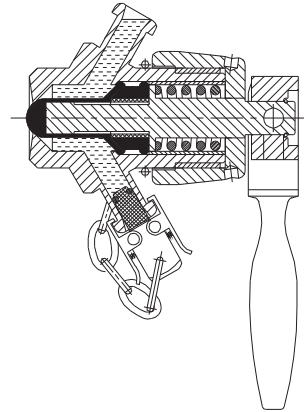

2. Remove the clip-on cap and drain the valve.

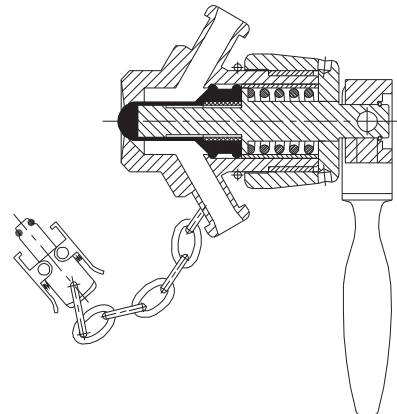

3. Close the upper outlet with the clip-on cap.

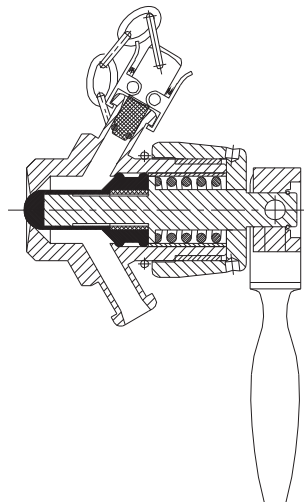

The instruction manual is part of delivery. Study the instructions carefully.
The items refer to the Parts List and Service Kits section.

4.3 Sterilisation with steam

Step 1

Always sterilise the valve before taking a sample.
Make sure that the valve is in the closed position before sterilisation.

Step 2

Sterilisation procedure:

1. Remove the clip-on cap from the valve lower connection.
2. Sterilise the valve for approximately 40 seconds using steam, added through a hose connected to the valve top connection.
3. Remove the steam hose.
4. Sterilise the clip-on cap with alcohol.
5. Close the upper connection with the clip-on cap.

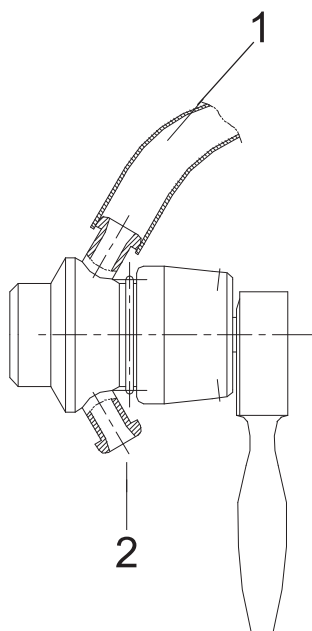

Pos. 1 Steam inlet
Pos. 2 Water/steam outlet



Heat accumulated during steaming will completely dry out the interior of the valve.

4 Operation

The instruction manual is part of delivery. Study the instructions carefully.
The items refer to the Parts List and Service Kits section.

4.4 Sampling

Step 1

Always sterilise the valve before taking a sample.
Sterilisation procedure:

1. Open/activate the valve to carry out sampling. For pneumatic valves, apply compressed air.

Pos. 1 Open

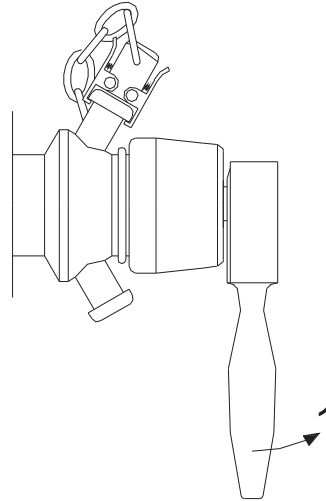

2. Carry out the sampling.

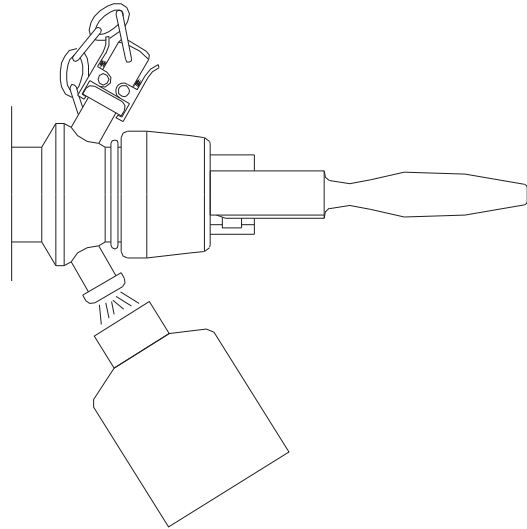

3. Close/deactivate the valve after sampling. For pneumatic valves, release the compressed air.

Pos 1 Close

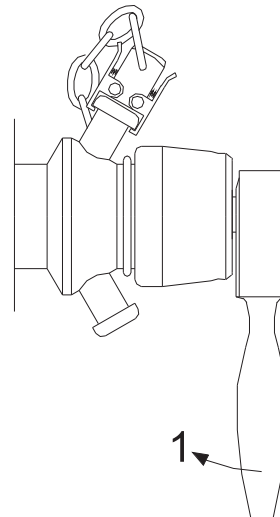

The instruction manual is part of delivery. Study the instructions carefully.
The items refer to the Parts List and Service Kits section.

Step 2

1. Remove the clip-on cap and rinse with water or alcohol.

Pos. 1 Use syringe

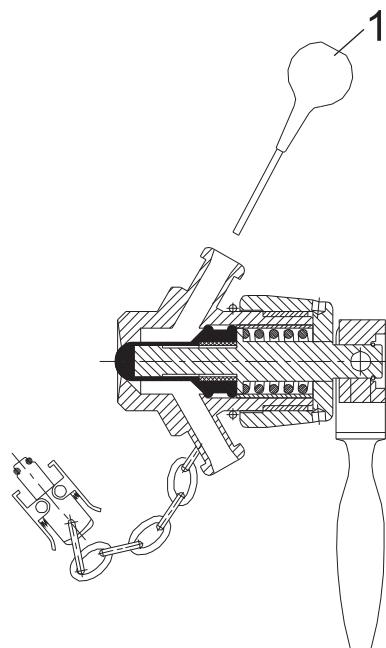

2. Put the clip-on cap on the lower connection and fill the valve with alcohol.

Pos. 1 Use syringe

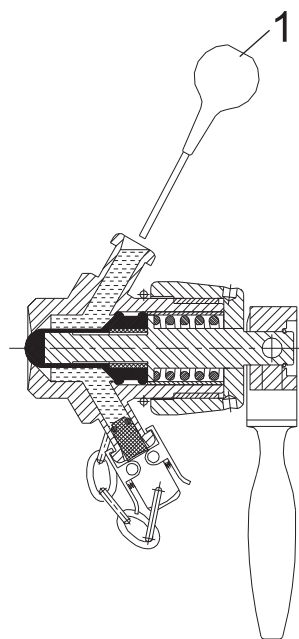

The valve is now sealed and has to be drained before the next sampling

5 Maintenance

Maintain the valve regularly.

Study the instructions carefully and pay special attention to the warnings!

Always keep spare rubber membranes in stock.

Check the valve for smooth operation after service.

5.1 General maintenance

Step 1



Always read the technical data thoroughly.
See chapter 6 Technical Data.



All scrap must be stored/disposed of in accordance with current regulations.



Always release compressed air after use.

Step 2



Never service the valve when it is hot.

Atmospheric pressure required!



Never service the valve with the valve and pipelines under pressure.

Burning hazard!



Step 3



Never touch the moving parts if the actuator is supplied with compressed air.

Moving parts!



Maintain the valve regularly.

Study the instructions carefully and pay special attention to the warnings!

Always keep spare rubber membranes in stock.

Check the valve for smooth operation after service.

Membrane maintenance

Regularly inspect the valves for leaks. Replace a leaking membrane within a few hours.

In general, it is recommended that the membrane is replaced every two months.

Replacement intervals for the membranes depend on frequency of sampling, cleaning procedure, temperature etc. It is recommended to monitor replacements in order to carry out planned maintenance. The membranes can be supplied in three different colours to facilitate the monitoring of replacements.

Step 1

The valve has to be in the open position before disassembly or the membrane may be damaged.

Step 2

Loosen the valve head and replace the membrane.

Step 3

Reassemble the valve in reverse order, observing that it has to be in the open position when mounting the valve head.

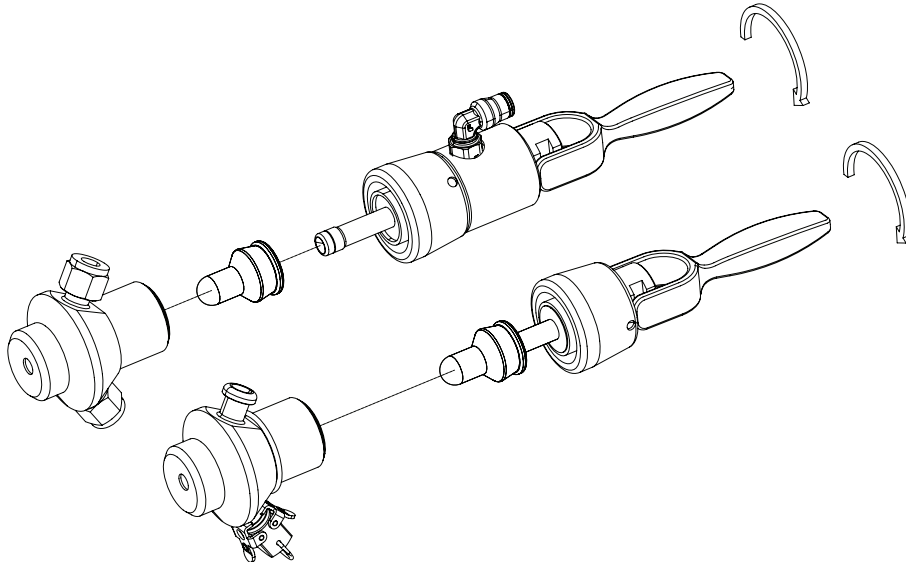

5 Maintenance

Maintain the valve regularly.

Study the instructions carefully and pay special attention to the warnings!

Always keep spare rubber membranes in stock.

Check the valve for smooth operation after service.

Actuator maintenance (Pneumatic version)

Replace O-rings, clean and lubricate the actuator every 5 years (depending on working conditions).

Step 1

- Remove locking ring (pos. 1).
- Remove activating ring (pos. 2).
- Loosen the end cover using two pins inserted in the two holes (pos. 3).
- Remove locking ring (pos. 4).
- Push the piston out of cylinder (pos. 5).
- Remove cylinder (pos. 6).

Step 2

- Replace and lubricate O-rings (pos. 7).
- Lubricate inner surface of cylinder (pos. 6).

Step 3

- Reassemble the valve in reverse order.
- Make sure to replace locking rings (pos. 1 & 4).
- Reassemble the valve in reverse order.

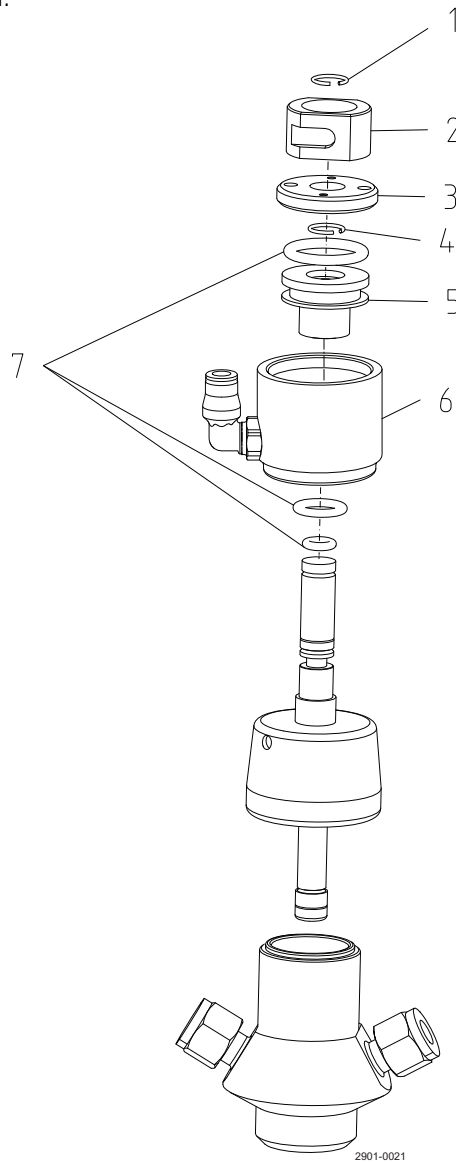

2901-0021

*It is important to observe the technical data during installation, operation and maintenance.
All personnel should be informed about the technical data.*

6.1 Technical data

The Membrane Sample Valve is used for sampling under sterile conditions for physico-chemical or microbiological analysis. When the valve is closed, the channel between the valve ports is open for sterilisation. When the valve is activated, the membrane is retracted allowing liquid to pass.

Valve data

Valve data	
Temperature range	1°C - 110°C
Product pressure	10 bar
Weight	0.86 kg
Materials	
Product wetted steel parts	EN 1.4404 (AISI 316L) with 3.1 cert.
Product wetted steel surfaces	Surface roughness Ra<0.8 µm (<32 µ")
Product wetted seals	EPDM
Membrane seal	EPDM, Silicone

Actuator data

Actuator for force opening	
Max. air supply	8 bar (116 psi)
Min. air supply	6 bar (87 psi)
Noise	70 dB(A)

7 Parts List and Service Kits

*It is important to observe the technical data during installation, operation and maintenance.
All personnel should be informed about the technical data.*

7.1 Membrane Sample Valve, manual

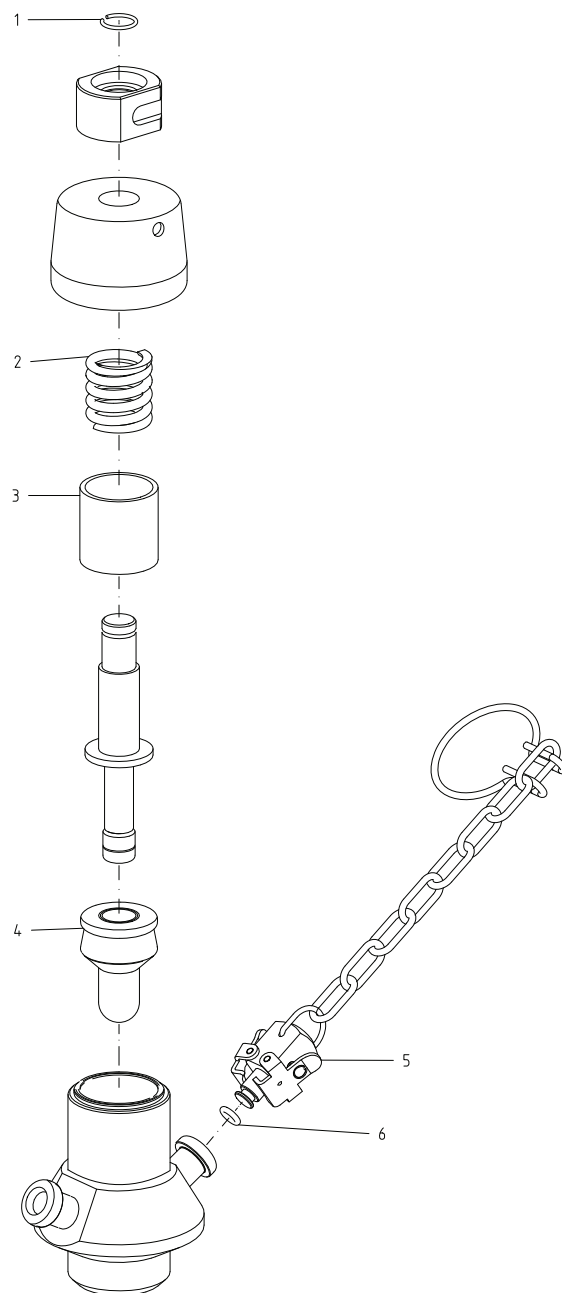

7 Parts List and Service Kits

*It is important to observe the technical data during installation, operation and maintenance.
All personnel should be informed about the technical data.*

Parts list

Pos.	Qty	Denomination
1	1	Locking ring
2	1	Spring
3	1	Bushing for spring
4	1	Membrane
5	1	Clip-on closing cap with chain (includes O-ring, pos 6)
6	1	O-ring

7 Parts List and Service Kits

*It is important to observe the technical data during installation, operation and maintenance.
All personnel should be informed about the technical data.*

7.2 Membrane Sample Valve, manual & micro port

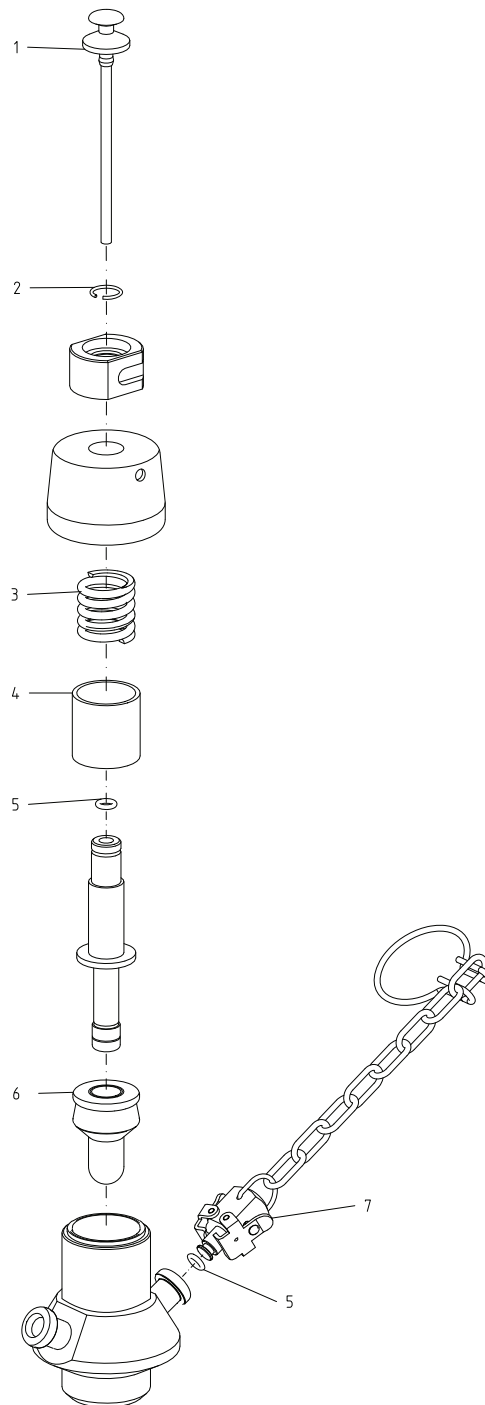

7 Parts List and Service Kits

*It is important to observe the technical data during installation, operation and maintenance.
All personnel should be informed about the technical data.*

Parts list

Pos.	Qty	Denomination
1	1	Closing cap w. pipe
2	1	Locking ring
3	1	Spring
4	1	Bushing for spring
5	1	O-ring, EPDM
6	1	Membrane, EPDM 20 pcs
	1	Membrane, Q 20 pcs
7	1	Clip-on closing cap with chain (includes O-ring)

7 Parts List and Service Kits

*It is important to observe the technical data during installation, operation and maintenance.
All personnel should be informed about the technical data.*

7.3 Membrane Sample Valve, pneumatic

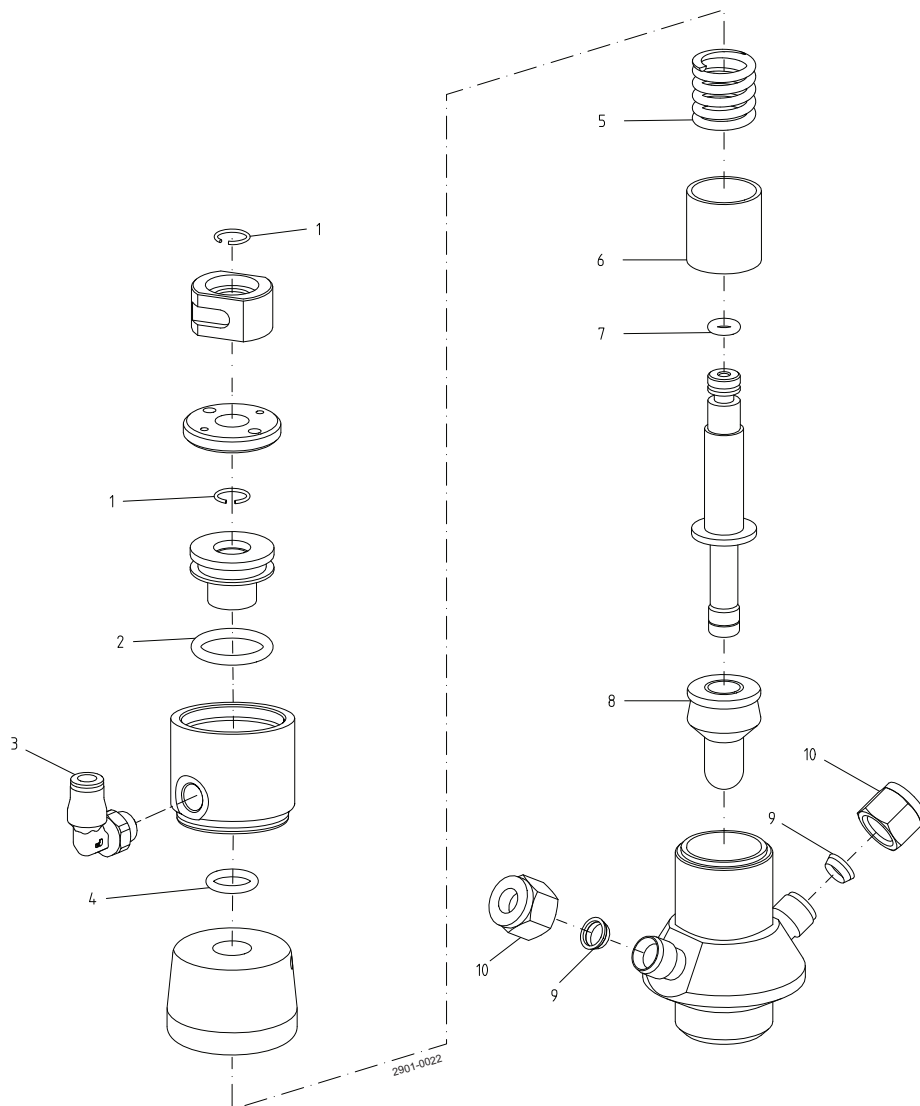

7 Parts List and Service Kits

*It is important to observe the technical data during installation, operation and maintenance.
All personnel should be informed about the technical data.*

Parts list

Pos.		Qty	Denomination
1	<input type="checkbox"/>	2	Locking ring
2	<input type="checkbox"/>	1	O-ring, NBR
3		1	Air inlet
4	<input type="checkbox"/>	1	O-ring NBR
5		1	Spring
6		1	Bushing for spring
7	<input type="checkbox"/>	1	O-ring, NBR
8		1	Membrane
9		2	Ferrule set
10		2	Nut

Service kits

Denomination

Service Kit 9611924317

Parts marked with are included in the service kits.

How to contact Alfa Laval

Contact details for all countries are continually updated on our website.

Please visit www.alfalaval.com to access the information directly.

© Alfa Laval Corporate AB

This document and its contents is owned by Alfa Laval Corporate AB and protected by laws governing intellectual property and thereto related rights. It is the responsibility of the user of this document to comply with all applicable intellectual property laws. Without limiting any rights related to this document, no part of this document may be copied, reproduced or transmitted in any form or by any means (electronic, mechanical, photocopying, recording, or otherwise), or for any purpose, without the expressed permission of Alfa Laval Corporate AB. Alfa Laval Corporate AB will enforce its rights related to this document to the fullest extent of the law, including the seeking of criminal prosecution.