



Alfa Laval ThinkTop® Digital

Match any level of valve control for fluid handling in hygienic applications

Introduction

The Alfa Laval ThinkTop® Digital is a modular valve control unit that offers reliable, cost-effective operation and standard functionality for automated sensing and control of hygienic valves. ThinkTop Digital provides real-time information about valve operating status 24/7 while boosting productivity and securing traceability.

Application

The ThinkTop Digital is designed to control the fluid handling process in hygienic applications across the dairy, food, beverage, biotechnology, pharmaceutical and many other industries.

Benefits

- Reliable and accurate valve sensing and control
- Proven and inherently safe design
- Low total cost of ownership
- Watertight design
- Easy to operate

Standard design

The ThinkTop Digital valve sensing and control unit consists of a proven no-touch, set-and-forget sensor system with light-emitting diodes (LEDs), solenoid valves, and valve control sensor board for connection to any programmable logic controller (PLC) system with a digital interface. It fits on all Alfa Laval hygienic valves; no adapter is required.

Installation is straightforward. No special expertise or tools are required. To initiate manual setup, simply press a push-button startup sequence. Or set up without dismantling the control unit using the optional infrared (IR) keypad for remote control.

Working principle

The sensor system accurately detects valve stem movement, the position of the valve at any given time, with an accuracy of $\pm 0.1\text{mm}$ through the use of microchip sensors. To locate the current valve position, sensor chips inside the sensor board calculate the angle between the axial magnetic field produced by an indication pin mounted on the valve stem.



The solenoid valves receive signals from the PLC system to activate or deactivate the air-operated valve. It then transmits feedback signals indicating the main valve position and condition back to the PLC system.

In the control unit, up to three electric solenoid valves can physically convert compressed air into mechanical energy to activate or deactivate the pneumatic valve actuator.

Each control unit fits any Alfa Laval hygienic valve and provides a tolerance band for valves to prevent product contamination and failure. This eliminates the need to readjust the sensors and boosts productivity.

LEDs conveniently display all the valve positions, solenoid activation, setup and local fault indication on the control unit.

Certificates



TECHNICAL DATA

Communication	
Interface:	Digital PNP/NPN
Supply voltage:	24 ± 10% VDC

Sensor board	
Max current consumption:	45mA
Feedback signal #1:	Closed valve
Feedback signal #2:	Open valve
Feedback signal #3:	Seat-lift 1
Feedback signal #4:	Seat-lift 2
Feedback signal #5:	Status
Valve tolerance band options:	5
Default tolerance band:	± 5 mm
Sensor accuracy:	± 0.1 mm
Stroke length:	0.1 - 80 mm

Solenoid valve	
Max current consumption:	45mA
Air supply:	300-900 kPa (3-9 bar)
Type of solenoids:	3/2-ways or 5/2-ways
Numbers of solenoids:	0-3
Manual hold override:	Yes
Throttle, Air in/out 1A, 1B:	0-100 %
Push-in fittings:	ø6 mm or 1/4"

PHYSICAL DATA

Materials	
Steel parts:	Stainless steel and Brass
Plastic parts:	Blue Nylon PA 12
Seals:	Nitrile (NBR) rubber

Environment	
Working temperature:	-20 °C to +85 °C
Protection class:	IP66 and IP67
Protection class equivalent:	NEMA 4.4x and 6P

Cable connection	
Main cable gland:	PG11 (4-10 mm)
Max wire size:	0.75 mm ² (AWG 19)
Optional cable gland:	PG7 (4 - 6.8 mm)

Note!

For further information: See also ESE00353

The ThinkTop has Patented Sensor System, Registered Design and Registered Trademark owned by Alfa Laval

Options

- Solenoid valve configuration
- Pneumatic tubing interface

Accessories

- Remote programming (IR keypad)
- For upper seat-lift detection on Mixproof valves:
 - External PNP sensors (Refer to Brackets and Inductive Sensors)
 - Cable gland PG7
 - External sensor bracket (Refer to Brackets and Inductive Sensors)
- Various cable options
- Threaded plate for indication pin on SRC, SMP-BC and i-SSV valves
- Special indication pin for Unique SSV-LS, Unique SSV High Pressure valves
- Adaptor for Unique SSSV valves

Dimensions (mm)

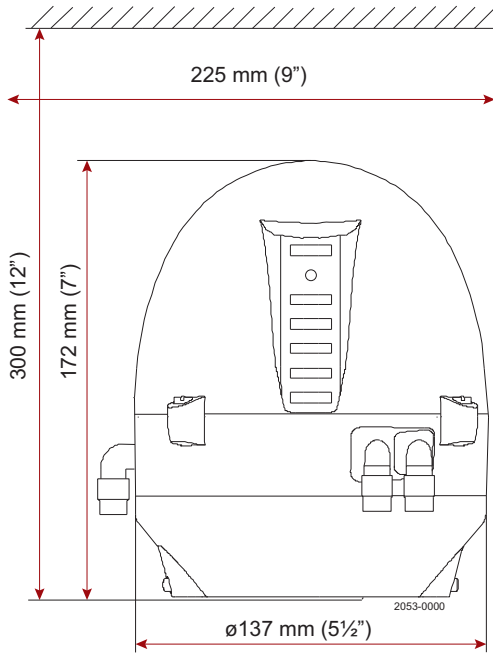

Electrical connection

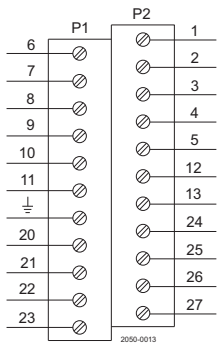

6	Solenoid 1	1	Closed valve
7	Solenoid 2	2	Open valve
8	Solenoid 3	3	Seat-lift 1
9	Supply +	4	Seat-lift 2
10	Supply -	5	Status
11	Solenoid com	12	NPN/PNP Jumper
Earth	Earth	13	NPN/PNP Jumper
20	Solenoid common grey	24	Seat-lift 1 "upper"
21	Solenoid 1, grey	25	Seat-lift 2 "lower"
22	Solenoid 2, grey	26	Supply +
23	Solenoid 3, grey	27	Supply -

Alfa Laval reserves the right to change specifications without prior notification.

How to contact Alfa Laval

Contact details for all countries
are continually updated on our website.
Please visit www.alfalaval.com to
access the information direct.

www.sks-online.com