



KIESELMANN
FLUID PROCESS GROUP

Translation of the original

Operating instruction

Non return valve Type: 5091



spring loaded



PDF • ak • 16/01/2019

KIESELMANN GmbH

Paul-Kieselmann-Str. 4-10
75438 Knittlingen

 +49(0) 7043 371-0 •  +49(0) 7043 371-125
www.kieselmann.de • info@kieselmann.de

Copyright: © KIESELMANN FLUID PROCESS GROUP

Table of contents

1	General informations	4
1.1	Informations for your safety	4
1.2	Marking of security instructions	4
1.3	General designated use	4
1.4	Personnel	5
1.5	Modifications, spare parts, accessories	5
1.6	General instructions	5
2	Safety instructions.....	6
2.1	Intended use	6
2.2	General notes.....	6
2.3	General safety instructions.....	6
3	Delivery, transport and storage	7
3.1	Delivery.....	7
3.2	Transport.....	7
3.3	Storage.....	7
4	Specification.....	8
4.1	Valve types.....	8
5	Function and operation	9
5.1	Description of function.....	9
5.2	Commissioning, service and maintenance.....	9
5.2.1	Commissioning.....	9
5.2.2	Service.....	10
5.2.3	Cleaning	10
6	Technical data	11
6.1	Check valves Type 5091	11
7	Disassembly and assembly	12
7.1	Disassembly.....	12
7.2	Assembly	13
8	Drawings and dimensions	14
8.1	Drawings	14
8.2	Dimensions	15
9	Wearing parts	16
9.1	Wear parts kit.....	16

1 General informations

1.1 Informations for your safety

We are pleased that you have decided for a high-class KIESELMANN product. With correct application and adequate maintenance, our products provide long time and reliable operation.





Before installation and initiation, please carefully read this instruction manual and the security advices contained in it. This guarantees reliable and safe operation of this product and your plant respectively. Please note that an incorrect application of the process components may lead to great material damages and personal injury.

In case of damages caused by non observance of this instruction manual, incorrect initiation, handling or external interference, guarantee and warranty will lapse!

Our products are produced, mounted and tested with high diligence. However, if there is still a reason for complaint, we will naturally try to give you entire satisfaction within the scope of our warranty. We will be at your disposal also after expiration of the warranty. In addition, you will also find all necessary instructions and spare part data for maintenance in this instruction manual. If you don't want to carry out the maintenance by yourself, our KIESELMANN - service team will naturally be at your disposal.

1.2 Marking of security instructions

Hints are available in the chapter "safety instructions" or directly before the respective operation instruction. The hints are highlighted with a danger symbol and a signal word. Texts beside these symbols have to be read and adhered to by all means. Please continue with the text and with the handling at the valve only afterwards.

Symbol	Signal word	Meaning
	DANGER	Imminent danger which will result severe personal injury or death.
	WARNING	Imminent danger which may result severe personal injury or death.
	CAUTION	Dangerous situation which may cause slight personal injury or material damages.
	NOTICE	An harmful situation which may result in damages of the product itself or of adjacent vicinity.
	INFORMATION	Marks application hints and other information which is particularly useful.

1.3 General designated use

The fitting is designed exclusively for the purposes described below. Using the fitting for purposes other than those mentioned is considered contrary to its designated use. KIESELMANN cannot be held liable for any damage resulting from such use. The risk of such misuse lies entirely with the user. The prerequisite for the reliable and safe operation of the fitting is proper transportation and storage as well as competent installation and assembly. Operating the fitting within the limits of its designated use also involves observing the operating, inspection and maintenance instructions.

1.4 Personnel

Personnel entrusted with the operation and maintenance of the tank safety system must have the suitable qualification to carry out their tasks. They must be informed about possible dangers and must understand and observe the safety instructions given in the relevant manual. Only allow qualified personnel to make electrical connections.

1.5 Modifications, spare parts, accessories

Unauthorized modifications, additions or conversions which affect the safety of the fitting are not permitted. Safety devices must not be bypassed, removed or made inactive. Only use original spare parts and accessories recommended by the manufacturer.

1.6 General instructions

The user is obliged to operate the fitting only when it is in good working order. In addition to the instructions given in the operating manual, please observe the relevant accident prevention regulations, generally accepted safety regulations, regulations effective in the country of installation, working and safety instructions effective in the user's plant.

2 Safety instructions

2.1 Intended use

This type of non-return valve is used as an independent non-return stop valve for liquid and gas media in systems used in the food and drinks industry, the pharmaceutical industry and the biotechnology industry.

2.2 General notes



NOTICE - observe the operating instructions

To avoid danger and damage, the fitting must be used in accordance with the safety instructions and technical data contained in the operating instructions.



NOTICE

All data are in line with the current state of development. Subject to change as a result of technical progress.

2.3 General safety instructions



⚠ WARNING

Risk of injury by outflowing medium

Dismantling the valve or valve assemblies from the plant can cause injuries.

- a) Media flowing through the leakage drain outlet are to be drained off without splashing into a discharge arrangement.
- b) Carry the disassembling only if when the plant has been rendered pressure-less and free of liquid and gas.



⚠ WARNING

ATEX - Guidelines

If the valve or the plant is operated in a potentially explosive atmosphere, the valid ATEX directive of the EC and the installation instructions in this operating manual must be observed.



⚠ CAUTION

Before starting the system, the entire pipeline system must be thoroughly cleaned.



⚠ CAUTION

Steps should be taken to ensure that no external forces are exerted on the fitting.

3 Delivery, transport and storage

3.1 Delivery

Immediately after receipt check the delivery for completeness and transport damages.

Remove the packaging from the product.

Retain packaging material, or expose of according to local regulations.

3.2 Transport



CAUTION

Risk of injury and damage to the product

During the transport the generally acknowledged rules of technology, the national accident prevention regulations and company internal work and safety regulations must be observed.

3.3 Storage



NOTICE

Damage to the product due to improper storage!

Observe storage instructions

avoid a prolonged storage



INFORMATION

Recommendation for longer storage

We recommend regularly checking the product and the prevailing storage conditions during long storage times.

- To avoid damage to seals and bearings,
 - products up to DN 125 / OD 5 inch should be stored horizontally for maximum 6 months.
 - products larger than DN 125 / 5 inch, should be stored in the upright position with the actuator on top.
- Don't store any objects on the products.
- Protect the products for wetness, dust and dirt.
- The product should be stored in a dry and well ventilated room at a constant temperature (optimal indoor temperature: 25 C ±5 ; indoor humidity data 70% ±5%).
- Protect seals, bearings and plastic parts for UV light and ozone.

4 Specification

4.1 Valve types

check valve O-ring - design

Couplings with connections

- S-K/M = welded end- taper nut
- G-K/M = male - taper nut
- K/M-K/M = taper nut - taper nut
- Cl-K/M = clamp- taper nut

Valve housings with connections

- G-S = male - welded coupling
- G-G = male - male
- G-K/M = male - taper nut
- G-Cl = male - clamp

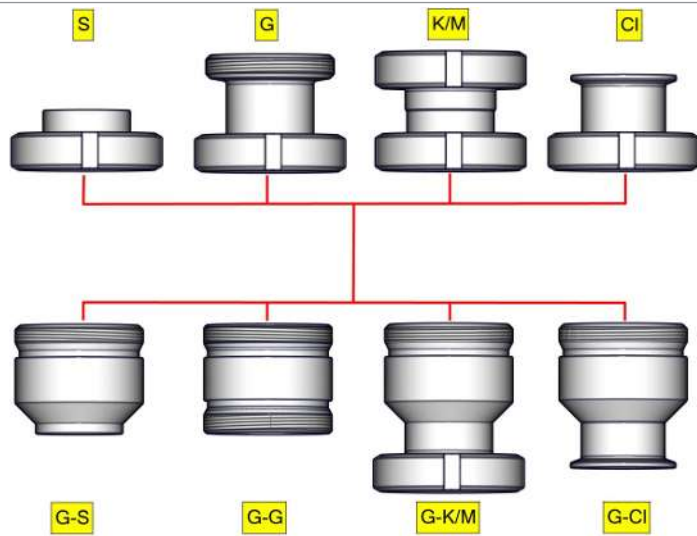

Valve size		seals			
DN	Inch	EPDM	HNBR	FKM	Silicone
010 = DN 10	-	x	x	-	-
015 = DN 15	-	x	x	-	x
020 = DN 20	-	x	x	-	-
025 = DN 25	026 = OD 1"	x	x	x	-
032 = DN 32	-	x	x	x	-
040 = DN 40	038 = OD 1 1/2"	x	x	x	x
050 = DN 50	051 = OD 2"	x	x	x	x
065 = DN 65	064 = OD 2 1/2"	x	x	x	-
080 = DN 80	076 = OD 3"	x	x	x	-
100 = DN 100	101 = OD 4"	x	x	x	-

DN = nominal diameter = z.B. 5091 050 000-041

OD = outside diameter= z.B. 5091 051 000-041

5 Function and operation

5.1 Description of function

The valve open against spring power with flow pressure > X bar in flow direction "A" (see Tab.). The valve close added by spring power with flow pressure > 0,1 bar in flow direction "B".

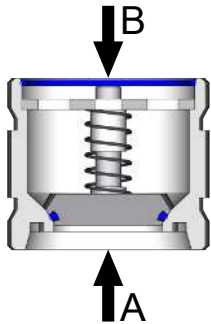

DIN Inch	Nominal diameter DN / OD										
	10	15	20	25	32	40	50	65	80	100	
Flow pressure: ¹	0.50	0.40	0.20	0.11	0.09	0.14	0.15	0.16	0.15	0.07	

1. measured in installation position and flow direction from bottom to top



NOTICE

A pressure from minimum 0,8 bar is necessary for a leakproof shut off in flow direction "B".

5.2 Commissioning, service and maintenance

5.2.1 Commissioning

5.2.1.1 Installation instructions

Fitting position

Unidirectional disc valves are preferably fitted vertically, with a flow from bottom to top.

Other installations are possible, but the fitting's function must be thoroughly checked in operation.



NOTICE

The flow should generally run along the direction of arrow A.

With horizontal installation, a small amount of fluid remains in the sphere in the casing.

5.2.1.2 General welding guidelines

Sealing elements integrated in weld components must generally be removed prior to welding. To prevent damage, welding should be undertaken by certified personnel (EN ISO 9606-1). Use the TIG (Tungsten Inert Gas) welding process.



CAUTION

Damage and injuries due to high temperature supply

To avoid a distortion of the components, all welding parts must be welded to stress-relieved. Allow all components to cool before assembling.



NOTICE

Damage due to impurities

Impurities can cause damage to the seals and seals area.
Clean inside areas prior to assembly.

5.2.1.3 ATEX - Guidelines

For valves or plants/installations that are operated in the ATEX area, sufficient bonding (grounding) must be ensured (see valid ATEX Guidelines EG).

5.2.2 Service

Maintenance interval

The maintenance intervals depend on the operating conditions "temperature, temperature-intervals, medium, cleaning medium, pressure and opening frequency". We recommend replacing the seals 1-year cycle. The user, however should establish appropriate maintenance intervals according to the condition of the seals.



RECOMMENDATION

Replacement of seals

To achieve optimal maintenance cycles, the following points must be observed!

- a) When replacement of seals, all product-contacting seals should be replaced.
- b) Only original spare parts may be installed.

Lubricant recommendation

	EPDM; HNBR; NBR; FKM; k-flex	-	Klüber Paraliq GTE703*
	Silicone	-	Klüber Sintheso pro AA2*
	Thread	-	Interflon Food*
	*) It is only permitted to use approved lubricants, if the respective fitting is used for the production of food or drink. Please observe the relevant safety data sheets of the manufacturers of lubricants.		

Lubricant recommendation

	EPDM; HNBR; NBR; FKM; k-flex	-	Klüber Paraliq GTE703*
	Silicone	-	Klüber Sintheso pro AA2*
	Thread	-	Interflon Food*
	*) It is only permitted to use approved lubricants, if the respective fitting is used for the production of food or drink. Please observe the relevant safety data sheets of the manufacturers of lubricants.		

5.2.3 Cleaning

Cleaning

Ideally, cleaning is carried out with duct cleaning when the valve is open.

6 Technical data



6.1 Check valves Type 5091

Model:	check valve Design: Sealing = O-ring	
Valve size:	DIN: DN10 - DN100 Inch: OD1 - OD4	
Connections:	Welded end (S) DIN EN 10357 Male (G) DIN 11851 Liner/nut (K/M) DIN 11851 Clamp (Cl)	
Temperature range:	Ambient temperature: Operating temperature: Sterilization temperature:	+4 to +45°C (air) +0 to +95°C (medium dependent) EPDM +140°C (SIP 30 min) HNBR +110°C (SIP 30 min) FKM +95°C (SIP 30 min) Silicone +110°C (SIP 30 min)
Operating pressures:	10 bar	
Leak rate:	A (DIN EN 12266-1)	
Materials: (in product contact)	Stainless steel:	1.4301 / AISI304 1.4404 / AISI316L
	Surfaces:	Ra < 0,8µm e-polished
	Sealing material:	EPDM (FDA) HNBR (FDA) FKM (FDA) Silicone (FDA)

	DN / OD									
DIN	10	15	20	25	32	40	50	65	80	100
Inch	-	-	-	1	-	1½	2	2½	3	4
KV-value (m³/h):	1	3.5	4.5	18	28.5	36	60	104	150	230

7 Disassembly and assembly

7.1 Disassembly

T11		Hinged hook wrench	-	8027000065-000
T30		Needle	-	-



NOTICE

All screw connections have right-handed threads.

Disassembly

- Unscrew the nuts (N) on both sides and remove the valve from the pipe system.
- Dismount the inner parts from housing (VG).
- Remove O-ring (D1).



NOTICE

a) Puncture the O-ring with a needle and remove them carefully from the groove of piston.

- Remove O-ring (D2) and (D3).

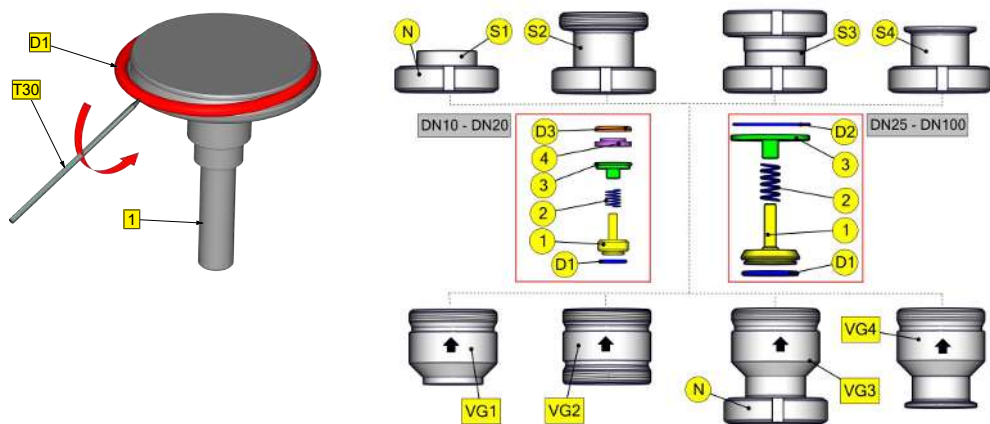

1	Plate	S1	Socket S-K/M
2	Spring	S2	Socket G - K/M
3	guidance	S3	Socket K/M - K/M
4	Adapter (DN10-DN20)	S4	Socket Cl - K/M
D1	O-ring	VG1	Housing G-S
D2	O-ring	VG2	Housing G-G
D3	Seal (DN10-DN20)	VG3	Housing G-K/M
N	Slotted nut	VG4	Housing G-Cl

S = welded end; G = male; K/M = cone/nut; Cl = clamp

7.2 Assembly



INFORMATION

- a) For the installation and removal is axially a minimum space requirement necessary (measure X).
- b) Alternately press and roll the O-ring (D1) into the groove with round body.

- Before installation, thoroughly clean and slightly lubricate mounting areas and running surfaces.
- Assemble in reverse order.



NOTICE

Alternately press and roll the O-ring into the groove with round body.

Performance test

- Check the function according to the specified performance data in the operating state.

8 Drawings and dimensions

8.1 Drawings

DN10 - DN20

- 1 = Plate
- 2 = Spring
- 3 = Guidance
- 4 = Receiver

- D1 = O-ring
- D2 = -
- D3 = Seal
- VG2 = Housing

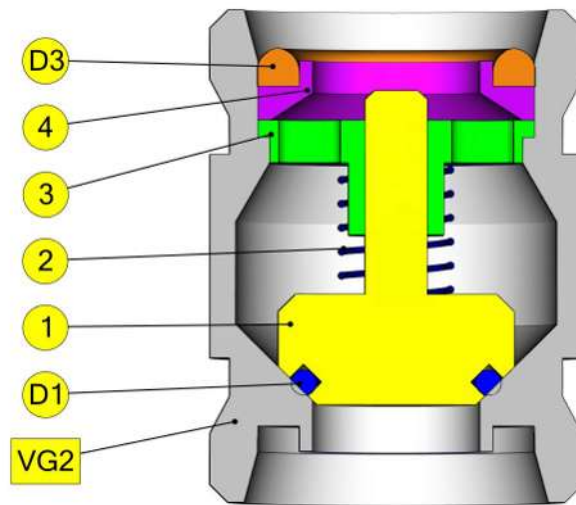

DN25 - DN100

- 1 = Plate
- 2 = Spring
- 3 = Guidance

- D1 = O-ring
- D2 = O-ring

- VG2 = Housing

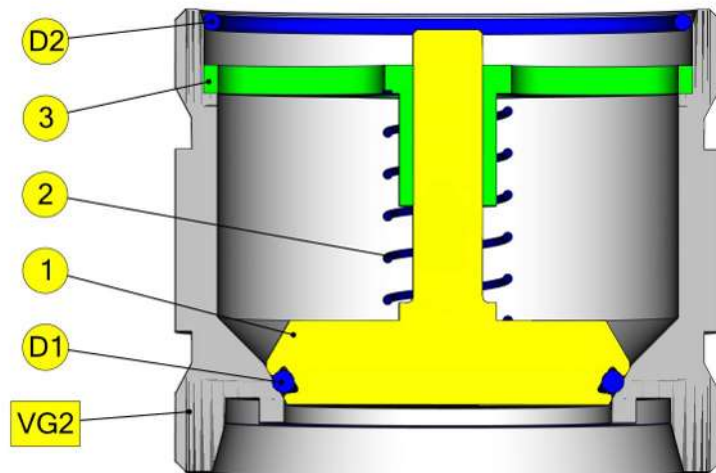

8.2 Dimensions

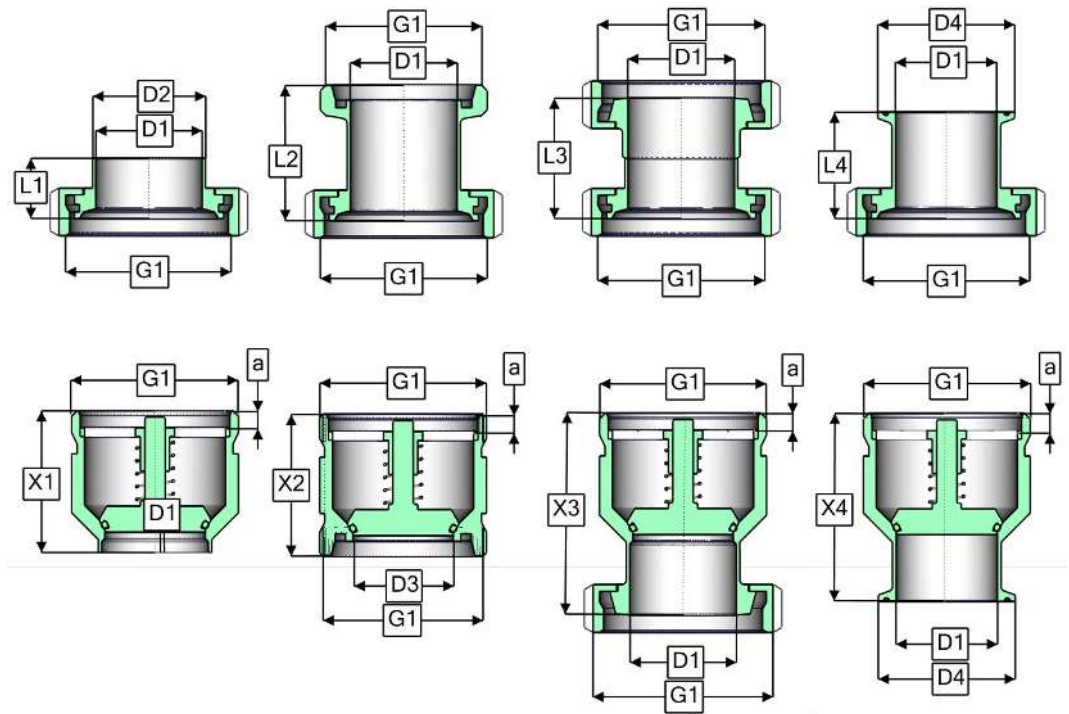

DN	D1	D2	D3	D4	G1	L1	L2	L3	L4	X1	X2	X3	X4	a
10	10	13	10	34	Rd28x1/8	17	38	34	42	41	45	58	59	4
15	16	19	16	34	Rd34x1/8	17	38	34	42	49	50	66	70	4
20	20	23	20	34	Rd44x1/6	18	42	36	43	52	58	70	69.5	6
25	26	29	25.5	50.5	Rd52x1/6	22	51	44	43.5	48	50	70	69.5	7
32	32	35	30	50.5	Rd58x1/6	25	57	50	46.5	50	51	75	71.5	7
40	38	41	36	50.5	Rd65x1/6	26	59	52	47.5	58	59	84	79.5	7
50	50	53	47	64	Rd78x1/6	28	63	56	49.5	66	66	94	87.5	8
65	66	70	64	91	Rd95x1/6	40	80	72	68	73	75	105	104	12
80	81	85	77	106	Rd110x1/4	45	90	82	72	87	88	124	115	15
100	100	104	100	119	Rd130x1/4	50	104	94	78	107	117	151	135	9

OD	D1	D2	D3	D4	G1	L1	L2	L3	L4	X1	X2	X3	X4	a
1"	22.1	25.4	22.1	50.5	Rd52x1/6	20	-	-	-	49	52	-	70.5	7
1½"	34.8	38.1	34.8	50.5	Rd65x1/6	26	-	-	47.5	58	59	-	79.5	7
2"	47.5	50.8	47.5	64	Rd78x1/6	28	-	-	49.5	66	66	-	87.5	8
2½"	60.2	63.5	60.2	77.5	Rd95x1/6	40	-	-	68	-	78	-	101	12
3"	72.1	76.1	72.1	91	Rd110x1/4	45	-	-	-	-	92	-	-	15
4"	97.6	101.6	97.6	119	Rd130x1/4	50	-	-	-	-	117	-	-	9

9 Wearing parts

9.1 Wear parts kit

Wear parts set EPDM O-Ring-design

DN	Set- EPDM	Pos. D1	Pos. D2 / D3	Pos. 2
DIN / Inch	include positions D1, D2 respectively. 2, D3	O-ring (plate)	D3 Dichtring (DN10-DN20) D2 O-Ring (DN25-DN100)	Spring
10 / -	5099 010 000-060	2304 009 025-170	2004 010 000-054	8150 115 030-031
15 / -	5099 015 000-060	2304 012 030-170	2004 015 000-054	8150 117 070-031
20 / -	5099 020 000-060	2304 014 030-170	2004 020 000-054	8150 117 070-031
25 / 1	5099 025 029-054	2304 020 030-170	2304 035 030-170	8150 117 060-031
32 / -	5099 032 029-054	2304 024 035-170	2304 042 030-170	8150 117 060-031
40 / 1½	5099 040 029-054	2304 028 035-170	2304 046 030-170	8150 181 000-031
50 / 2	5099 050 029-054	2304 041 035-170	2304 060 030-170	8150 182 000-031
65 / 2½	5099 065 029-054	2304 057 035-170	2304 085 035-159	8150 209 000-031
80 / 3	5099 080 029-054	2304 069 035-170	2304 100 040-159	8150 236 000-031
100 / 4	5099 100 029-054	2304 088 035-170	2304 117 035-159	8150 236 000-031

Wear parts set HNBR O-ring - design

DN	Set- HNBR	Pos. D1	Pos. D2 / D3	Pos. 2
DIN / Inch	include positions D1, D2 respectively. 2, D3	O-ring (plate)	D3 Dichtring (DN10-DN20) D2 O-Ring (DN25-DN100)	Spring
10 / -	5099 010 000-050	2304 009 025-055	2004 010 000-050	8150 115 030-031
15 / -	5099 015 000-050	2304 012 030-055	2004 015 000-050	8150 117 070-031
20 / -	5099 020 000-050	2304 014 030-050	2004 020 000-050	8150 117 070-031
25 / 1	5099 025 029-050	2304 020 030-050	2304 035 030-050	8150 117 060-031
32 / -	5099 032 029-050	2304 024 035-050	2304 041 035-050	8150 117 060-031
40 / 1½	5099 040 029-050	2304 028 035-050	2304 047 025-157	8150 181 000-031
50 / 2	5099 050 029-050	2304 041 035-050	2304 060 030-050	8150 182 000-031
65 / 2½	5099 065 029-050	2304 057 035-050	2304 085 035-050	8150 209 000-031
80 / 3	5099 080 029-050	2304 069 035-050	2304 100 040-050	8150 236 000-031

DN	Set- HNBR	Pos. D1	Pos. D2 / D3	Pos. 2
DIN / Inch	include positions D1, D2 respectively. 2, D3	O-ring (plate)	D3 Dichtring (DN10-DN20) D2 O-Ring (DN25-DN100)	Spring
100 / 4	5099 100 029-050	2304 088 035-050	2304 118 054-050	8150 236 000-031

Wear parts set VITON O-ring - design

DN	Set- VITON	Pos. D1	Pos. D2	Pos. 2
DIN / Inch	include positions D1, D2, 2	O-ring (plate)	O-ring	Spring
10 / -	5099 010 000-051	2304 009 025-051	2008 010 000-051	8150 115 030-031
15 / -	5099 015 000-051	2304 012 030-051	2008 015 000-051	8150 117 070-031
20 / -	5099 020 000-051	2304 014 030-051	2004 020 000-051	8150 117 070-031
25 / 1	5099 025 029-051	2304 020 030-051	2304 035 030-051	8150 117 060-031
32 / -	5099 032 029-051	2304 024 035-051	2304 041 035-051	8150 117 060-031
40 / 1½	5099 040 029-051	2304 028 035-051	2304 047 035-178	8150 181 000-031
50 / 2	5099 050 029-051	2304 041 035-051	2304 062 030-051	8150 182 000-031
65 / 2½	5099 065 029-051	2304 057 035-051	2304 085 035-051	8150 209 000-031
80 / 3	5099 080 029-051	2304 069 035-051	2304 100 040-051	8150 236 000-031
100 / 4	5099 100 029-051	2304 088 035-051	2304 118 045-051	8150 236 000-031

Wear parts set SILICONE O-ring - design

DN	Set - SILICONE	Pos. D1	Pos. D2	Pos. 2
DIN / Inch	include positions D1, D2, 2	O-ring (plate)	O-ring	Spring
10 / -	-	-	-	-
15 / -	-	2304 012 030-052	2007 015 000-052	8150 117 070-031
20 / -	-	-	-	-
25 / 1	-	-	-	-
32 / -	-	-	-	-
40 / 1½	-	-	-	-
50 / 2	-	2304 041 035-052	2304 060 035-052	8150 182 000-031
65 / 2½	-	2304 054 035-052	2304 085 035-052	8150 209 000-031
80 / 3	-	-	-	-
100 / 4	-	-	-	-