



Alfa Laval LKH Evap

Centrifugal pumps

Introduction

The Alfa Laval LKH Evap Centrifugal Pump is a premium pump for use in hygienic applications. As a low-NPSHr, high-efficiency centrifugal pump, the LKH Evap is a tailored evaporator pump supported by strong and extensive documentation, including a comprehensive vacuum curve package. It features a special scraper impeller, ClearFlow, that solves the product buildup problem in high solids applications, which can prolong production time between cleaning.

Precision-engineered, the LKH Evap pump delivers greater energy efficiency than similar pumps. Its optimized design, premium motor, tight tolerances and advanced impeller design minimize recirculation and reduce energy consumption.

Applications

The LKH Evap Centrifugal Pump is designed for hygienic applications across the dairy, food, beverage, brewery, alcohol, ethanol, starch and chemical industries. It is ideal for use in evaporation duties for applications, such as liquid concentration and powder processing as well as plant and equipment dewatering.

The LKH Evap pump is available in 10 sizes to handle capacities up to 280 m³/h and differential pressures up to 11 bar at 50 Hz.

Benefits

- Energy efficient: superior efficiency resulting in reduced energy consumption and CO₂ footprint.
- Hygienic: designed according to the most stringent hygienic design standards and with verified and effective Cleaning-in-Place.
- Low NPSHr: reduced NPSHr enables optimized system designs.
- Maximized uptime and reduced maintenance costs: robust mechanical design and ease of maintenance with modular front-loading seals.

Standard design

All media contacting steel components like pump casing, impeller, impeller nut and backplate are in W. 1.4404 (AISI 316L). A stainless steel shroud protects the motor and four adjustable stainless steel legs support the complete unit.

A compression coupling securely attaches the stub shaft to the motor shaft with precision alignment, and the semi-open impeller with a special vane design ensures efficient and gentle handling of the product as it moves through the pump.

As standard, the LKH Evap pump is equipped with a single mechanical shaft seal but is also available with a single flushed or a double mechanical shaft seal. The front-loading shaft seal, with the spring and washers mounted on the atmospheric side, makes maintenance fast, easy and inexpensive. It takes just a few minutes to replace the shaft seal. In addition, the balanced design minimizes the risk of seal opening during unforeseen pressure shock.

LKH Evap is available with the Clear Flow Impeller which is to be used in applications where there is a risk of building up a hard layer of product between impeller and backplate.



TECHNICAL DATA

Materials

Product wetted steel parts:	W. 1.4404 (316L)
Other steel parts:	Stainless steel
Inside surface finish:	Standard blasted
Product wetted elastomers:	EPDM
Ratary seal face:	Carbon
Stationary seal face:	Silicon Carbide

Motor

Foot-flanged motor according to the IEC metric standard, 2 poles = 3000/3600 rpm at 50/60 Hz, 4 poles = 1500/1800 rpm at 50/60 Hz, IP 55 (with drain hole with labyrinth plug), insulation class F.

Motor sizes

50Hz:	1.5 - 75 kW
60Hz:	1.2 - 80 kW

Min/max motor speed

2 poles: 1.5 - 45 kW:	900 - 4000 rpm
2 poles: 55 - 75 kW:	900 - 3600 rpm
4 poles: 1.5 - 75 kW:	900 - 2200 rpm

Warranty

Extended 3-years warranty on LKH Evap pumps. The warranty covers all non wear parts on the condition that genuine Alfa Laval Spare Parts are used.

OPERATING DATA

Max inlet pressure

LKH Evap 10 - 70:	1000kPa (10 bar)
LKH Evap 70, 60Hz:	500kPa (5 bar)

Temperature

Temperature range:	-10°C to +140°C (EPDM)
Flush media:	Max 70°C

Flushed shaft seal

Water pressure inlet:	Max. 1 bar
Water consumption:	0.25 - 0.5 l/min

Double mechanical shaft seal

Water pressure inlet, LKH Evap 10 to 60:	Max. 500 kPa (5 bar)
Water pressure inlet, LKH Evap 70:	Max. 300 kPa (3 bar)
Water consumption:	0.25 - 0.5 l/min

Connections for flushed and double mechanical shaft seal

LKH Evap 10 - 70:	1/8" G
-------------------	--------

Dimensions (mm)

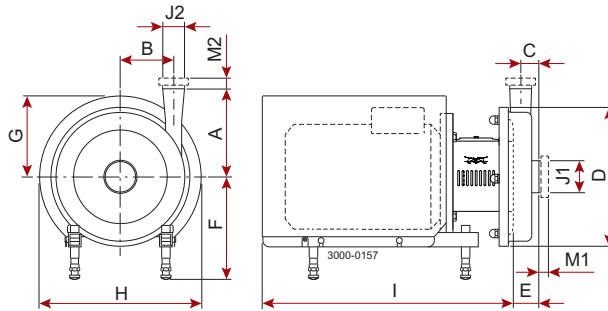

Pump specific measures

Pump Model	LKHevap-10	LKHevap-15	LKHevap-20	LKHevap-25	LKHevap-35	LKHevap-40	LKHevap-45	LKHevap-50	LKHevap-60	LKHevap-70
A	142	166	180	193	193	212	212	205	261	254
B	87	66	88	106	119	126	126	118	102	147
C	23	43	27	32	23	28	28	35	62	25
D	247	247	253	303	303	329	329	329	329	408
E	51	87	63	69	54	64	64	77	106	76

Motor specific measures

Motor IEC	IEC90	IEC100	IEC112	IEC132	IEC160	IEC180	IEC200	IEC250
Motor kW	1.5/2.2	3.0	4.0	5.5/7.5	11/15/18.5	22	30/37/45	55/75
F(max)*	262	282	285	304	332	352	372	446
G	157	185	198	196	262	286	399	394
H	288	325	359	383	485	533	670	738
I (LKHevap-10 to -60)	434	516	497	597	791	842	980	-
I (LKHevap-70)	-	-	-	-	804	855	993	1051

*Possible to reduce dimension F by min. 59 mm for all pump models. For smaller models it will be possible to reduce dimension F even further.

Motor overview

Pump Model	LKHevap-10	LKHevap-15	LKHevap-20	LKHevap-25	LKHevap-35	LKHevap-40	LKHevap-45	LKHevap-50	LKHevap-60	LKHevap-70
Motor range (IEC)	IEC90- IEC112	IEC100- IEC132	IEC90- IEC132	IEC132- IEC160	IEC112- IEC160	IEC132- IEC180	IEC112- IEC160	IEC132- IEC180	IEC132- IEC200	IEC132- IEC250

Dimensional data are based on 2 pole, ABB motors.

Connections

Pump Model	LKHevap-10	LKHevap-15	LKHevap-20	LKHevap-25	LKHevap-35	LKHevap-40	LKHevap-45	LKHevap-50	LKHevap-60	LKHevap-70
Clamp ISO 2037	M1 M2	21 21	21 21	102 21	21 21	21 12	21 21	21 21	102 21	21 21
Union ISO(IDF)	M1 M2	21 21	21 21	102 21	21 21	21 21	21 21	21 21	102 21	21 21
Union DIN/ISO	M1 M2	25 22	30 30	111 30	30 25	30 27	30 30	30 30	111 30	30 30
Union SMS	M1 M2	24 20	35 24	105 24	24 24	24 24	35 35	105 35	24 24	35 35
Union (BS)RJT	M1 M2	27 27	32 27	108 27	27 27	27 22	32 32	108 32	27 27	32 32
Union DS	M1 M2	24 20	24 24	105 24	24 24	24 21	24 24	105 24	24 24	24 24
Union DIN/DIN	M1 M2	25 22	30 30	111 30	30 25	30 27	30 30	111 30	30 30	30 30
J1*		63,5 / 2,5"	101,6 / 4"	76,1 / 3"	76,1 / 3"	76,1 / 3"	101,6 / 4"	76,1 / 3"	101,6 / 4"	76,1 / 3"
J2*		51 / 2"	76,1 / 3"	76,1 / 3"	63,5 / 2,5"	63,5 / 2,5"	101,6 / 4"	101,6 / 4"	101,6 / 4"	101,6 / 4"

* Other dimensions available on request.

ESE01863/8

Flow chart

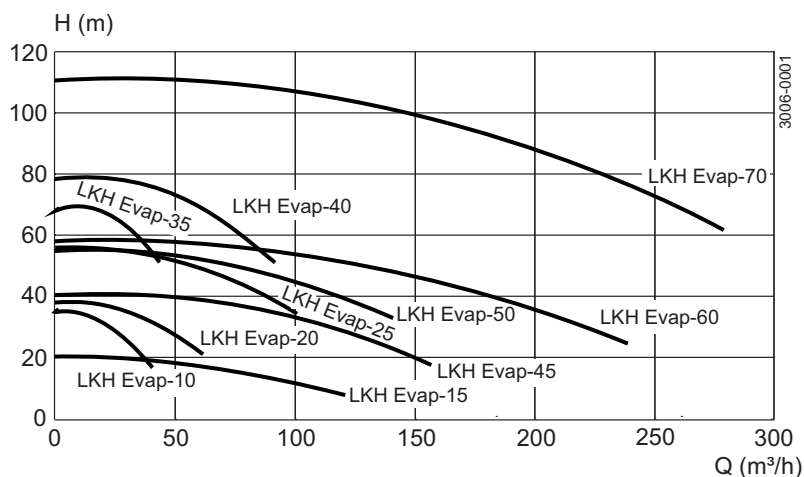

Note: If Clear Flow impeller is mounted the performance can be up to 10% lower than shown on the curves above

Options

- A. Impeller with reduced diameter.
- B. Flushed shaft seal.
- C. Double mechanical shaft seal.
- D. Rotating seal face of Silicon Carbide.
- E. Product wetted elastomers NBR, FPM or FEP.
- F. ½" vertical drain connection.
- G. Product wetted surface finish mechanically polished to $Ra \leq 0.8 \mu\text{m}$.
- H. Surface finish measurement with certificate ($Ra \leq 0.8 \mu\text{m}$).
- I. Inducer (LKH Evap 10 to 50).
- J. Adjustable pads.
- K. Motor for other voltage and/or frequency.
- L. Half speed motor.
- M. Motor with increased safety/flame proof motor.

Ordering

Please state the following when ordering:

- Pump size.
- Connections.
- Impeller diameter.
- Motor size.
- Voltage and frequency.
- Flow, pressure and temperature.
- Density and viscosity of the product.
- Options.

Note!

For further details, see also instruction manual.

Alfa Laval reserves the right to change specifications without prior notification.

How to contact Alfa Laval

Contact details for all countries are continually updated on our website. Please visit www.alfalaval.com to access the information direct.