

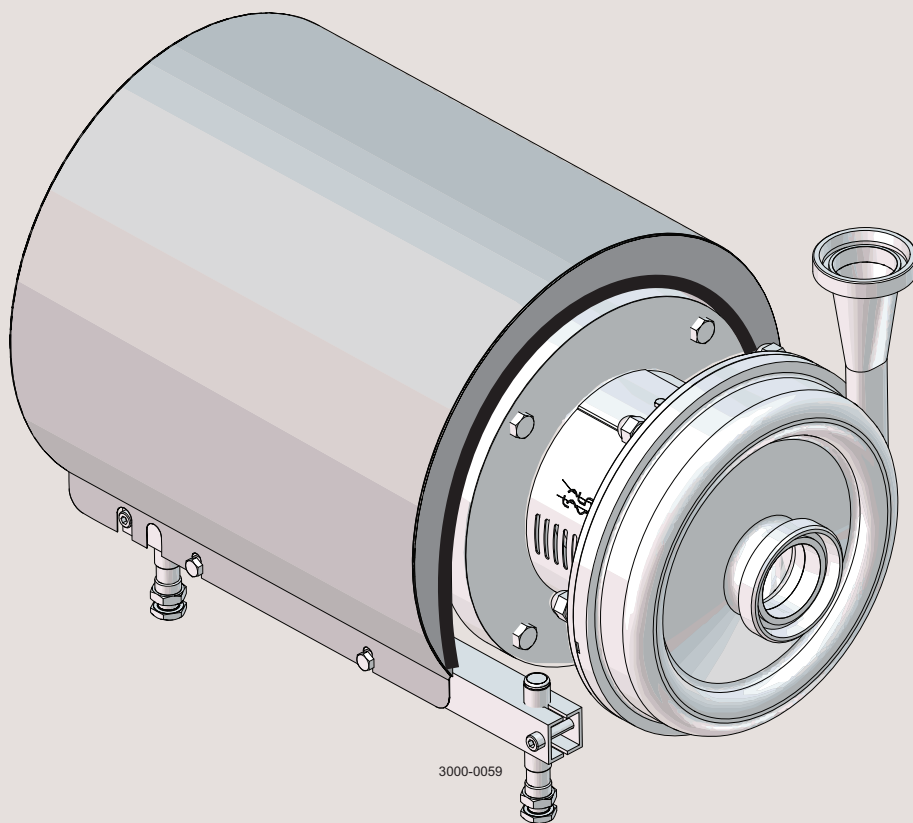

# Instruction Manual

LKH Evap



ESE01861-EN5

2017-09

Original manual



[www.sk-online.com](http://www.sk-online.com)



The information herein is correct at the time of issue but may be subject to change without prior notice

<b>1. EC Declaration of Conformity</b> .....	<b>4</b>
<b>2. Safety</b> .....	<b>5</b>
2.1. Important information .....	5
2.2. Warning signs .....	5
2.3. Safety precautions .....	6
<b>3. Installation</b> .....	<b>7</b>
3.1. Unpacking/delivery .....	7
3.2. Installation .....	8
3.3. Pre-use check .....	10
3.4. Recycling information .....	11
<b>4. Operation</b> .....	<b>12</b>
4.1. Operation/Control .....	12
4.2. Trouble shooting .....	14
4.3. Recommended cleaning .....	15
<b>5. Maintenance</b> .....	<b>16</b>
5.1. General maintenance .....	16
5.2. Cleaning Procedure .....	18
5.3. Dismantling of pump/shaft seals .....	19
5.4. Assembly of pump/single shaft seal .....	21
5.5. Assembly of pump/flushed shaft seal .....	24
5.6. Assembly of pump/double mechanical shaft seal .....	27
5.7. Adjustment of shaft .....	30
<b>6. Technical data</b> .....	<b>33</b>
6.1. Technical data .....	33
6.2. Relubrication intervals .....	34
6.3. Torque Specifications .....	37
6.4. Weight (kg) .....	37
6.5. Noise emission .....	38
<b>7. Parts list and service kits</b> .....	<b>39</b>
7.1. LKH Evap .....	39
7.2. LKH Evap - Wet end .....	40
7.3. LKH Evap - Motor dependent parts .....	42
7.4. LKH Evap - Shaft seal .....	44

# 1 EC Declaration of Conformity

Revision of Declaration of Conformity 2009-12-29

The Designated Company

Alfa Laval Kolding A/S

Company Name

Albuen 31, DK-6000 Kolding, Denmark

Address

+45 79 32 22 00

Phone No.

hereby declare that

Pump

Designation

LKHevap-10, LKHevap-15, LKHevap-20, LKHevap-25, LKHevap-35, LKHevap-40, LKHevap-45, LKHevap-50, LKHevap-60, LKHevap-70, LKHevap-75

Type

From serial number 10.000 to 1.000.000

is in conformity with the following directive with amendments:

- Machinery Directive 2006/42/EC

The person authorised to compile the technical file is the signer of this document

Global Product Quality Manager  
Pump, Valves, Fittings and Tank Equipment

Title

Lars Kruse Andersen

Name

Kolding  
Place

2013-12-03  
Date

Signature



*Unsafe practices and other important information are emphasised in this manual.  
Warnings are emphasised by means of special signs.  
Always read the manual before using the pump!*

---

### 2.1 Important information

---

#### **WARNING**

Indicates that special procedures must be followed to avoid serious personal injury.

#### **CAUTION**

Indicates that special procedures must be followed to avoid damage to the pump.

#### **NOTE**

Indicates important information to simplify or clarify procedures.

---

### 2.2 Warning signs

---

General warning:



Dangerous electrical voltage:



Caustic agents:



## 2 Safety

---

All warnings in the manual are summarised on this page.

Pay special attention to the instructions below so that severe personal injury and/or damage to the pump are avoided.

---

### 2.3 Safety precautions

---

#### Installation:

**Always** read the technical data thoroughly. (See chapter 6 Technical data)  
**Always** use a lifting crane when handling the pump.



#### Pump with Impeller screw:

**Never** start in the wrong direction of rotation with liquid in the pump.

**Always** have the pump electrically connected by authorised personnel. (See the motor instruction)



#### Operation:

**Always** read the technical data thoroughly. (See chapter 6 Technical data)  
**Never** touch the pump or the pipelines when pumping hot liquids or when sterilising.  
**Never** run the pump with both the suction side and the pressure side blocked.  
**Never** run the pump when partially installed or not completely assembled.  
**Necessary** precautions must be taken if leakage occurs as this can lead to hazardous situations.



**Always** handle lye and acid with great care.  
**Never** use the pump for products not mentioned in Alfa Laval pump selection program.



Alfa Laval pump selection program can be acquired from your local Alfa Laval sales company.

---

#### Maintenance:

**Always** read the technical data thoroughly. (See chapter 6 Technical data)  
**Never** service the pump when it is hot.  
**Never** service the pump if pressurized.



#### Motors with grease nipples:

Remember lubrication according to information plate/label on the motor.

**Always** disconnect the power supply when servicing the pump.



**Always** use Alfa Laval genuine spare parts.

---

#### Transportation:

##### Transportation of the pump or the pump unit:

**Never** lift or elevate in any way other than described in this manual  
**Always** drain the pump head and accessories of any liquid  
**Always** ensure that no leakage of lubricants can occur  
**Always** transport the pump in it's upright position  
**Always** ensure that the unit is securely fixed during transportation  
**Always** use original packaging or similar during transportation

---

## 3.1 Unpacking/delivery

### Step 1

Always use a lifting crane when handling the pump (See technical data).

### CAUTION

Alfa Laval cannot be held responsible for incorrect unpacking.

### WARNING:

Be aware that certain pump configurations can tilt, and thereby cause injuries to feet or fingers. The pump should be supported underneath the adaptor, when not installed in the process line.

### Check the delivery for:

1. Complete pump.
2. Delivery note.
3. Motor instructions.

### Step 2

Remove any possible packing materials from the inlet and the outlet.

Avoid damaging the inlet and the outlet.

Avoid damaging the connections for flushing liquid, if supplied.

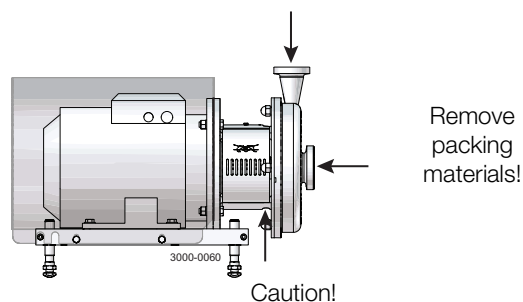

### Step 3

Inspect the pump for visible transport damages.

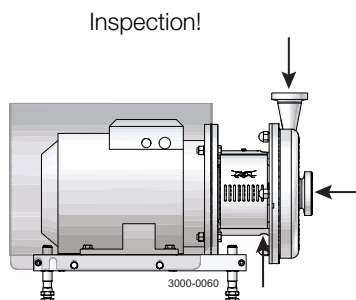

### Step 4

Always remove the shroud, if fitted, before lifting the pump.

Remove the shroud before lifting!

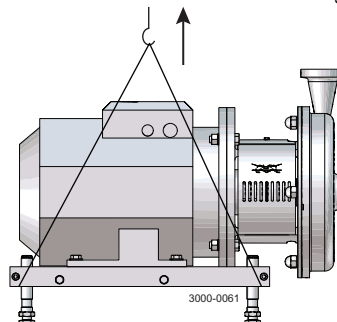

### 3 Installation

Study the instructions carefully and pay special attention to the warnings! Always check the pump before operation.  
- See pre-use check in section 3.3 Pre-use check.  
The large pump sizes are very heavy. Alfa Laval therefore recommends the use of a lifting crane when handling the pump.

#### 3.2 Installation

##### Step 1



**Always** read the technical data thoroughly. (See chapter 6 Technical data)



**Always** use a lifting crane when handling the pump. (See chapter 6 Technical data)



**Always** have the pump electrically connected by authorised personnel. (See the motor instructions).

##### CAUTION

Alfa Laval cannot be held responsible for incorrect installation.

##### WARNING:

Alfa Laval recommend the installation of lockable repair breaker. If the repair breaker is to be used as an emergency stop the colors of the repair breaker must be red and yellow.

**Caution:**  
The pump does not prevent back flow when intentionally or unintentionally stopped. If back flow can cause any hazardous situations precautions must be taken e.g. check valve to be installed in the system preventing above described.

##### Step 2

Ensure at least 0.5 m (1.6 ft) clearance around the pump.

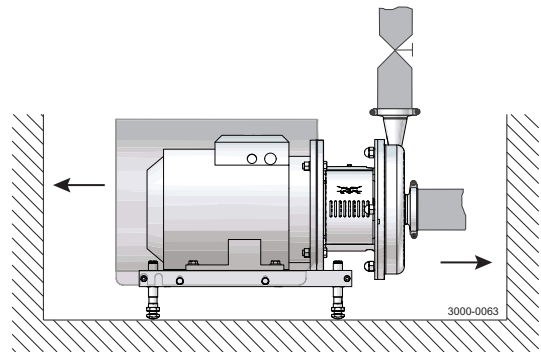

##### Step 3

Check that the flow direction is correct.

O: Outlet

I: Inlet

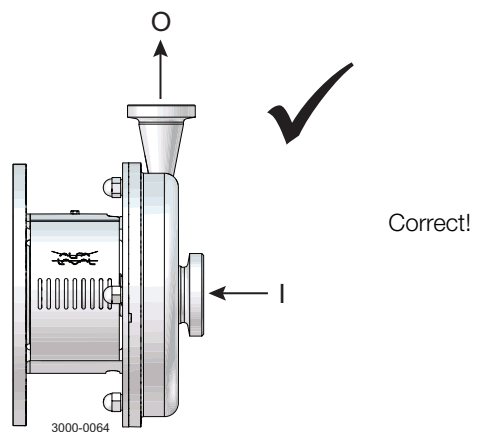



### 3 Installation

Study the instructions carefully and pay special attention to the warnings! Always check the pump before operation.

- See pre-use check in section 3.3 Pre-use check.

The large pump sizes are very heavy. Alfa Laval therefore recommends the use of a lifting crane when handling the pump.

#### Step 4

1. Ensure that the pipelines are routed correctly.
2. Ensure that the connections are tight.

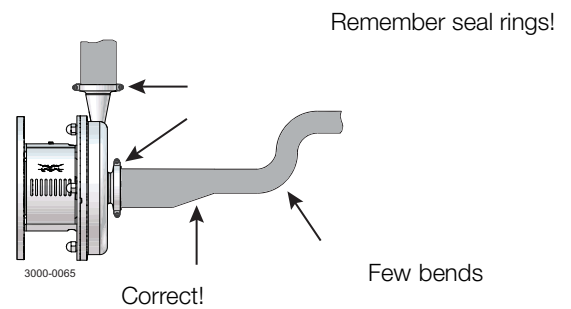

#### Step 5

Avoid stressing the pump.

Pay special attention to:

- Vibrations.
- Thermal expansion of the tubes.
- Excessive welding.
- Overloading of the pipelines.

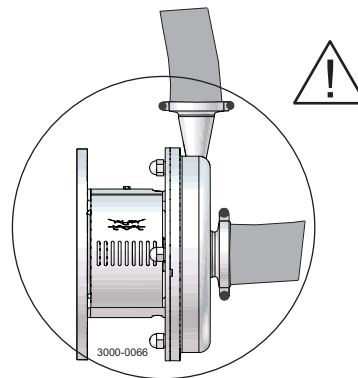

#### Note

In case of shaft seal leakage, the media will drip from the slot in the bottom of the adaptor. In case of shaft seal leakage, Alfa Laval recommends to put a drip tray underneath the slot for collecting the leakage.

### 3 Installation

---

Study the instructions carefully and pay special attention to the warnings!  
Check the direction of rotation of the impeller before operation.  
- See the indication label on the pump.

---

#### 3.3 Pre-use check

---

Check direction of rotation



**Never** start in the wrong direction of rotation with liquid in the pump.

1. Start and stop the motor momentarily.
2. Ensure that the direction of rotation of the motor fan is clockwise as viewed from the rear end of the motor.

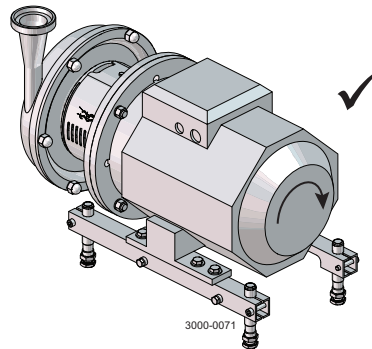

Correct

View from rear end of motor

---

### 3.4 Recycling information

---

- **Unpacking**

- Packing material consists of wood, plastics, cardboard boxes and in some cases metal straps.
- Wood and cardboard boxes can be reused, recycled or used for energy recovery.
- Plastics should be recycled or burnt at a licensed waste incineration plant.
- Metal straps should be sent for material recycling.

- **Maintenance**

- During maintenance oil and wear parts in the machine are replaced.
- All metal parts should be sent for material recycling.
- Worn out or defective electronic parts should be sent to a licensed handler for material recycling.
- Oil and all non metal wear parts must be taken care of in agreement with local regulations.

- **Scrapping**

- At end of use, the equipment shall be recycled according to relevant, local regulations. Beside the equipment itself, any hazardous residues from the process liquid must be considered and dealt with in a proper manner. When in doubt, or in the absence of local regulations, please contact the local Alfa Laval sales company.
-

## 4 Operation

Study the instructions carefully and pay special attention to the warnings!

### 4.1 Operation/Control

#### Step 1



**Always** read the technical data thoroughly. See chapter 6 Technical data

#### CAUTION

Alfa Laval cannot be held responsible for incorrect operation/control.

#### Step 2



**Never** touch the pump or the pipelines when pumping hot liquids or when sterilising.

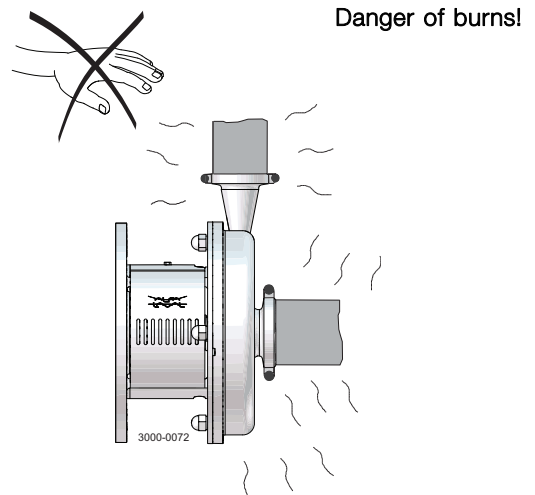

#### Step 3



**Never** run the pump with both the suction side and the pressure side blocked.

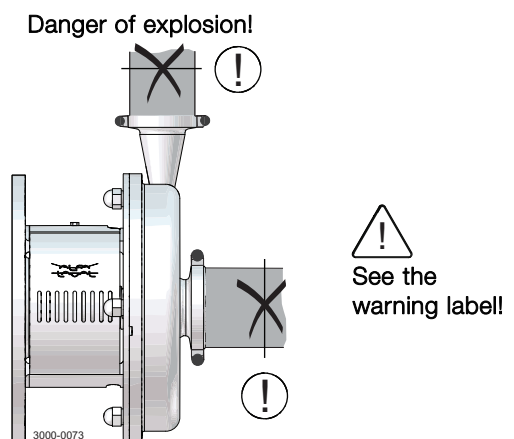

Study the instructions carefully and pay special attention to the warnings!

### Step 4

#### CAUTION

The shaft seal must not run dry.

#### CAUTION

Never throttle the inlet side.

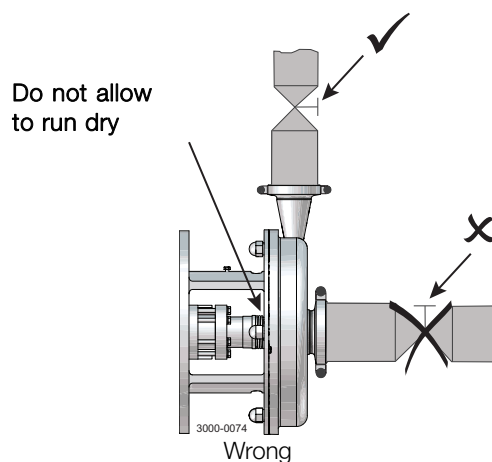

### Step 5

#### Flushed shaft seal:

1. Connect the inlet of the flushing liquid correctly.
2. Regulate the water supply correctly.
3. Observe the steam data.

O: Free outlet

I: Inlet

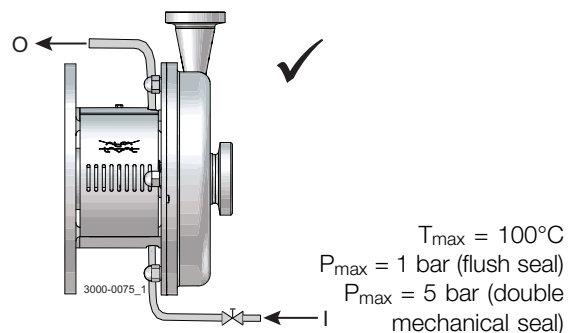

### Step 6

#### Control:

Reduce the capacity and the power consumption by means of:

- Throttling the pressure side of the pump.
- Reducing the impeller diameter.
- Reducing the speed of the motor.

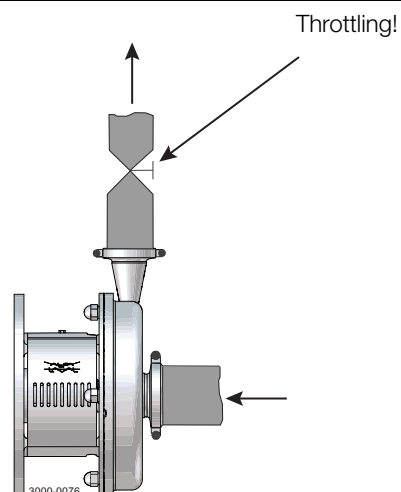

## 4 Operation

*Pay attention to possible faults.  
Study the instructions carefully.*

### 4.2 Trouble shooting

#### NOTE!

Study the maintenance instructions carefully before replacing worn parts.

Problem	Cause/result	Remedy
Overloaded motor	<ul style="list-style-type: none"><li>- Pumping of viscous liquids</li><li>- Pumping of liquids with high density</li><li>- Low outlet pressure (counter pressure)</li><li>- Lamination of precipitates from the liquid</li></ul>	<ul style="list-style-type: none"><li>- Larger motor or smaller impeller</li><li>- Higher counter pressure (throttling)</li><li>- Frequent cleaning</li></ul>
Cavitation: <ul style="list-style-type: none"><li>- Damage</li><li>- Pressure reduction (sometimes to zero)</li><li>- Increasing of the noise level</li></ul>	<ul style="list-style-type: none"><li>- Low inlet pressure</li><li>- High liquid temperature</li></ul>	<ul style="list-style-type: none"><li>- Increase the inlet pressure</li><li>- Reduce the liquid temperature</li><li>- Reduce the pressure drop before the pump</li><li>- Reduce speed</li></ul>
Leaking shaft seal	<ul style="list-style-type: none"><li>- Dry run</li><li>- Incorrect rubber grade</li><li>- Abrasive particles in the liquid</li></ul>	Replace: All wearing parts  If necessary: <ul style="list-style-type: none"><li>- Change rubber grade</li><li>- Select stationary and rotating seal ring in silicon carbide/silicon carbide</li></ul>
Leaking O-ring seals	Incorrect rubber grade	Change rubber grade

The pump is designed for cleaning in place (CIP). CIP = Cleaning In Place.  
Study the instructions carefully and pay special attention to the warnings!  
NaOH = Caustic Soda.  
HNO<sub>3</sub> = Nitric acid.

### 4.3 Recommended cleaning

#### Step 1



**Always** handle lye and acid with great care.

**Caustic danger!**



Always use rubber gloves!



Always use protective goggles!

#### Step 2



**Never** touch the pump or the pipelines when sterilising.

**Danger of burns!**

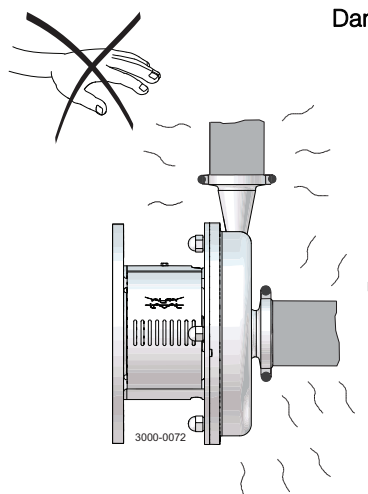

#### Step 3

**Examples of cleaning agents:** Use clean water, free from chlorides.

1. 1% by weight NaOH at 70°C (158°F).

1 kg (2.2 lb) NaOH	+ 100 l (26.4 gal) water	= Cleaning agent.
-----------------------	-----------------------------	-------------------

2.2 l (0.6 gal) 33% NaOH	+ 100 l (26.4 gal) water	= Cleaning agent.
-----------------------------	-----------------------------	-------------------

2. 0.5% by weight HNO<sub>3</sub> at 70°C (158°F).

0.7 l (0.2 gal) 53% HNO <sub>3</sub>	+ 100 l (26.4 gal) water	= Cleaning agent.
-----------------------------------------	-----------------------------	-------------------

1. Avoid excessive concentration of the cleaning agent  
⇒ Dose gradually!
2. Adjust the cleaning flow to the process.  
Sterilization of milk/viscous liquids  
⇒ Increase the cleaning flow!

#### Step 4



**Always** rinse well with clean water after using a cleaning agent.

**Always rinse!**

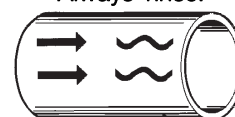

Clean water      Cleaning agent

#### NOTE

The cleaning agents must be stored/disposed of in accordance with current regulations/directives.

## 5 Maintenance

Maintain the pump carefully. Study the instructions carefully and pay special attention to the warnings!  
Always keep spare shaft seals and rubber seals in stock.  
See separate motor instructions.  
Check the pump for smooth operation after service.

### 5.1 General maintenance

#### Step 1



**Always** read the technical data thoroughly. (See chapter 6 Technical data)



**Always** disconnect the power supply when servicing the pump.

#### NOTE

All scrap must be stored/discharged in accordance with current rules/directives.

#### Step 2



**Never** service the pump when it is hot.

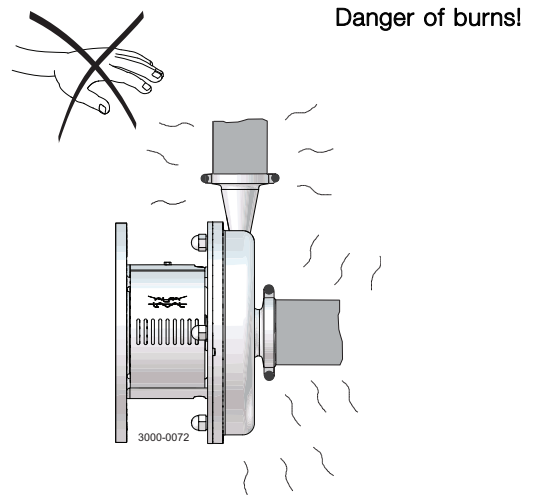

#### Step 3



**Never** service the pump with pump and pipelines under pressure.

#### CAUTION

Fit the electrical connections correctly if they have been removed from the motor during service. (See 3.3 Pre-use check)

#### CAUTION

Pay special attention to the warnings!

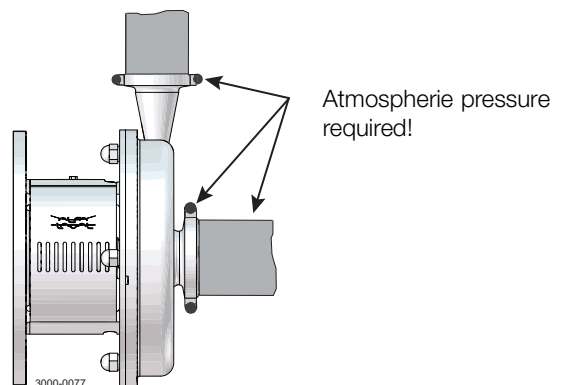

#### Step 4

##### Recommended spare parts:

Order Service Kits from Service kits list  
(See chapter 7 Parts list and service kits).

##### Ordering spare parts

Contact your local Alfa Laval sales company.

##### Note:

If pump is supplied with FEP O-rings. Alfa Laval recommend the casing O-ring is replaced when the pump is maintained.



Maintain the pump carefully. Study the instructions carefully and pay special attention to the warnings!  
 Always keep spare shaft seals and rubber seals in stock.  
 See separate motor instructions.  
 Check the pump for smooth operation after service.

	Shaft seal	Rubber seals	Motor bearings
Preventive maintenance	<b>Replace after 12 months:</b> (one-shift) Complete shaft seal	Replace when replacing the shaft seal	
Maintenance after leakage (leakage normally starts slowly)	<b>Replace at the end of the day:</b> Complete shaft seal	Replace when replacing the shaft seal	
Planned maintenance	<ul style="list-style-type: none"> <li>- Regular inspection for leakage and smooth operation</li> <li>- Keep a record of the pump</li> <li>- Use the statistics for planning of inspections</li> </ul> <b>Replace after leakage:</b> Complete shaft seal	Replace when replacing the shaft seal	Yearly inspection is recommended <ul style="list-style-type: none"> <li>- Replace complete bearing if worn</li> <li>- Ensure that the bearing is axially locked (See motor instructions)</li> </ul>
Lubrication	<b>Before fitting</b> Lubricate the O-rings with silicone grease or silicone oil	<b>Before fitting</b> Silicone grease or silicone oil	See section 6.2 Relubrication intervals

### Pre-use check

#### CAUTION!

Fit the electrical connections correctly if they have been removed from the motor during service.  
 (See 3.3 Pre-use check).

#### Pay special attention to warnings!

1. Start and stop the motor momentarily
2. Ensure that the pump operates smoothly.

## 5 Maintenance

---

### 5.2 Cleaning Procedure

---

#### Cleaning Procedure for Soiled Impeller Screw Tapped Hole:

1. Remove stub shaft (7) per section 4 of Service manual.
2. Submerge and soak Stub Shaft for 5 minutes in COP tank with 2% caustic wash
3. Scrub the blind tapped impeller screw hole vigorously by plunging a clean 1/2" diameter sanitary bristle pipe brush in and out of the hole for two minutes while submerged.
4. Soak Stub Shaft (7) in acid sanitizer for 5 minutes, then scrub blind tapped hole as described in step 3 above.
5. Rinse well with clean water and blow-dry blind tapped hole with clean air.
6. Swab test the inside of the tapped hole to determine cleanliness.
7. Should the swab test fail, repeat steps 2 thru 6 above until swab test is passed.

Should swab testing continue to fail, or time is of the essence, install a new (spare) Stub Shaft (7).

---

Study the instructions carefully. The items refer to the parts list and service kits section.  
 Handle scrap correctly.  
 \* : Relates to the shaft seal.

### 5.3 Dismantling of pump/shaft seals

#### Step 1

1. Unscrew cap nuts (24) and remove washers (24a) and pump casing (29).

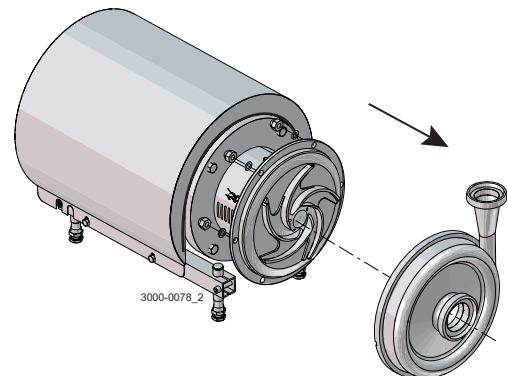

#### Step 2

- Remove screw (23) and safety guard (22).

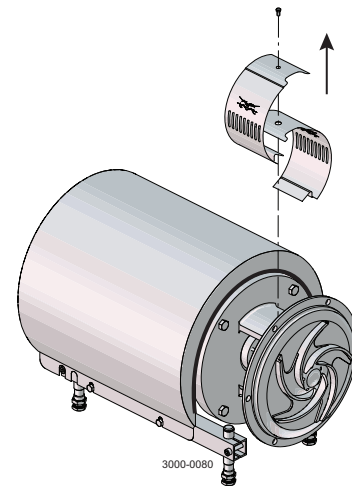

#### Step 3

##### Flushed / Double Mechanical shaft seal:

- Unscrew fittings (42) using a spanner.

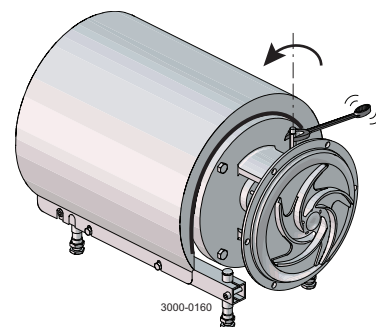

#### Step 4

1. Remove impeller screw (39).
2. Remove impeller (36/37). If necessary, loosen the impeller by knocking gently on the impeller vanes.
3. Remove the O-ring (38) from the impeller.

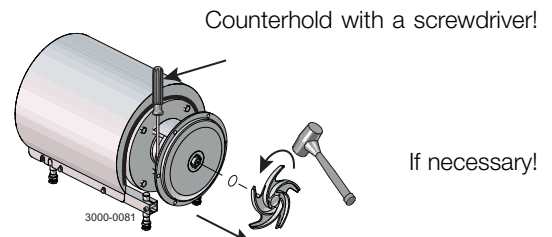

## 5 Maintenance

Study the instructions carefully. The items refer to the parts list and service kits section.

Handle scrap correctly.

\* : Relates to the shaft seal.

### Step 5

1. Pull off the O-ring (26) from back plate (25).
2. Unscrew nuts (20) and remove washers (21) and the back plate.

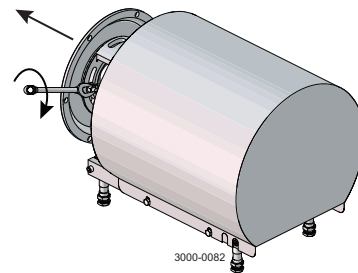

### Step 6

1. Remove the stationary seal ring (11).
2. Remove the O-ring (12) from back plate (25).

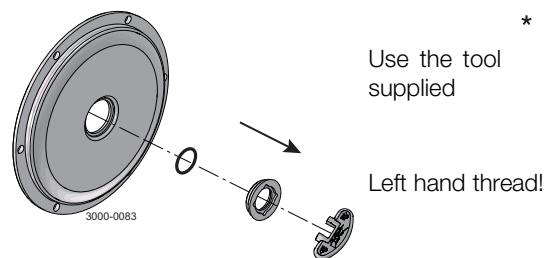

### Step 7

#### Flushed shaft seal:

1. Remove screws (41) and seal housing (40).
2. Pull out lip seal (43) from the seal housing.

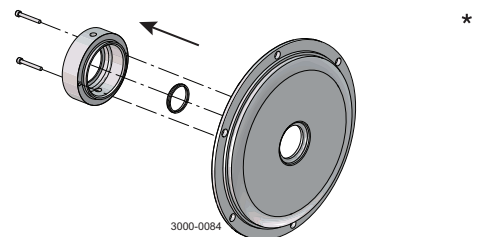

### Step 8

#### Double mechanical shaft seal:

1. Remove screws (41) and seal housing (40a).
2. Remove rotating seal rings (14) and drive ring (52) from spring (13).
3. Remove O-rings (15) from rotating seal rings (14).
4. LKH Evap-70 to 75: Remove cups (54) from rotating seal rings.

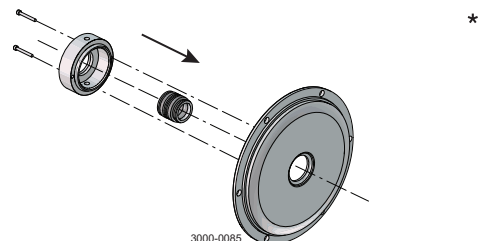

### Step 9

#### Double mechanical shaft seal:

1. Remove stationary seal ring (51) from seal housing (40a).
2. Remove O-ring (50) from stationary seal ring (51).
3. Remove O-ring (44) from seal housing (40a).

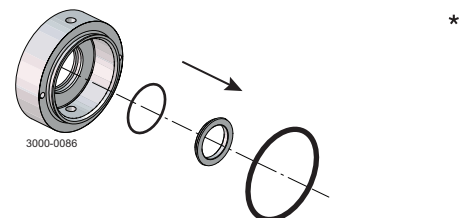

### Step 10

1. Remove the complete shaft seal from stub shaft (7).
2. Remove spring (13) and rotating seal ring (14) from the drive ring (10).

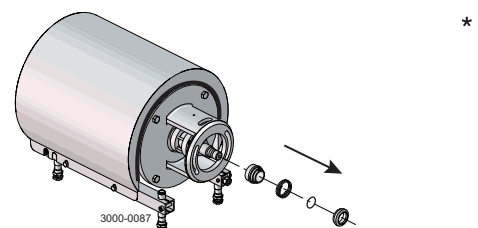

Study the instructions carefully. The items refer to the parts list and service kits section.

Handle scrap correctly.

\* : Relates to the shaft seal.

### 5.4 Assembly of pump/single shaft seal

#### Step 1

1. Remove spring (13).

#### NOTE!

Make sure that O-ring (15) has max. clearance from the sealing surface.

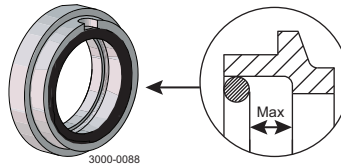

\*

#### Step 2

1. Refit spring (13) on rotating seal ring (14).
2. Fit the spring and the rotating seal ring on drive ring (10).

#### CAUTION

Ensure that the driver on the drive ring enters the notch in the rotating seal ring.

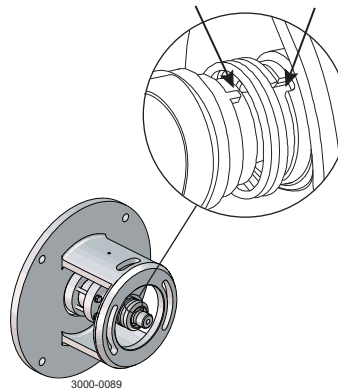

\*

#### Step 3

- Fit the complete shaft seal on stub shaft (7).

#### NOTE!

Make sure that connex pin (8) on the stub shaft enters the notch in drive ring (10).

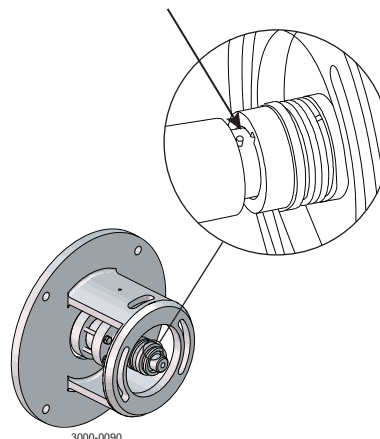

\*

#### Step 4

1. Fit O-ring (12) on stationary seal ring (11) and lubricate.
2. Screw the stationary seal ring into back plate (25).

#### CAUTION

Only tighten by hand to avoid deforming the stationary seal ring.  
(Max 7Nm/5 lbf-ft)

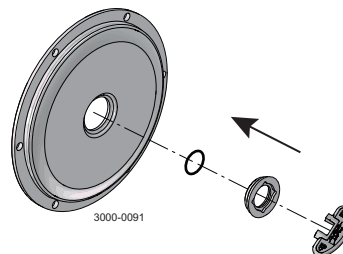

Use the tool  
supplied

Left hand thread!

\*

## 5 Maintenance

Study the instructions carefully. The items refer to the parts list and service kits section.

Handle scrap correctly.

\* : Relates to the shaft seal.

### Step 5

1. Clean the sealing surfaces with contact cleaner before fitting back plate (25).
2. Carefully guide the back plate onto adaptor (16).
3. Fit washers (21) and nuts (20).

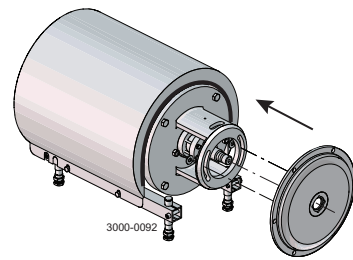

\*

### Step 6

Lubricate O-ring (26) and slide it onto back plate (25).

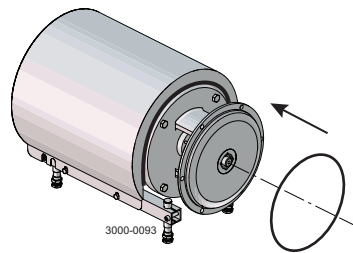

### Step 7

1. Lubricate O-ring (38) and fit it in impeller (37).
2. Lubricate impeller hub with silicone grease or oil.
3. Screw the impeller onto stub shaft (7).
4. Fit impeller screw (39) and tighten.

Torque - 10-60 = 20 Nm (7.4 lbf-ft)

Torque - 70-75 = 50 Nm (37 lbf-ft)

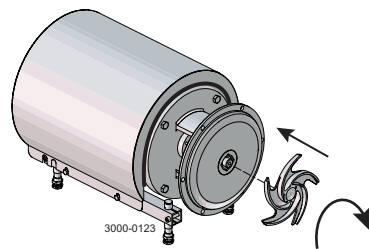

### Step 8

Fit safety guards (22) and screw (23) and tighten.

If pump is not supplied with flush connections the holes in the adaptor shall be covered by the guard.

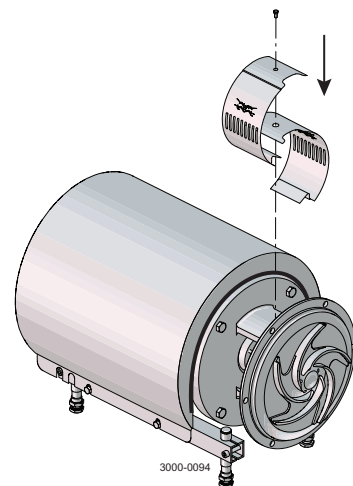

---

Study the instructions carefully. The items refer to the parts list and service kits section.  
Handle scrap correctly.  
\* : Relates to the shaft seal.

---

### Step 9

1. Fit pump casing (29), washers (24a) and cap nuts (24).
2. Adjust pump casing to the right position.
3. Tighten nuts (20) for back plate (25) and tighten cap nuts (24), according to torque values in chapter 6 Technical data.

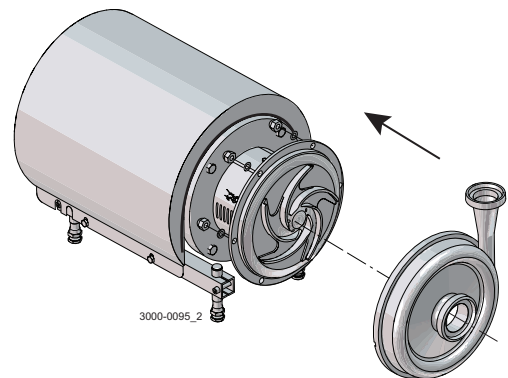

## 5 Maintenance

Study the instructions carefully. The items refer to the parts list and service kits section.

Lubricate the rubber seals before fitting them.

\* : Relates to the shaft seal.

### 5.5 Assembly of pump/flushed shaft seal

#### Step 1

Flushed shaft seal :

LKH Evap-10 to -60 use  $\varnothing 63$ mm tube

LKH Evap-70 to -75 press in lip seal by hand

1. Fit lip seal (43) in seal housing (40).
2. Lubricate O-ring (44) and slide onto the seal housing (40).
3. Fit the seal housing on back plate (25) and tighten screws (41).

Use  $\varnothing 63$  mm tube! (LKH Evap 10-60) \*

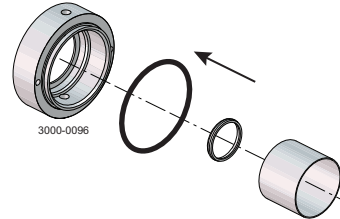

#### Step 2

1. Clean the sealing surfaces with contact cleaner.
2. Fit seal housing (40a) on the back plate (25) and tighten screws (41).

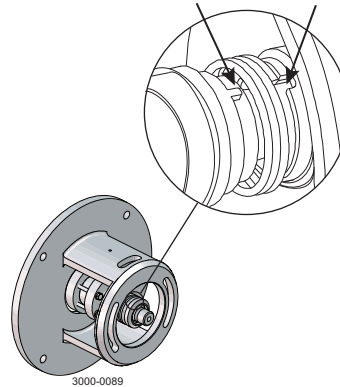

#### Step 3

1. Carefully guide back plate (25) onto adaptor (16).
2. Fit washers (21) and nuts (20).

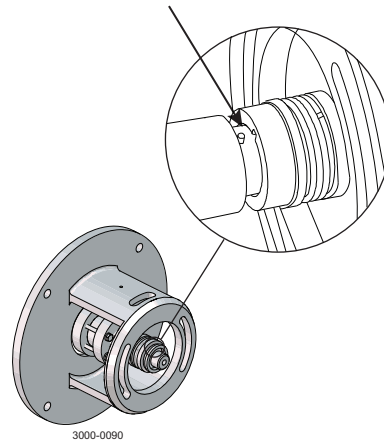

#### Step 4

1. Carefully guide back plate (25) onto adaptor (16).
2. Fit washers (21) and nuts (20).

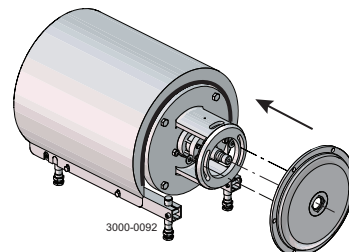



Study the instructions carefully. The items refer to the parts list and service kits section.  
Lubricate the rubber seals before fitting them.  
\* : Relates to the shaft seal.

### Step 5

Lubricate O-ring (26) and slide it onto back plate (25).

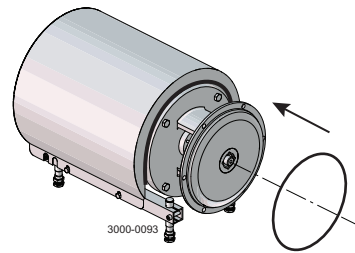

### Step 6

1. Lubricate O-ring (38) and fit it in impeller (37).
  2. Lubricate the impeller hub with silicone grease or oil.
  3. Screw impeller (36/37) onto stub shaft (7).
  4. Fit impeller screw (39) and tighten.
- Torque - 10-60: 20 Nm (7.4 lbf-ft)  
Torque - 70-75: 50 Nm (37 lbf-ft)

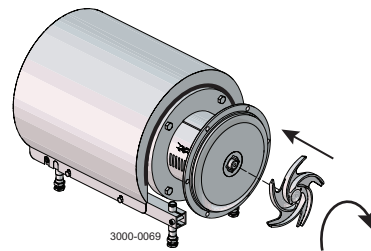

### Step 7

1. Screw fittings (42) into seal housing (40).
2. Tighten with a spanner.

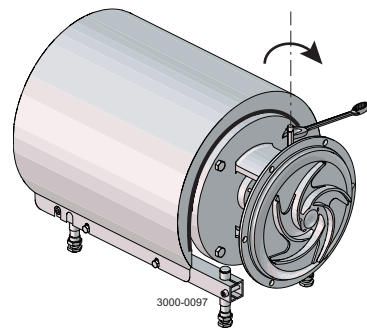

### Step 8

Fit safety guard (22) and screw (23) and tighten.

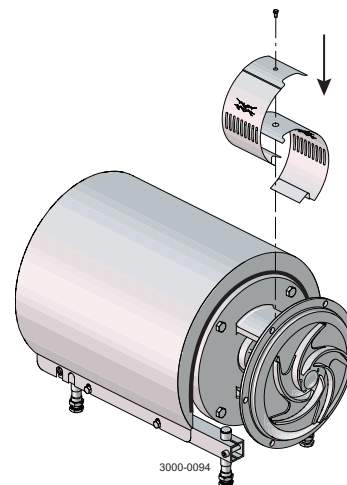

## 5 Maintenance

---

Study the instructions carefully. The items refer to the parts list and service kits section.  
Lubricate the rubber seals before fitting them.  
\* : Relates to the shaft seal.

---

### Step 9

1. Fit pump casing (29).
2. Tighten nuts (20) for back plate (25).
3. Fit washers (24a) and cap nuts (24) and tighten, according to torque values in chapter 6 Technical data.

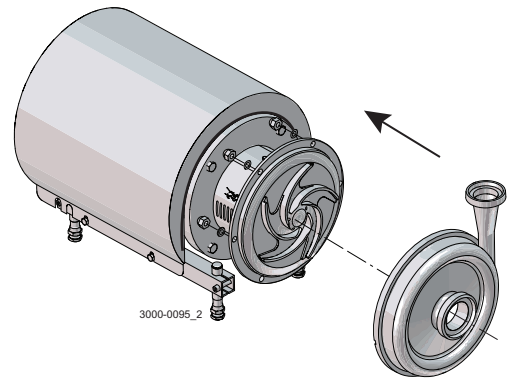

Study the instructions carefully. The items refer to the parts list and service kits section.  
Lubricate the rubber seals before fitting them.  
\* : Relates to the shaft seal.

### 5.6 Assembly of pump/double mechanical shaft seal

#### Step 1

1. Fit O-rings (15) in rotating seal rings (14). \*
2. LKH Evap-70 to -75: Fit cups (54) on rotating seal rings (14).
3. Fit spring (13) on one of the rotating seal rings (14) and place the drive ring (52) in between.

#### Step 2

1. LKH Evap-70 to -75: Turn the drive ring (52) in order to place it correctly on the pump shaft (7).
2. Fit the second rotating ring (14) on the other end of the spring.
3. Place the parts on the stationary seal ring fitted in back plate (25).

Only LKH Evap-70 to -75 \*

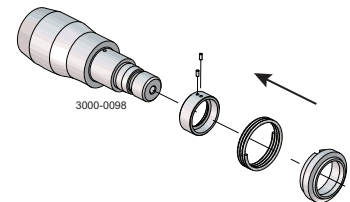
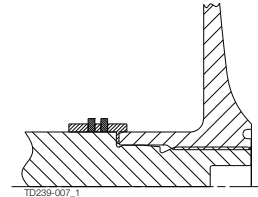

#### NOTE

Ensure that both drive pins on the drive ring enters the notches in rotating seal rings.

#### Step 3

1. Lubricate O-ring (44) and slide onto seal housing (40a).
2. Lubricate O-ring (50) and fit on stationary seal ring (51) and fit this in the seal housing.

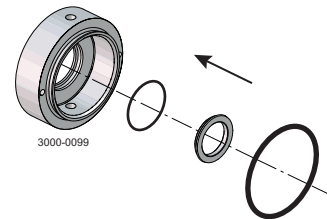

#### Step 4

1. Clean the sealing surfaces with contact cleaner.
2. Fit seal housing (40a) on the back plate (25) and tighten screws (41).

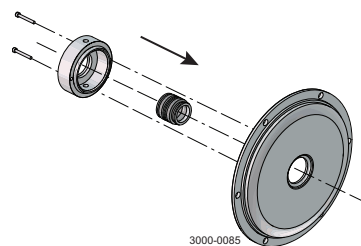

#### Step 5

1. To enable fitting back plate (25) with the shaft seal remove connex pin (8) from stub shaft (7) (if fitted).
2. Carefully guide the back plate onto adaptor (16).
3. Fit washers (21) and nuts (20).

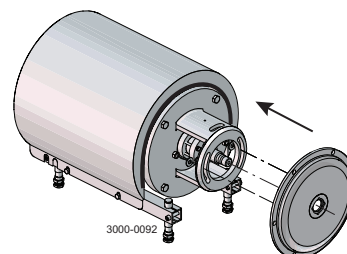

## 5 Maintenance

Study the instructions carefully. The items refer to the parts list and service kits section.

Lubricate the rubber seals before fitting them.

\* : Relates to the shaft seal.

### Step 6

Lubricate O-ring (26) and slide it onto back plate (25).

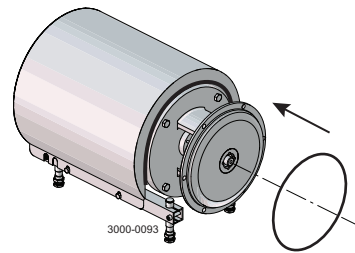

### Step 7

1. Lubricate O-ring (38) and fit it in impeller (36/37).
2. Lubricate the impeller hub with silicone grease or oil.
3. Screw impeller (36/37) onto stub shaft (7).
4. Fit impeller screw (39) and tighten.

Torque - 10-60: 20 Nm (7.4 lbf-ft)

Torque - 70-75: 50 Nm (37 lbf-ft)

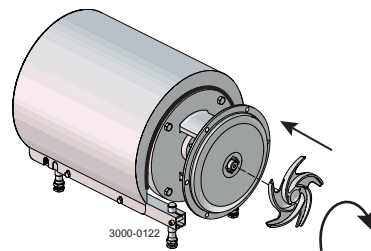

### Step 8

1. Screw fittings (42) into seal housing (40a).
2. Tighten with a spanner.

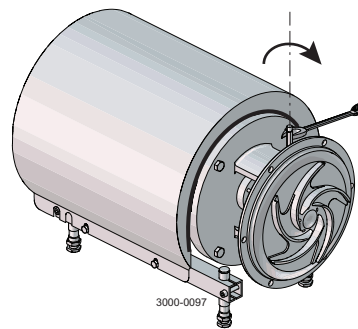

### Step 9

Fit safety guard (22) and screw (23) and tighten.

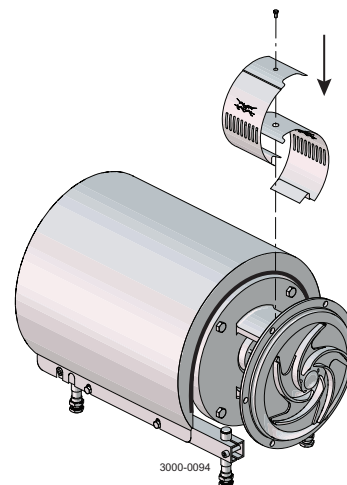

Study the instructions carefully. The items refer to the parts list and service kits section.

Lubricate the rubber seals before fitting them.

\* : Relates to the shaft seal.

### Step 10

1. Fit pump casing (29).
2. Tighten nuts (20) for back plate (25).
3. Fit washers (24a) and cap nuts (24) and tighten, according to torque values in chapter 6 Technical data.

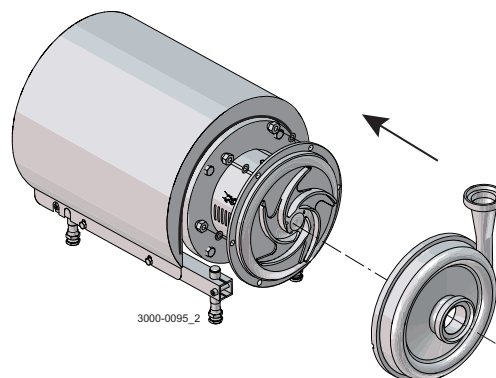

## 5 Maintenance

Study the instructions carefully. The items refer to the parts list and service kits section.

Lubricate the rubber seals before fitting them.

\* : Relates to the shaft seal.

### 5.7 Adjustment of shaft

#### LKH Evap -70 to -75

For securing the best fixture to the motor shaft ensure the following:

- Conical surfaces on pump shaft and compression rings are applied with grease.
- No grease on the motor shaft.
- No grease on the inside diameter of the pump shaft.
- Screws for the compression rings are applied with grease.

#### Step 1

1. Loosen screws (6).
2. Pull off stub shaft (7) together with compression rings (5a,5b).

See special cleaning procedure for tapped hole in stub shaft page 18.

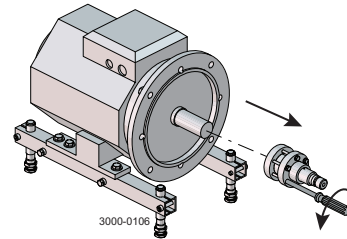

#### Step 2

1. Push stub shaft (7) together with compression rings (5a, 5b) onto the motor shaft.
2. Check that the clearance between the end of the stub shaft and the motor flange is 10-20 mm (0.39 - 0.78 inch).

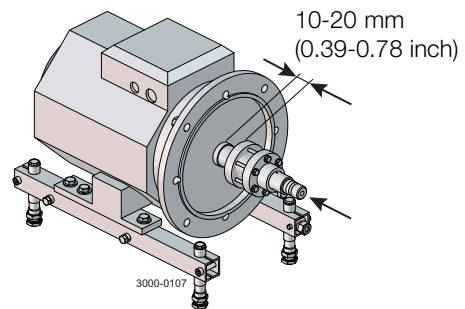

#### Step 3

1. Tighten screws (6) lightly and evenly.
2. Ensure that stub shaft (7) can be moved on the motor shaft.

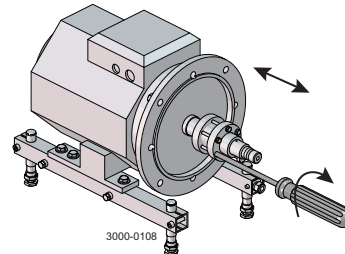

#### Step 4

1. For double mechanical shaft seal:  
Fit drive ring (52) on stub shaft (7).
2. Fit back plate (25), washers (21) and nuts (20) and tighten.

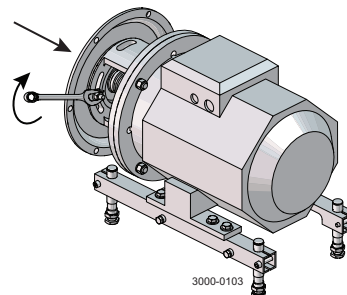

# 5 Maintenance

Study the instructions carefully. The items refer to the parts list and service kits section.  
Lubricate the rubber seals before fitting them.  
\* : Relates to the shaft seal.

### Step 5

- 1. Fit impeller (36/37) on stub shaft (7).
- 2. Ensure that the clearance between the impeller and back plate (25) is correct: 0.5 mm (0.02 inch) for LKH Evap-10 to 60 and 1.0 mm (0.039 inch) for LKH Evap-70 to -75.

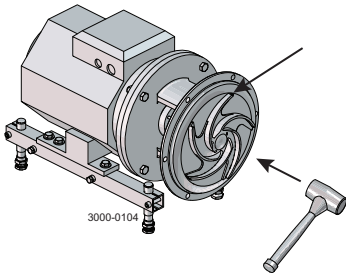

LKH Evap-10 to -60 = 0.5 mm (0.02 inch)  
LKH Evap-70 to -75 = 1.0 mm (0.039 inch)

### Step 6

Clear Flow impeller

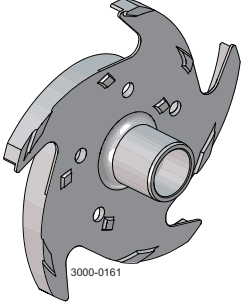

**NOTE!** If pump is mounted with “ClearFlow” impeller the clearance must be adjusted from the knobs to backplate.

### Step 7

- 1. Remove impeller (36/37), back plate (25) and drive ring (52).
- 2. Tighten screws (6) evenly to 15 Nm (11 lbf-ft).

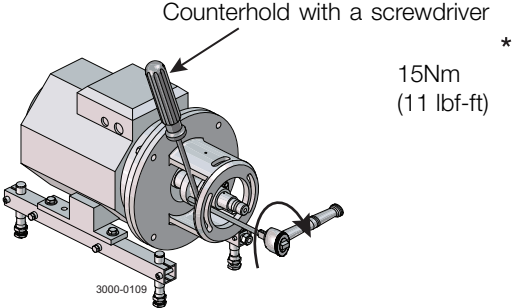





*It is important to observe the technical data during installation, operation and maintenance.  
Inform personnel about the technical data.*

## 6.1 Technical data

The LKH Evap pump is highly efficient and economical centrifugal pump, which meets the requirements of sanitary and gently product treatment and chemical resistance. LKH Evap is available in the following sizes LKH Evap -10, -15, -20, -25, -35, -40, -50, -60, -70 and -75. The instruction manual is part of the delivery. Study the instructions carefully. The large pump sizes are very heavy. Alfa Laval therefore recommends the use of a lifting crane when handling the pump.

Data	
Max. inlet pressure	LKH Evap-10 to -70 (50 Hz): 1000 kPa (10 bar) (145 psi) LKH Evap-10 to -60 (60 Hz): 1000 kPa (10 bar) (145 psi) LKH Evap-70 to -75 (60 Hz): 500 kPa (5 bar) (72.5 psi)
Temperature range	-10°C to +140°C (EPDM) (14 to 284°F)
Max. speed:	4000 rpm
Materials	
Product wetted steel parts	AISI 316L
Other steel parts	Stainless steel
Finish	Standard blasted
Product wetted seals	EPDM (standard)
Other O-rings	EPDM
Alternative seals	Nitrile (NBR), Fluorinated rubber (FPM) and FEP
Shaft seal	
Seal types	External single, flushed or double mechanical seal
Max. temperature flush media	70°C
Max. water pressure (flushed seal)	Normally atmospheric (max. 1 bar) (max. 14.5 psi)
Water consumption (flushed seal)	0.25 - 0.5 l/min. (0.07-0.13 gl)
Max. water pressure LKH Evap-10 to -60 (DMS)	Normally atmospheric (max. 5 bar) (max. 72.5 psi)
Max. water pressure LKH Evap-70 to -75 (DMS)	Normally atmospheric (max. 3 bar) (max. 43.5 psi)
Water consumption (double mechanical seal)	0.25-0.5 l/min. (0.07-0.13 gl)
Material, stationary seal ring	Acid resistant steel with sealing surface of silicon carbide
Material, rotating seal ring	Carbon (standard) or silicon carbide
Material, O-rings	EPDM (standard)
Alternative material, O-rings	Nitrile (NBR), fluorinated rubber (FPM) and FEP
Motor	
<b>IEC LKH Evap-10 to -70</b>	
Standard foot-flanged motor acc. to IEC metric standard 2 poles = 3000/3600 rpm. at 50/60 Hz IP55 (drain hole with labyrinth plug), insulation class F	
Motor sizes (kW), 50 Hz	1.5 - 75 kW
Motor sizes (kW), 60 Hz	1.75 - 86 kW
<b>Nema LKH Evap</b>	
For LKH Evap-10 to -70: Standard foot-flanged motor acc. to NEMA standard. 2 pol = 3600 rpm. at 60 Hz.	
For LKH Evap-75: Standard foot-flanged motor acc. to NEMA standard. 4 pol = 1800 rpm. at 60 Hz.	
Motor sizes (Hp), 60 Hz	1.5 - 2.0 - 3.0 - 5.0 - 7.5 - 10.0 - 15.0 - 20.0 - 25.0 - 30.0 - 40.0 - 50.0 - 60.0 - 75.0 - 100.0 Hp

For further information - see PD sheet.

## 6 Technical data

It is important to observe the technical data during installation, operation and maintenance.  
Inform the personnel about the technical data.

### 6.2 Relubrication intervals

The table is for an internal bearing temperature of 100°C. An increase in temperature of 15°C (ambient or internal in bearings), will reduce the greasing interval and bearing lifetime by 50%. The lubrication interval for vertically mounted pumps is half the value stated in the table.

ABB IEC motors, IE3

Motor power (kW)	LKH5 -90 LKH110 -60* LKH-110* LKHSP LKH UltraPure 50/60 Hz	LKHPF-10 -60 LKH1-10 -60 LKH-110 3300 Bearing 50/60 Hz	LKHPF-70 LKH-120 7200 Bearing 50/60 Hz	LKH-85 7300 Bearing 50/60 Hz
0.75	Permanently lubricated			
1.1	Permanently lubricated			
1.5	Permanently lubricated	Not available		
2.2	Permanently lubricated	Permanently lubricated		
3.0	Permanently lubricated	Not available		
4.0	Permanently lubricated	Permanently lubricated		
5.5	Permanently lubricated	3600h/3000h - DE/NDE:15g*		
7.5	Permanently lubricated	3600h/3000h - DE/NDE:15g*		
11	Permanently lubricated	3100h/2300h - DE/NDE:25g		
15	Permanently lubricated	3100h/2300h - DE/NDE:25g		
18.5	Permanently lubricated	3100h/2300h - DE/NDE:25g		
22	Permanently lubricated	2600h/2000h - DE/NDE:42g	4000h/2200h - DE/NDE:42g	
30	Permanently lubricated		4000h/2800h - DE/NDE:55g	8000h/ - - DE/NDE:40g
37	Permanently lubricated		4000h/2800h - DE/NDE:55g	8000h/ - - DE/NDE:40g
45	Permanently lubricated		2500h/1000h - DE/NDE:55g	8000h/ - - DE/NDE:40g
55	Permanently lubricated		2500h/1000h - DE/NDE:73g	8000h/3000h - DE/NDE:60g
75	Permanently lubricated		1500h/500h - DE/NDE:73g	4000h/1500h - DE/NDE:60g
90				4000h/2800h - DE/NDE:45g
110				4000h/2800h - DE/NDE:45g

\* inlet pressure less than 10 bar (145 psi)

#### Recommended grease types:

##### LKHPF-10/-70 – LKH-110 - LKH-120:

Esso: Unirex N2 or N3 (Lithium complex base)  
Mobil: Mobilith SHC 100 (Lithium complex base)  
Shell: Shell Gadus S5 V100 2 (Lithium complex base)  
Klüber: Klüberplex BEM 41-132 (Special Lithium base)  
FAG: Arcanol TEMP110 (Lithium complex base)  
Lubcon: Turmogrease L 802 EP PLUS (Lithium complex base)

##### \*LKHPF-10/-60 – LKH-110

Klüber: Klüber Asonic HQ72-102 (Polyurea base)

##### LKH-85:

Klüber: Klüberplex Quiet BQH 72-102 (Polyurea base)  
Lubcon: Turmogrease PU703 (Polyurea base)

**WARNING: Polyurea-based grease must not be mixed with Lithium complex base grease and vice versa.**

*It is important to observe the technical data during installation, operation and maintenance.  
Inform the personnel about the technical data.*

### WEG IEC Motors, IE3

Motor power (kW)	LKH-5 -70 LKHI-10 -60* LKH-110* LKHSP, LKH Evap LKH UltraPure 50/60 HZ
0.75	Permanently lubricated
1.1	Permanently lubricated
1.5	Permanently lubricated
2.2	Permanently lubricated
3.0	Permanently lubricated
4.0	Permanently lubricated
5.5	Permanently lubricated
7.5	Permanently lubricated
11	Permanently lubricated
15	Permanently lubricated
18.5	Permanently lubricated
22	10000/10000h - DE/NDE: 18g
30	10000/10000h - DE/NDE: 21g
37	10000/10000h - DE/NDE: 21g
45	Not available
55	5000/5000h - DE/NDE: 27g
75	5000/5000h - DE/NDE: 27g

\* inlet pressure < 10 bar (145 psi)

#### Recommended grease types:

Mobil                      POLYREX EM 103

## 6 Technical data

*It is important to observe the technical data during installation, operation and maintenance.  
Inform the personnel about the technical data.*

**Table 1. Sterling Nema motors**

Motor RPM	Frame VS. HP	Type of service Standard 8 hrs/day	Heavy duty 24 hrs/day
3600	143T - 286TS 1.5 - 30	*	*
	324TS - 455TS 40 - 150	6 Months	2 Months
1800	143T - 256T 1 - 20	*	*
	284T - 326T 25 - 50	4 Months	18 Months
	364T - 445T 60 - 150	9 Months	3 Months
1200	143T - 256T 0.75 - 10	*	*
	284T - 326T 15 - 30	4 Years	18 Months
	364T - 445T 40 - 125	1 Year	4 Months

\* Motor of this size normally do not have bearings that can be re-lubricated.  
These bearings should be replaced at least every 5 years for 8 hr/day service, or every 2 years for 24 hr/day service.

**Warning: Bearing grease is Klüber NBU-15 - DO NOT SUBSTITUTE!**

*It is important to observe the technical data during installation, operation and maintenance.  
Inform the personnel about the technical data.*

### 6.3 Torque Specifications

Below table specifies the tightening torques for the screws, bolts and nuts in this pump.  
Always use below torques if no other values are stated. This can be a matter of personal safety.

Size	Tightening torque	
	Nm	lbf-ft
M8	20	14.8
M10	40	29.5
M12	67	49.0
M14	110	81.0

### 6.4 Weight (kg)

Pump Type: LKHevap

Size	90		100		112		132		160		180		200		250	
	1.5kW	2.2kW	3kW	4kW	5.5kW	7.5kW	11kW	15kW	18.5kW	22kW	30kW	37kW	45kW	55kW	75kW	
10	53	55	70	75												
15			73	78	95											
20	55	57	72	77	94	108										
25				81	98	112	171	185								
35				81	98	112	171	185								
40						115	174	188	206	225						
45				82	99	113	172	186								
50					101	115	174	188	206	225						
60					102	116	175	189	207	226	334					
70					138	152	196	210	228	259	365	380	396	522	557	

Weight can vary depending of configuration. Weight is only to be seen as a reference value during handling, transporting and packaging.

## 6 Technical data

*It is important to observe the technical data during installation, operation and maintenance.  
Inform the personnel about the technical data.*

### 6.5 Noise emission

Pump Type	Sound pressure level (dBA)
LKH-5	60
LKH-10	69
LKH-15	72
LKH-20	70
LKH-25	74
LKH-35	71
LKH-40	75
LKH-45	70
LKH-50	75
LKH-60	77
LKH-70	88
LKH-75	79
LKH-85	86
LKH-90	75
LKH-112	70
LKH-113	69
LKH-114	68
LKH-122	75
LKH-123	77
LKH-124	80
SolidC-1	68
SolidC-2	72
SolidC-3	73
SolidC-4	72
MR-166	76
MR-185	82
MR-200	81
MR-300	82
GM	54
FM-OS	61

The above LKH noise levels are the same for LKHDPF, LKHDI, LKH UltraPure, LKH Evap, LKHHex.  
The above SolidC noise levels are the same for SolidC UltraPure.

The noise measurements have been carried out with original motor and shroud, approximately at the Best Efficiency Point (BEP) with water at ambient temperature and at 50 Hz.

Very often the noise level generated by the flow through the process system (eg. valves, pipes, tanks etc.) is much higher than what is generated by the pump itself. Therefore it is important to consider the noise level from the total system and take the necessary precautions with regards to personal safety if required.

The drawing shows LKH Evap pump.  
The items refer to the parts lists in the following sections to

## 7.1 LKH Evap

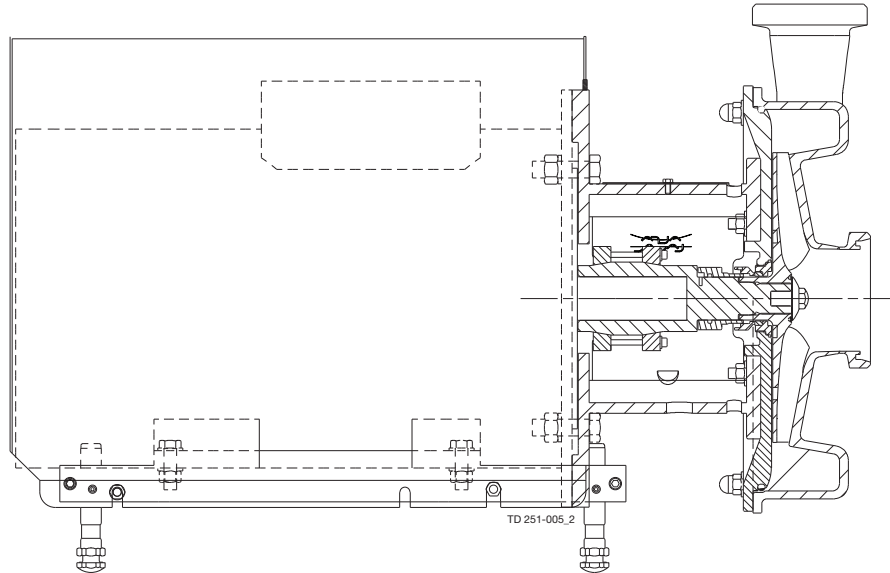

US legs are different to the ones shown. For further information see US Spare Part.  
LKH-75: USA version only, no shroud, US leg set

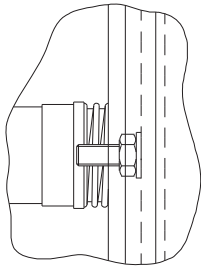

3000-0113\_1  
Fitting of back plate

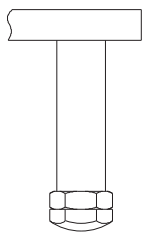

TD 239-008\_1  
55-75 kW  
Fitting of legs

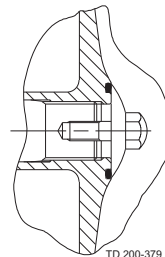

TD 200-379\_1  
Impeller screw

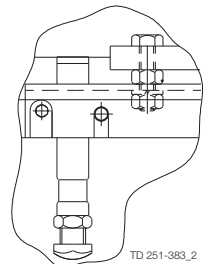

TD 251-383\_2  
Only used for 3 kW  
Fitting of legs

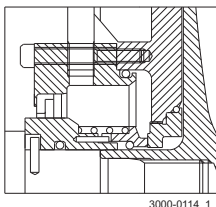

3000-0114\_1  
Flushed shaft seal

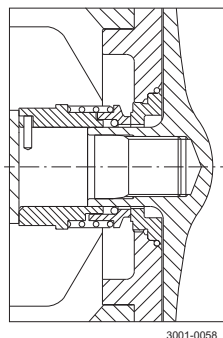

3001-0058  
Single shaft seal

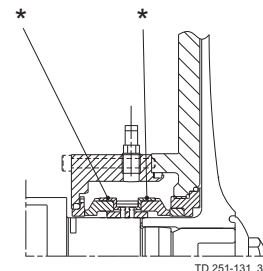

TD 251-131\_3  
\* Double mechanical shaft seal  
for LKH-70

# 7 Parts list and service kits

The drawing shows LKH Evap pump.  
The items refer to the parts lists in the following sections to

## 7.2 LKH Evap - Wet end

DMSS = Double Mechanical Shaft Seal. FSS = Flushed Shaft Seal

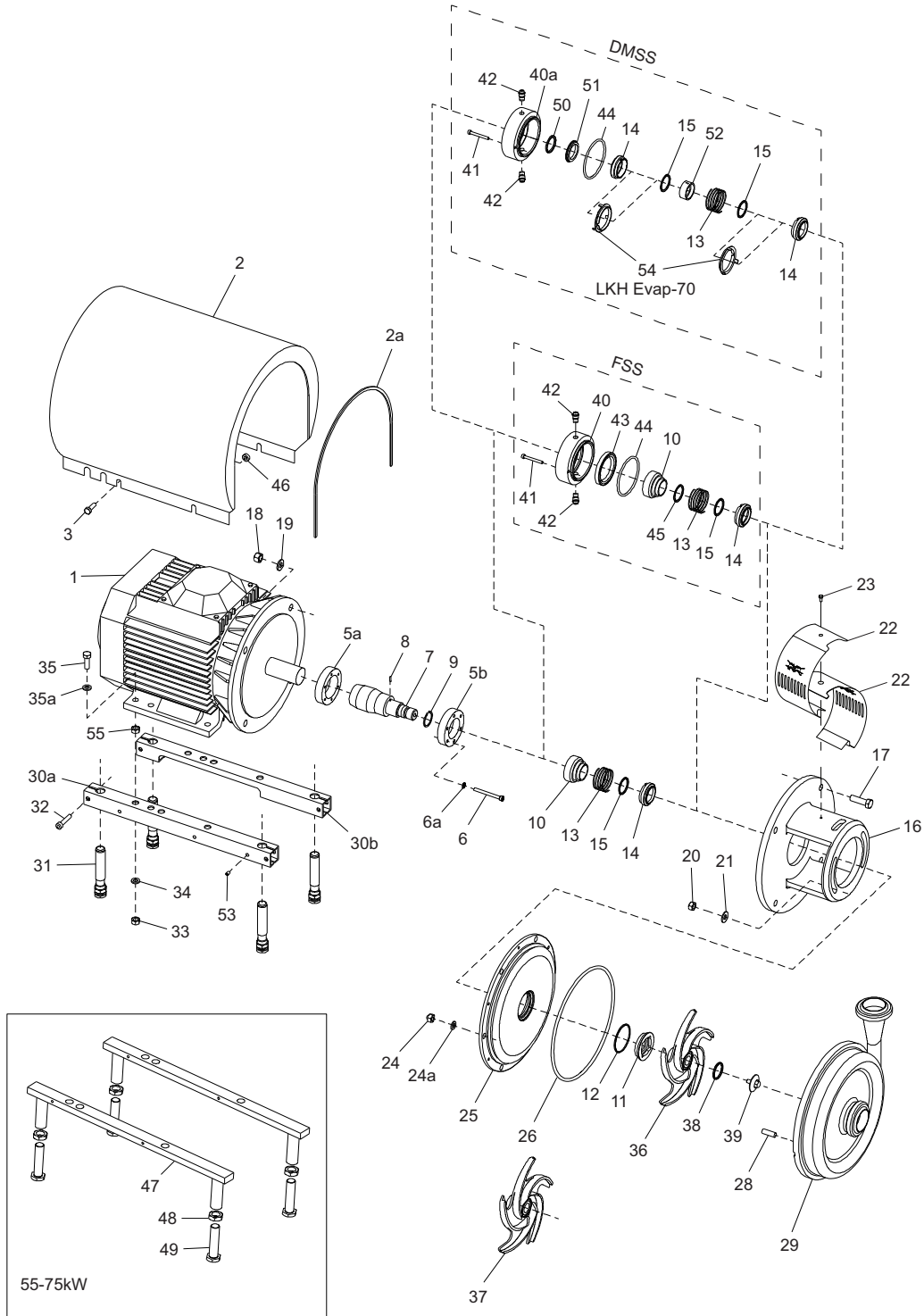

3006-0002



## 7 Parts list and service kits

The drawing shows LKH Evap pump.

The items refer to the parts lists in the following sections to

### Parts list

Pos.	Qty	Denomination
20	2	Nut
21	2	Washer
24	6	Cap nut
24a	6	Washer
25	1	Back plate
26 □♦○★▲▲	1	O-ring
28	6	Bolt
29	1	Pump casing
36	1	Impeller
37	1	Impeller, ClearFlow
38 □♦○★▲▲	1	O-ring
39	1	Impeller screw

# 7 Parts list and service kits

The drawing shows LKH Evap pump.  
The items refer to the parts lists in the following sections to

## 7.3 LKH Evap - Motor dependent parts

DMSS = Double Mechanical Shaft Seal. FSS = Flushed Shaft Seal

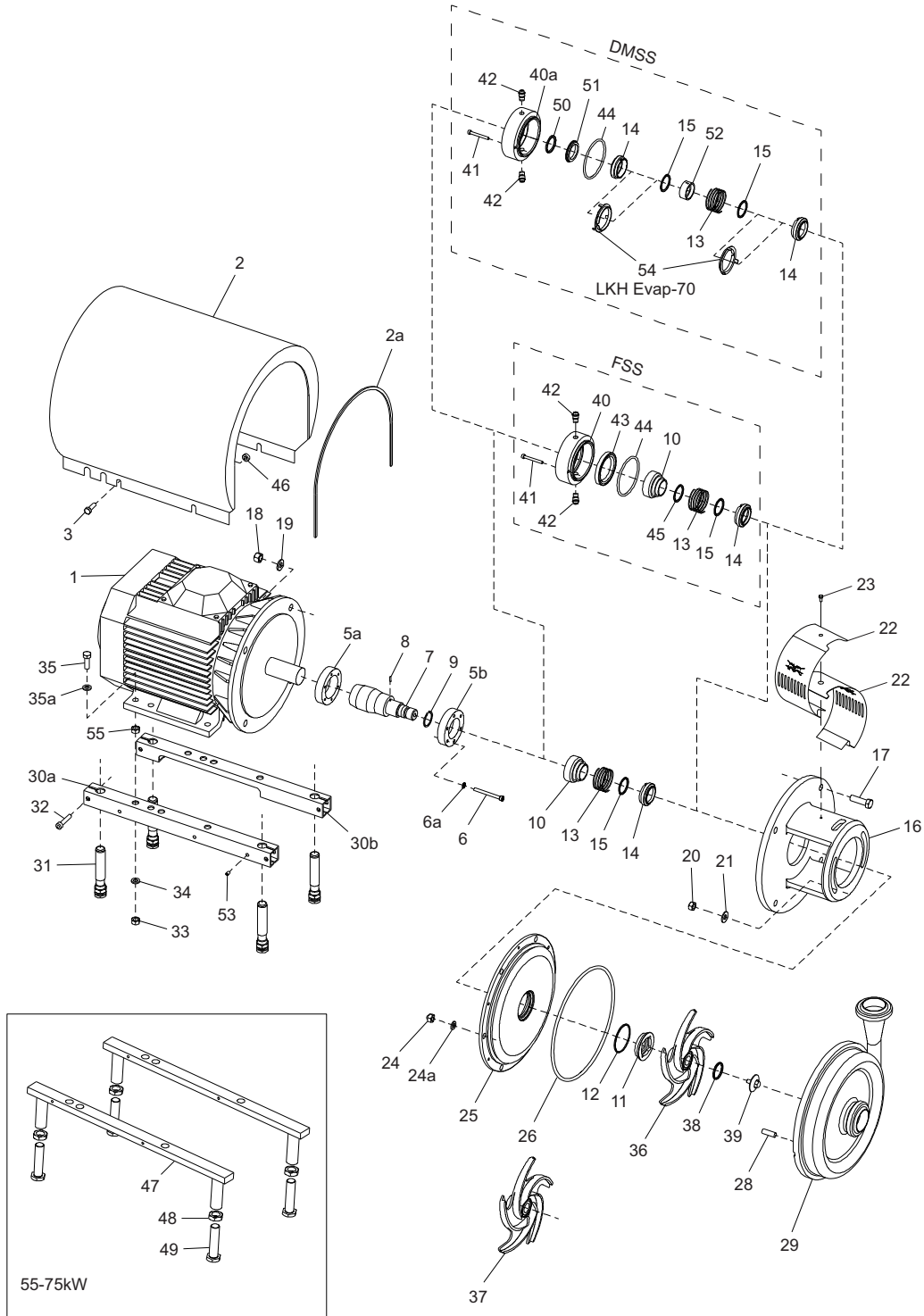

## 7 Parts list and service kits

The drawing shows LKH Evap pump.

The items refer to the parts lists in the following sections to

### Parts list

Pos.	Qty	Denomination
1	1	Motor ABB
2	1	Shroud
2a	1	Edge list (Included in pos. 2)
3	4	Screw
5a	1	Compression ring with thread
5b	1	Compression ring without thread
6	6	Screw
6a	6	Washer
7	1	Shaft incl. pin
8	1	Connex pin
9	1	Retaining ring
16	1	Adaptor
17	4	Screw for adaptor
18	4	Nut for adaptor
19	4	Washer for adaptor
22	1	Safety guard set
23	1	Screw for safety guard
30a	1	Support bar, right
30b	1	Support bar, left
31	4	Leg
32	4	Screw
33	4	Nut
34	4	Spring washer
35	4	Screw
35a	4	Washer
46	4	Distance sleeve
47	2	Leg bracket
48	4	Nut for leg
49	4	Screw for leg
53	4	Pivot screw
55	4	Nut

## 7 Parts list and service kits

The drawing shows LKH Evap pump.

The items refer to the parts lists in the following sections to

### 7.4 LKH Evap - Shaft seal

Single Shaft Seal

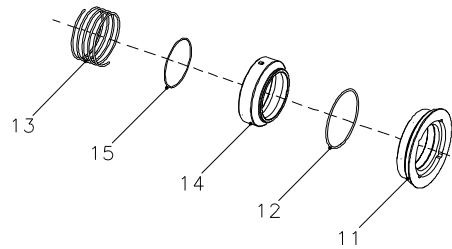

Flushed Shaft Seal

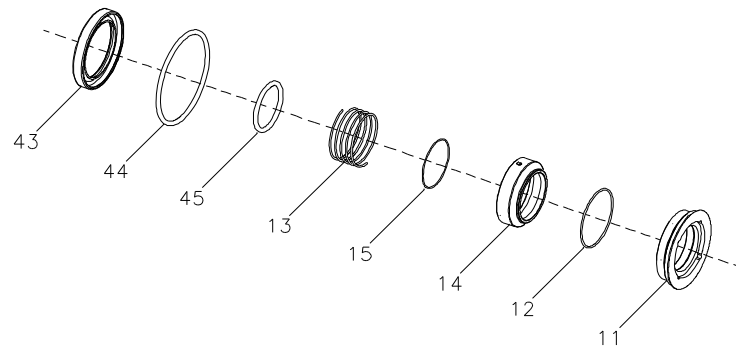

Double Mechanical Shaft Seal

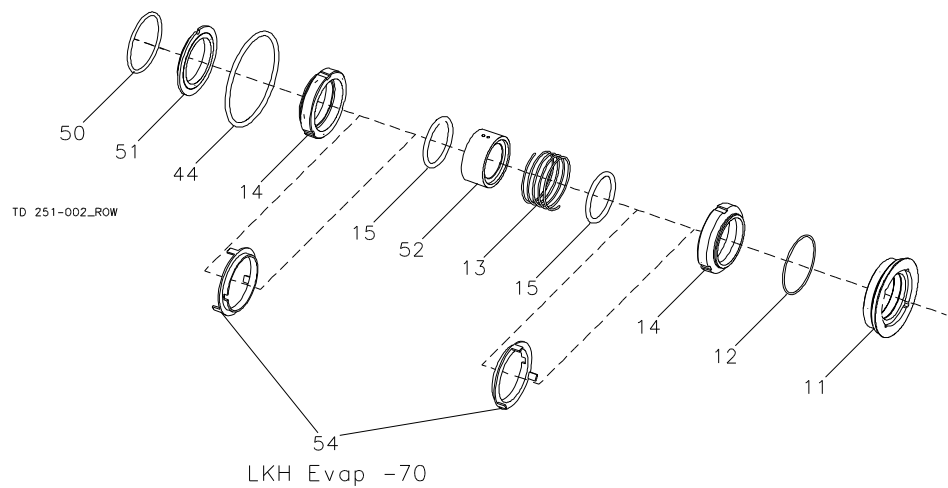

## 7 Parts list and service kits

The drawing shows LKH Evap pump.

The items refer to the parts lists in the following sections to

### Parts list

Pos.	Qty	Denomination
□		Complete shaft seal
★		Complete shaft seal
◆		Complete shaft seal
△		Complete shaft seal
○		Complete shaft seal
▲		Complete shaft seal
10	1	Drive ring
11	1	Stationary seal ring
12	1	O-ring
13	1	Spring
14	1	Rotating seal ring
15	1	O-ring
40	1	Seal housing
40a	1	Seal housing
41	2	Screw for seal housing
42	2	Fittings
43	1	Lip seal
44	1	O-ring for seal housing
45	1	O-ring for drive ring
50	1	O-ring
51	1	Sec. stationary seal ring
52	1	Drive ring
54	2	Cup

### Service kits

Denomination	EPDM	NBR	FPM	FEP
<b>Service kit for single shaft seal C/SiC</b>				
◆ Service kit, C/SiC (LKH Evap-10/15) .....	9611922114	9611922115	9611922116	9611922117
◆ Service kit, C/SiC (LKH Evap-20) .....	9611922122	9611922123	9611922124	9611922125
◆ Service kit, C/SiC (LKH Evap-25/35/45) .....	9611922182	9611922183	9611922184	9611922185
◆ Service kit, C/SiC (LKH Evap-40/50/60) .....	9611922130	9611922131	9611922132	9611922133
◆ Service kit, C/SiC (LKH Evap-70) .....	9611922238	9611922239	9611922240	9611922241
◆ Service kit, C/SiC (LKH Evap-75) .....	9611922976	9611922977	9611922978	
<b>Service kit for single shaft seal SiC/SiC</b>				
◇ Service kit, SiC/SiC (LKH Evap-10/15) .....	9611922550	9611922551	9611922552	9611922553
◇ Service kit, SiC/SiC (LKH Evap-20) .....	9611922574	9611922575	9611922576	9611922577
◇ Service kit, SiC/SiC (LKH Evap-25/35/45) .....	9611922598	9611922599	9611922600	9611922601
◇ Service kit, SiC/SiC (LKH Evap-40/50/60) .....	9611922623	9611922624	9611922625	9611922626
◇ Service kit, SiC/SiC (LKH Evap-70) .....	9611922643	9611922644	9611922645	9611922646
◇ Service kit, SiC/SiC (LKH Evap-75) .....	9611922985	9611922986	9611922987	
<b>Service kit for flushed shaft seal C/SiC</b>				
* Service kit, C/SiC (LKH Evap-10/15) .....	9611922118	9611922119	9611922120	9611922121
* Service kit, C/SiC (LKH Evap-20) .....	9611922126	9611922127	9611922128	9611922129
* Service kit, C/SiC (LKH Evap-25/35/45) .....	9611922190	9611922191	9611922192	9611922193
* Service kit, C/SiC (LKH Evap-40/50/60) .....	9611922134	9611922135	9611922136	9611922137
* Service kit, C/SiC (LKH Evap-70) .....	9611922242	9611922243	9611922244	9611922245
* Service kit, C/SiC (LKH Evap-75) .....	9611922979	9611922980	9611922981	
<b>Service kit for flushed shaft seal SiC/SiC</b>				
◊ Service kit, SiC/SiC (LKH Evap-10/15) .....	9611922558	9611922559	9611922560	9611922561
◊ Service kit, SiC/SiC (LKH Evap-20) .....	9611922582	9611922583	9611922584	9611922585

## 7 Parts list and service kits

The drawing shows LKH Evap pump.

The items refer to the parts lists in the following sections to

	Denomination	EPDM	NBR	FPM	FEP
⊙	Service kit, SiC/SiC (LKH Evap-25/35/45) .....	9611922606	9611922607	9611922608	9611922609
⊙	Service kit, SiC/SiC (LKH Evap-40/50/60) .....	9611922631	9611922632	9611922633	9611922634
⊙	Service kit, SiC/SiC (LKH Evap-70) .....	9611922647	9611922648	9611922649	9611922650
⊙	Service kit, SiC/SiC (LKH Evap-75) .....	9611922988	9611922989	9611922990	
<b>Service kit for double mechanical shaft seal C/SiC</b>					
Δ	Service kit, C/SiC (LKH Evap-10/15) .....	9611922210	9611922211	9611922212	9611922213
Δ	Service kit, C/SiC (LKH Evap-20) .....	9611922218	9611922219	9611922220	9611922221
Δ	Service kit, C/SiC (LKH Evap-25/35/45) .....	9611922226	9611922227	9611922228	9611922229
Δ	Service kit, C/SiC (LKH Evap-40/50/60) .....	9611922234	9611922235	9611922236	9611922237
Δ	Service kit, C/SiC (LKH Evap-70) .....	9611922416	9611922417	9611922418	9611922419
Δ	Service kit, C/SiC (LKH Evap-75) .....	9611922982	9611922983	9611922984	
<b>Service kit for double mechanical shaft seal SiC/SiC</b>					
•	Service kit, SiC/SiC (LKH Evap-10/15) .....	9611922566	9611922567	9611922568	9611922569
•	Service kit, SiC/SiC (LKH Evap-20) .....	9611922590	9611922591	9611922592	9611922593
•	Service kit, SiC/SiC (LKH Evap-25/35/45) .....	9611922614	9611922615	9611922616	9611922617
•	Service kit, SiC/SiC (LKH Evap-40/50/60) .....	9611922639	9611922640	9611922641	9611922642
•	Service kit, SiC/SiC (LKH Evap-70) .....	9611922651	9611922652	9611922653	9611922654
•	Service kit, SiC/SiC (LKH Evap-75) .....	9611922991	9611922992	9611922993	



**How to contact Alfa Laval**

Contact details for all countries are continually updated on our website.

Please visit [www.alfalaval.com](http://www.alfalaval.com) to access the information directly.

© Alfa Laval Corporate AB

This document and its contents is owned by Alfa Laval Corporate AB and protected by laws governing intellectual property and thereto related rights. It is the responsibility of the user of this document to comply with all applicable intellectual property laws. Without limiting any rights related to this document, no part of this document may be copied, reproduced or transmitted in any form or by any means (electronic, mechanical, photocopying, recording, or otherwise), or for any purpose, without the expressed permission of Alfa Laval Corporate AB. Alfa Laval Corporate AB will enforce its rights related to this document to the fullest extent of the law, including the seeking of criminal prosecution.