



**I Application**

The bottom side entry agitators are used in process and storage tanks in the applications of the food-processing industry.  
The main application is agitation of low viscosity products like wine, oil, milk, beer, alcohol, etc. in large volume tanks.

**I Operating principle**

The LR agitators are driven by geared motors and the LM agitators are provided with direct motors.  
These agitators are installed in a slanted position.  
The rotation of the propeller creates a flow that impells the product to the bottom of the tank and then raises up to the surface along the wall opposite to the agitator. The effect is promoted if the bottom is rounded.  
The agitator is installed decentralized to enhance the circular flow. Thus, a complete homogenization of the product is achieved.

**I Design and features**

- Side-entry agitator.
- Internal mechanical seal: EN12756 (DIN 24960 L1K).
- Economical for use in large volume tanks.
- Robust and sanitary design.
- Easy maintenance.
- The propeller fixed to the shaft by means of a threaded connection and a gasket.
- Helical geared motors with food-grade oil.
- Motor: 3 ph, 230/400 V, 50 Hz, IP55, 1500 rpm.
- Marine propeller (Type10).

**I Materials**

Parts in contact with the product	AISI 316L
Lantern and bearing support	GG 15
Mechanical seal	C/SiC/EPDM
Gaskets	EPDM
Surface finish	Ra ≤ 0,8 µm

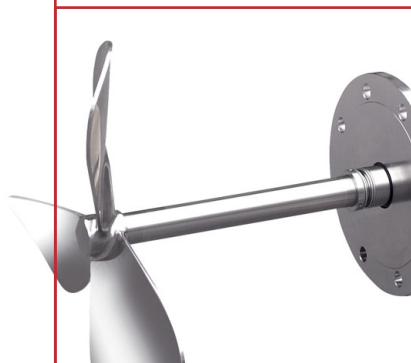

Propeller Type 19



**I Options**

SiC/SiC mechanical seal.

Double mechanical seal.

Gaskets: FPM.

Safety packing.

High flow (Type 19) propeller for LR agitators.

St.St. motor shroud.

Motors with other protections.

ATEX (LR) model available.

**I Technical specifications**

Type	Flow <sup>(1)</sup> [m <sup>3</sup> /h]	Tank <sup>(2)</sup> [m <sup>3</sup> ]	Speed [rpm]	Power [kW]	Weight [kg]
LR 1.10-20005-1-325	248	5-20	200	0,55	54
LR 1.10-20007-1-400	460	20-50		0,75	57
LR 1.10-20015-1-500	920	50-100		1,5	64
LR 1.10-20030-1-600	1555	100-150		3	77
LR 1.10-20040-1-650	1978	150-200		4	135

Type	Flow <sup>(1)</sup> [m <sup>3</sup> /h]	Tank <sup>(2)</sup> [m <sup>3</sup> ]	Speed [rpm]	Power [kW]	Weight [kg]
LM 1.10-4015-1-175	280	5-20	1500	1,5	46
LM 1.10-4030-1-200	420	20-50		3	56
LM 1.10-4055-1-225	594	50-80		5,5	66
LM 1.10-4075-1-250	820	80-140		7,5	75
LM 1.10-4110-1-275	1086	140-200		11	145
LM 1.10-6011-1-200	275	5-20	1000	1,1	48
LM 1.10-6022-1-225	390	20-60		2,2	62
LM 1.10-6030-1-250	560	20-60		3	66
LM 1.10-6055-1-275	720	60-90		5,5	75
LM 1.10-6075-1-300	940	90-150		7,5	150
LM 1.10-6110-1-350	1460	150-200		11	182

(1) Theoretical flow.

(2) Tank volume recommended to keep the product homogeneous.



I Dimensions LR

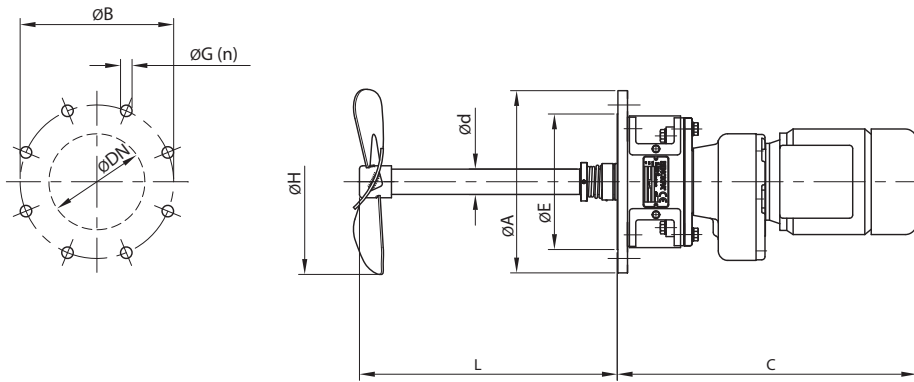

Type	Flange				Agitator shaft		H	C <sub>max</sub>	
	ØDN	ØA	ØB	ØE	ØG (n)	Ød			L
LR 1.10-20005-1-325	150	285	240	212	18 (8)	40	400	325	468
LR 1.10-20007-1-400	150	285	240	212	18 (8)	40	400	400	468
LR 1.10-20015-1-500	150	285	240	212	18 (8)	40	400	500	510
LR 1.10-20030-1-600	200	340	295	259	23 (8)	50	500	600	570
LR 1.10-20040-1-650	250	395	350	312	23 (12)	60	500	650	710

I Dimensions LM

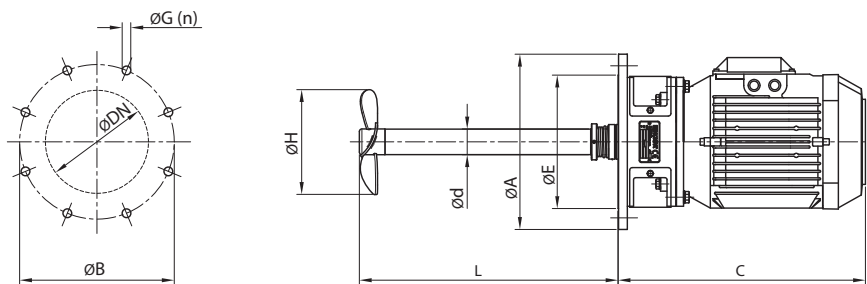

Type	Flange				Agitator shaft		H	C <sub>max</sub>	
	ØDN	ØA	ØB	ØE	ØG (n)	Ød			L
LM 1.10-4015-1-175	150	285	240	212	18 (8)	40	400	175	375
LM 1.10-4030-1-200	150	285	240	212	18 (8)	40	500	200	405
LM 1.10-4055-1-225	200	340	295	259	23 (8)	50	500	225	500
LM 1.10-4075-1-250	200	340	295	259	23 (8)	50	500	250	500
LM 1.10-4110-1-275	250	395	350	312	23 (12)	60	600	275	695
LM 1.10-6011-1-200	150	285	240	212	18 (8)	40	400	200	375
LM 1.10-6022-1-225	150	285	240	212	18 (8)	40	500	225	425
LM 1.10-6030-1-250	200	340	295	259	23 (8)	50	500	250	500
LM 1.10-6055-1-275	200	340	395	259	23 (8)	50	500	275	500
LM 1.10-6075-1-300	250	395	350	312	23 (12)	60	600	300	695
LM 1.10-6110-1-350	250	395	350	312	23 (12)	60	600	350	695

