

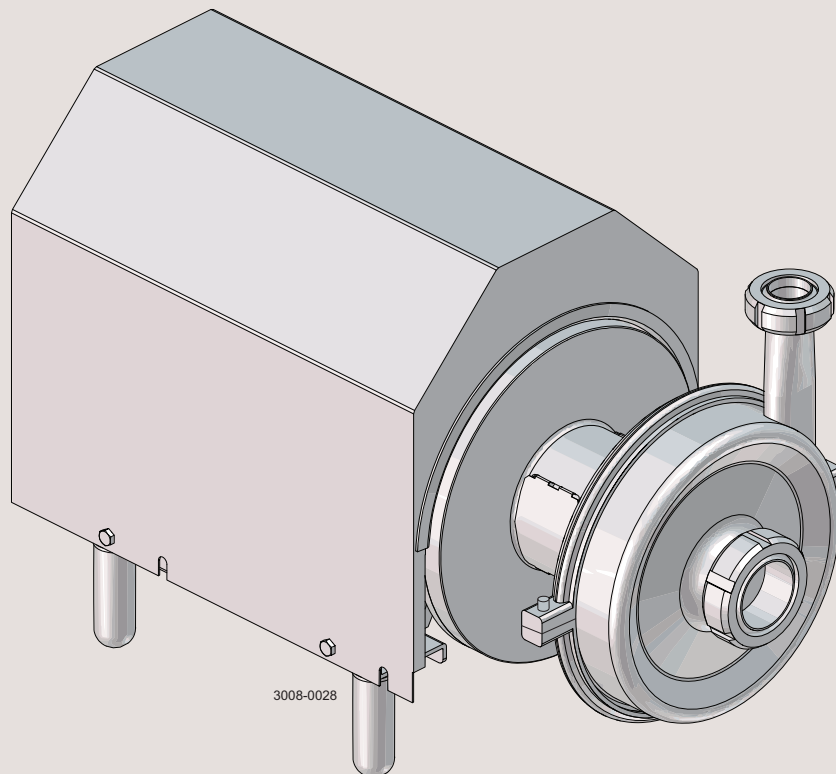

# Instruction Manual

## SolidC Pump



100002858-EN7

2016-10

Original manual



The information herein is correct at the time of issue but may be subject to change without prior notice

<b>1. EC Declaration of Conformity</b> .....	<b>4</b>
<b>2. Safety</b> .....	<b>5</b>
2.1. Important information .....	5
2.2. Warning signs .....	5
2.3. Safety precautions .....	6
<b>3. Installation</b> .....	<b>8</b>
3.1. Unpacking/delivery .....	8
3.2. Installation .....	9
3.3. Pre-use check .....	10
3.4. Recycling information .....	10
<b>4. Operation</b> .....	<b>11</b>
4.1. Operation/Control .....	11
4.2. Trouble shooting .....	13
4.3. Recommended cleaning .....	14
<b>5. Maintenance</b> .....	<b>15</b>
5.1. General maintenance .....	15
5.2. Cleaning Procedure .....	16
5.3. Dismantling of pump/shaft seals .....	17
5.4. Assembly of pump/single shaft seal .....	19
5.5. Assembly of pump/flushed shaft seal .....	21
5.6. Adjustment of shaft .....	24
<b>6. Technical data</b> .....	<b>25</b>
6.1. Technical data .....	25
6.2. Relubrication intervals .....	26
6.3. Torque Specifications .....	26
6.4. Weight (kg) .....	26
6.5. Noise emission .....	27
<b>7. Parts list and service kits</b> .....	<b>28</b>
7.1. Drawing .....	28
7.2. SolidC - Wet end .....	30
7.3. SolidC - Motor-dependent parts .....	32
7.4. SolidC - Shaft seal .....	34

# 1 EC Declaration of Conformity

Revision of Declaration of Conformity 2009-12-29

The Designated Company

Alfa Laval Kolding A/S

Company Name

Albuen 31, DK-6000 Kolding, Denmark

Address

+45 79 32 22 00

Phone No.

hereby declare that

Pump

Designation

SolidC-1, SolidC-2, SolidC-3, SolidC-4

Type

From serial number 10.000 to 1.000.000

is in conformity with the following directive with amendments:

- Machinery Directive 2006/42/EC

The person authorised to compile the technical file is the signer of this document

Global Product Quality Manager  
Pump, Valves, Fittings and Tank Equipment

Title

Lars Kruse Andersen

Name

Kolding  
Place

2013-12-03  
Date

  
Signature



---

*Unsafe practices and other important information are emphasised in this manual.  
Warnings are emphasised by means of special signs.  
Always read the manual before using the pump!*

---

### 2.1 Important information

---

#### **WARNING**

Indicates that special procedures must be followed to avoid serious personal injury.

#### **CAUTION**

Indicates that special procedures must be followed to avoid damage to the pump.

#### **NOTE**

Indicates important information to simplify or clarify procedures.

---

### 2.2 Warning signs

---

General warning:



Dangerous electrical voltage:



Caustic agents:



## 2 Safety

---

*Unsafe practices and other important information are emphasised in this manual.*

*Warnings are emphasised by means of special signs.*

***Always read the manual before using the pump!***

---

### 2.3 Safety precautions

---

#### Installation:

**Always** read the technical data thoroughly. (See chapter 6 Technical data)

**Always** use a lifting crane when handling the pump.

**Never** start in the wrong direction of rotation with liquid in the pump.

**Always** have the pump electrically connected by authorised personnel. (See the motor instruction)



#### Operation:

**Always** read the technical data thoroughly. (See chapter 6 Technical data)

**Never** touch the pump or the pipelines when pumping hot liquids or when sterilising.

**Never** run the pump with both the suction side and the pressure side blocked.

**Never** run the pump when partially installed or not completely assembled

**Necessary** precautions must be taken if leakage occurs as this can lead to hazardous situations



**Always** handle lye and acid with great care.

**Never** use the pump for products not mentioned in the Alfa Laval pump selection program.

The Alfa Laval pump selection program can be acquired from your local Alfa Laval sales company.

---

#### Maintenance:

**Always** read the technical data thoroughly. (See chapter 6 Technical data)

**Never** service the pump when it is hot.

**Never** service the pump if pressurised.

**Always** use Alfa Laval genuine spare parts.

#### Motors with grease nipples:

Remember lubrication must be in accordance with the information plate/label on the motor.



**Always** disconnect the power supply when servicing the pump.

---

#### Transportation:

##### Transportation of the pump or the pump unit:

**Never** lift or elevate in any way other than described in this manual

**Always** drain the pump head and accessories of any liquid

**Always** ensure that no leakage of lubricants can occur

**Always** transport the pump in its upright position

**Always** ensure that the unit is securely fixed during transportation

**Always** use original packaging or similar during transportation

*Unsafe practices and other important information are emphasised in this manual.*

*Warnings are emphasised by means of special signs.*

***Always read the manual before using the pump!***

---

---

## 3 Installation

---

### 3.1 Unpacking/delivery

---

#### Step 1

Always use a lifting crane when handling the pump  
(See chapter 6 Technical data).

#### CAUTION

Alfa Laval cannot be held responsible for incorrect unpacking.

#### Check the delivery for

1. Complete pump.
2. Delivery note.
3. Motor instructions.
4. Test certificate, IF ORDERED!!

#### Step 2

Remove any packing materials from the inlet and the outlet.  
Avoid damaging the inlet and the outlet.  
Avoid damaging the connections for flushing liquid, if supplied.

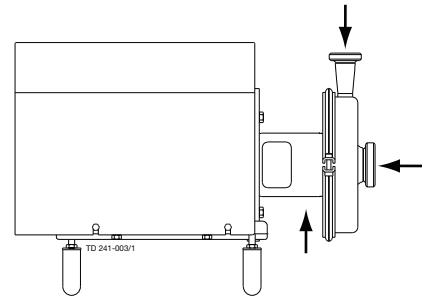

#### Step 3

Inspect the pump for visible transport damage.

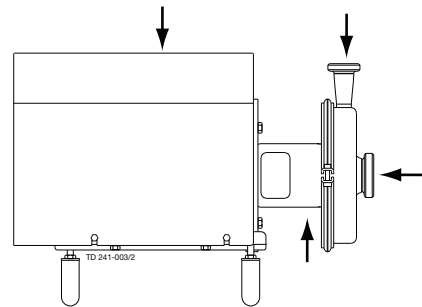

#### Step 4

Always remove the shroud, if fitted, before lifting the pump.

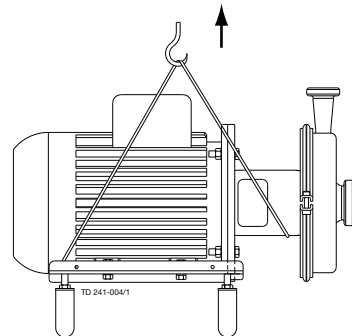



Study the instructions carefully and pay special attention to the warnings! Always check the pump before operation.

- See pre-use check in section 3.3 Pre-use check, page 10

The large pump sizes are very heavy. Alfa Laval therefore recommends the use of a lifting crane when handling the pump.

#### 3.2 Installation

##### Step 1



**Always** read the technical data thoroughly.  
(See chapter 6 Technical data)



**Always** use a lifting crane when handling the pump.

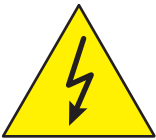

**Always** have the pump electrically connected by authorised personnel. (see the motor instructions).

##### NOTE

In case of shaft seal leakage, the media will drip from the slot in the bottom of the adaptor. In case of shaft seal leakage, Alfa Laval recommends placing a drip tray underneath the slot for collecting the leakage.

##### CAUTION

Alfa Laval cannot be held responsible for incorrect installation.

##### WARNING:

Alfa Laval recommend the installation of a lockable repair breaker. If the repair breaker is to be used as an emergency stop, the colors of the repair breaker must be red and yellow.

##### CAUTION

The pump does not prevent back flow when intentionally or unintentionally stopped. If back flow can cause any hazardous situations, precautions must be taken e.g. check valve to be installed in the system preventing above described.

##### Step 2

Ensure that there is sufficient clearance around the pump (min. 0.5 m)(1.64 ft).

##### NOTE!

US pumps have no shroud

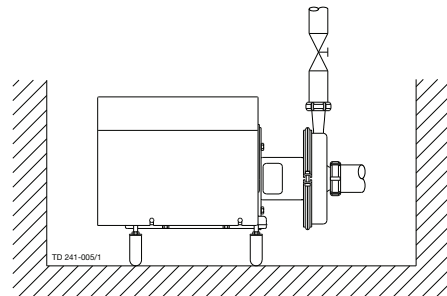

##### Step 3

Check that the flow direction is correct.

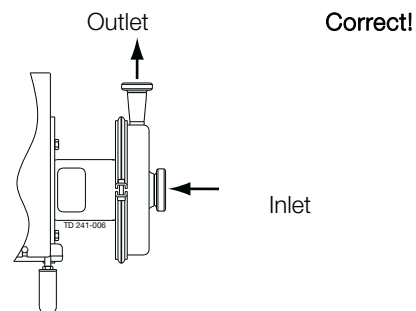

### 3 Installation

Study the instructions carefully and pay special attention to the warnings!  
SolidC comes with impeller screw as standard.  
Check the direction of rotation of the impeller before operation.  
- See the indication label on the pump.

#### Step 4

1. Ensure that the pipelines are routed correctly.
2. Ensure that the connections are tight.

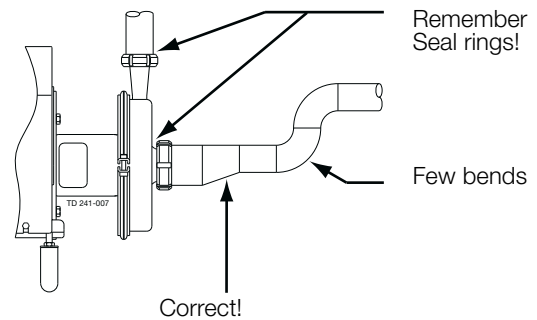

#### Step 5

Avoid stressing the pump.

Pay special attention to:

- Vibrations
- Thermal expansion of the tubes
- Excessive welding
- Overloading

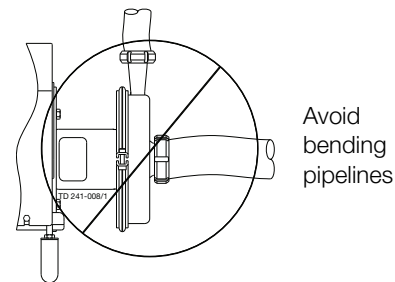

### 3.3 Pre-use check

#### Step 1



**Never** start in the wrong direction of rotation with liquid in the pump.

1. Start and stop the motor momentarily
2. Ensure that the direction of rotation of the motor fan is clockwise as viewed from the rear end of the motor.

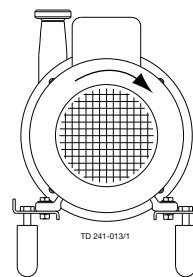

See indication label!

Correct

Rear view of motor

### 3.4 Recycling information

#### • Unpacking

- Packing material consists of wood, plastics, cardboard boxes and in some cases metal straps.
- Wood and cardboard boxes can be reused, recycled or used for energy recovery
- Plastics should be recycled or burnt at a licensed waste incineration plant
- Metal straps should be sent for material recycling

#### • Maintenance

- During maintenance, oil and wear parts in the machine are replaced
- All metal parts should be sent for material recycling
- Worn out or defective electronic parts should be sent to a licensed handler for material recycling
- Oil and all non-metal wear parts must be disposed of in accordance with local regulations

#### • Scrapping

- At end of use, the equipment must be recycled according to relevant, local regulations. Besides the equipment itself, any hazardous residues from the process liquid must be considered and dealt with in a proper manner. When in doubt, or in the absence of local regulations, please contact your local Alfa Laval sales company.

Study the instructions carefully and pay special attention to the warnings!

### 4.1 Operation/Control

#### Step 1



**Always** read the technical data thoroughly. (See chapter 6 Technical data)

#### CAUTION

Alfa Laval cannot be held responsible for incorrect operation/control.

#### Step 2



**Never** touch the pump or the pipelines when pumping hot liquids or when sterilising.

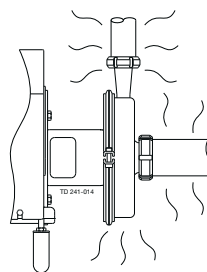

**Danger of burns!**



#### Step 3



**Never** run the pump with both the suction side and the pressure side blocked.

**Danger of explosion!**

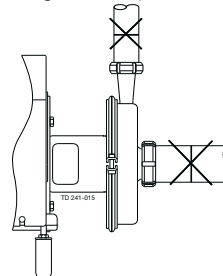

**See the warning label!**

#### Step 4

#### CAUTION

The shaft seal must not run dry.

#### CAUTION

**Never** throttle the inlet side.

**Do not allow to run dry**

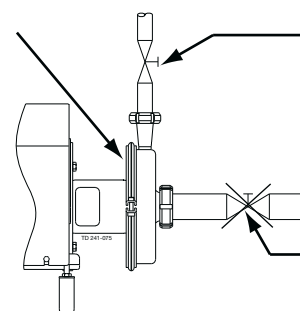

Correct!

Wrong

## 4 Operation

Study the instructions carefully and pay special attention to the warnings!

### Step 5

#### Flushed shaft seal:

1. Connect the inlet of the flushing liquid correctly.
2. Regulate the water supply correctly.

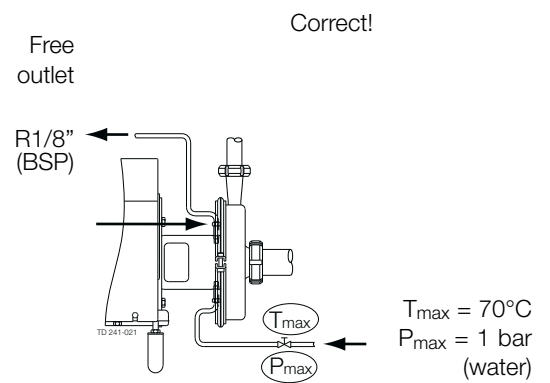

### Step 6

#### Control:

Reduce the capacity and the power consumption by means of:

- Throttling the pressure side of the pump.
- Reducing the impeller diameter.
- Reducing the speed of the motor.

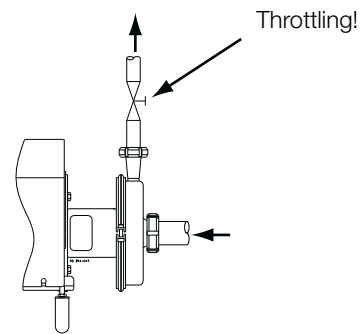

Pay attention to possible faults.  
Study the instructions carefully.

## 4.2 Trouble shooting

### NOTE!

Study the maintenance instructions carefully before replacing worn parts.

Problem	Cause/result	Remedy
Overloaded motor	<ul style="list-style-type: none"> <li>- Pumping of viscous liquids</li> <li>- Pumping of high density liquids</li> <li>- Low outlet pressure (counter pressure)</li> <li>- Lamination of precipitates from the liquid</li> </ul>	<ul style="list-style-type: none"> <li>- Larger motor or smaller impeller</li> <li>- Higher counter pressure (throttling)</li> <li>- Frequent cleaning</li> </ul>
Cavitation: <ul style="list-style-type: none"> <li>- Damage</li> <li>- Pressure reduction (sometimes to zero)</li> <li>- Increasing of the noise level</li> </ul>	<ul style="list-style-type: none"> <li>- Low inlet pressure</li> <li>- High liquid temperature</li> </ul>	<ul style="list-style-type: none"> <li>- Increase the inlet pressure</li> <li>- Reduce the liquid temperature</li> <li>- Reduce the pressure drop before the pump</li> <li>- Reduce speed</li> </ul>
Leaking shaft seal	<ul style="list-style-type: none"> <li>- Dry run</li> <li>- Incorrect rubber grade</li> <li>- Abrasive particles in the liquid</li> </ul>	Replace: All wearing parts If necessary: <ul style="list-style-type: none"> <li>- Change rubber grade</li> <li>- Select stationary and rotating seal ring in silicon carbide/silicon carbide</li> </ul>
Leaking O-ring seals	Incorrect rubber grade	Change rubber grade

## 4 Operation

The pump is designed for cleaning in place (CIP). CIP = Cleaning In Place.  
Study the instructions carefully and pay special attention to the warnings!  
NaOH = Caustic Soda.  
HNO<sub>3</sub> = Nitric acid.

### 4.3 Recommended cleaning

#### Step 1



**Always** handle lye and acid with great care.

**Caustic danger!**



Always use rubber gloves!



Always use protective goggles!

#### Step 2



**Never** touch the pump or the pipelines when sterilising.

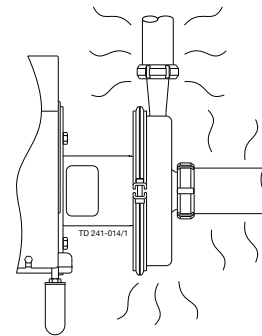

**Danger of burns!**



#### Step 3

**Examples of cleaning agents:** Use clean water, free from chlorides.

1. 1% by weight NaOH at 70°C (158°F).

1 kg (2.2 lb) NaOH	+	100 l (26.4 gal) water	= Cleaning agent.
-----------------------	---	---------------------------	-------------------

2.2 l (0.6 gal) 33%NaOH	+	100 l (26.4 gal) water	= Cleaning agent.
----------------------------	---	---------------------------	-------------------

2. 0.5% by weight HNO<sub>3</sub> at 70°C (158°F).

0.7 l (0.2 gal) 53% HNO <sub>3</sub>	+	100 l (26.4 gal) water	= Cleaning agent.
---	---	---------------------------	-------------------

1. Avoid excessive concentration of the cleaning agent  
⇒ Dose gradually!
2. Adjust the cleaning flow to the process.  
Sterilisation of milk/viscous liquids  
⇒ Increase the cleaning flow!

#### Step 4



**Always** rinse well with clean water after using a cleaning agent.

#### NOTE

The cleaning agents must be stored/disposed of in accordance with current regulations/directives.

**Always rinse!**

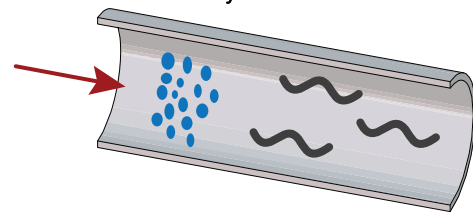

Water      Cleaning agent

3013-0153

Maintain the pump carefully. Study the instructions carefully and pay special attention to the warnings!  
 Always keep spare shaft seals and rubber seals in stock.  
 See separate motor instructions.  
 Check the pump for smooth operation after service.

### 5.1 General maintenance

#### Step 1



**Always** read the technical data thoroughly. (See chapter 6 Technical data)



**Always** disconnect the power supply when servicing the pump.

#### NOTE

All scrap must be stored/discharged in accordance with current rules/directives.

#### Step 2



**Never** service the pump when it is hot.

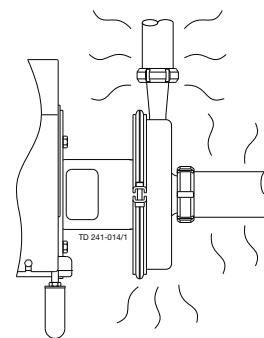

**Danger of burns!**

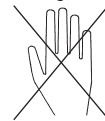

#### Step 3



**Never** service the pump with pump if pressurised.

#### CAUTION

Fit the electrical connections correctly if they have been removed from the motor during service.

#### CAUTION

Pay special attention to the warnings!

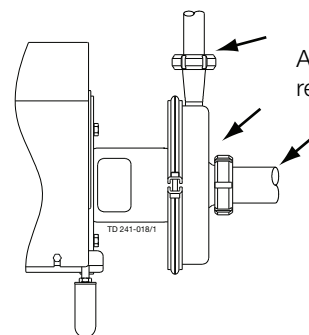

Atmospheric pressure required!

#### Step 4

##### Recommended spare parts:

Order service kits from the service kits list (see chapter 7 Parts list and service kits).

##### Ordering spare parts

Contact your local Alfa Laval sales company.

#### Note:

If the pump is supplied with FEP O-rings, Alfa Laval recommends that the casing O-ring is replaced during pump maintenance.

## 5 Maintenance

Maintain the pump carefully. Study the instructions carefully and pay special attention to the warnings!  
 Always keep spare shaft seals and rubber seals in stock.  
 See separate motor instructions.  
 Check the pump for smooth operation after service.

	Shaft seal	Rubber seals	Motor bearings
Preventive maintenance	<b>Replace after 12 months:</b> (one-shift) Complete shaft seal	Replace when replacing the shaft seal	
Maintenance after leakage (leakage normally starts slowly)	<b>Replace at the end of the day:</b> Complete shaft seal	Replace when replacing the shaft seal	
Planned maintenance	<ul style="list-style-type: none"> <li>- Regular inspection for leakage and smooth operation</li> <li>- Keep a record of the pump</li> <li>- Use the statistics for inspection planning</li> </ul> <p><b>Replace after leakage:</b> Complete shaft seal</p>	Replace when replacing the shaft seal	Yearly inspection is recommended <ul style="list-style-type: none"> <li>- Replace complete bearing if worn</li> <li>- Ensure that the bearing is axially locked (See motor instructions)</li> </ul>
Lubrication	<b>Before fitting</b> Lubricate the O-rings with silicone grease or silicone oil	<b>Before fitting</b> Silicone grease or silicone oil	The bearings are permanently lubricated

### Pre-use check

#### CAUTION!

Fit the electrical connections correctly if they have been removed from the motor during service.  
 (See pre-use check in chapter 3 Installation).

### Pay special attention to warnings!

1. Start and stop the motor momentarily
2. Ensure that the pump operates smoothly.

## 5.2 Cleaning Procedure

### Cleaning procedure for soiled impeller screw tapped hole:

1. Remove stub shaft (7) as per section 4 of the Service Manual
2. Submerge and soak stub shaft for 5 minutes in COP tank with 2% caustic wash
3. Scrub the blind tapped impeller screw hole vigorously by plunging a clean 1/2" diameter sanitary bristle pipe brush in and out of the hole for two minutes while submerged.
4. Soak Stub Shaft (7) in acid sanitiser for 5 minutes, then scrub blind tapped hole as described in step 3 above.
5. Rinse well with clean water and blow-dry blind tapped hole with clean air.
6. Swab test the inside of the tapped hole to determine cleanliness.
7. Should the swab test fail, repeat steps 2 to 6 above until swab test is passed.

Should swab testing continue to fail, or time is of the essence, install a new (spare) stub shaft (7).



Study the instructions carefully. The items refer to the parts list and service kits section.

Handle scrap correctly.

\* : Relates to the shaft seal.

### 5.3 Dismantling of pump/shaft seals

#### Step 1

Remove screws, spring washers, clamps (55) and pump casing (29).

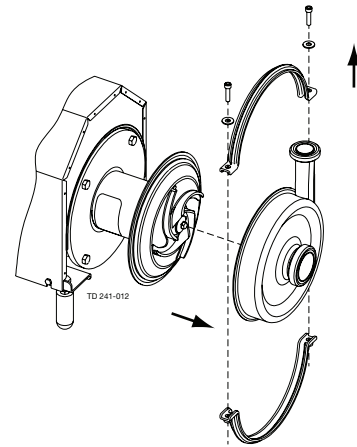

#### Step 2

##### Flushed shaft seal:

Unscrew tubes (42) using a spanner.

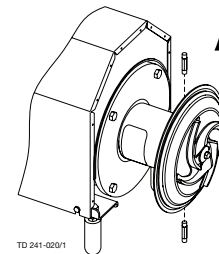

\*

#### Step 3

Remove covers (22). This is easily done by lifting out the covers, for example, using a screwdriver.

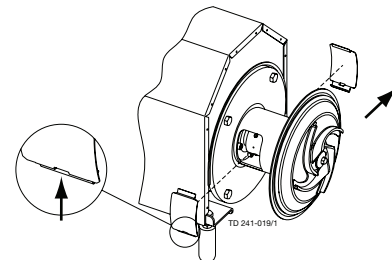

#### Step 4

1. Remove impeller screw (36).
2. Remove impeller (37). If necessary, loosen the impeller by tapping gently on the impeller vanes. The shaft can be fixed with a screwdriver in the compression ring.
3. Remove the O-ring (38) from the impeller.

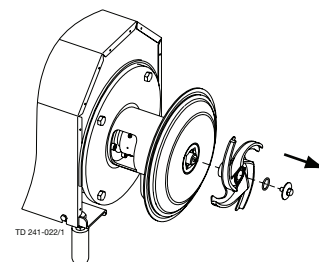

#### Step 5

1. Pull off the O-ring (26) from back plate (25).
2. Unscrew nuts (20) and remove washers (21) and the back plate.

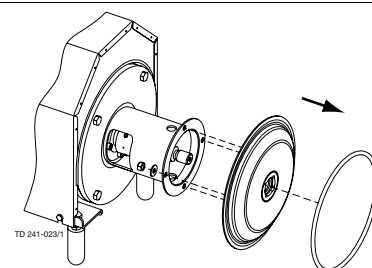

## 5 Maintenance

Study the instructions carefully. The items refer to the parts list and service kits section.

Handle scrap correctly.

\* : Relates to the shaft seal.

### Step 6

1. Remove the stationary seal ring (11).
2. Remove the O-ring (12) from stationary seal ring (11).

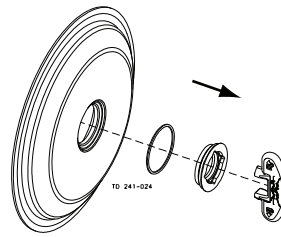

★  
Use the tool  
supplied  
left-hand  
thread

### Step 7

Flushed shaft seal:

1. Remove screws (41) and seal housing (40).
2. Pull out lip seal (43) from the seal housing.

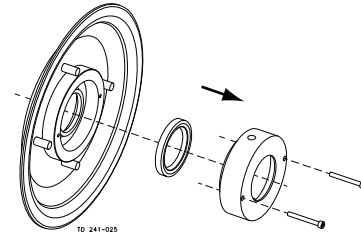

★

### Step 8

1. Remove the complete shaft seal from stub shaft (7).
2. Remove spring (13) and rotating seal ring (14) from the drive ring (10).

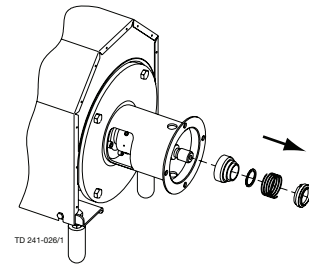

★

### Alternative dismantling of single shaft seal - Front loading

1. Complete steps 1 to 4.
2. Remove stationary seal ring.
3. Remove O-ring (12) from stationary seal ring (11).
4. Remove complete shaft seal from stub shaft.
5. Remove spring (13) and rotating seal ring (14) from the drive ring (10).

Use the tool supplied. Left-hand thread

★

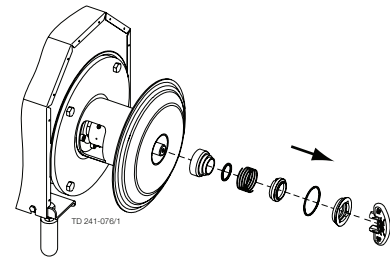

Study the instructions carefully. The items refer to the parts list and service kits section.

Handle scrap correctly.

\* : Relates to the shaft seal.

### 5.4 Assembly of pump/single shaft seal

#### Step 1

1. Remove spring (13).
2. Lubricate O-ring (15) and fit it in rotating seal ring (14).

#### NOTE!

Make sure that O-ring (15) has max. clearance from the sealing surface.

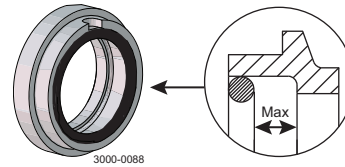

\*

#### Step 2

1. Refit spring (13) on rotating seal ring (14).
2. Fit the spring and the rotating seal ring on drive ring (10).

#### CAUTION

Ensure that the driver on the drive ring enters the notch in the rotating seal ring.

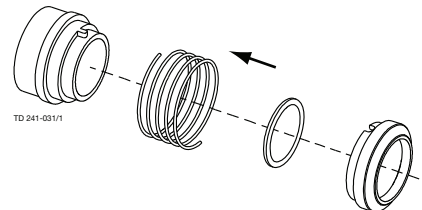

\*

#### Step 3

Fit the complete shaft seal on stub shaft (7).

#### NOTE!

Make sure that the Connex pin on the stub shaft enters the notch in drive ring (10).

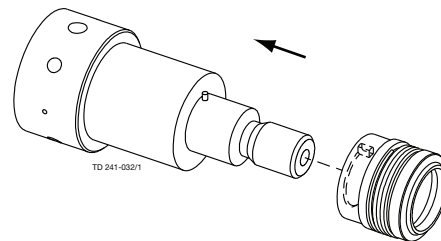

\*

#### Step 4

1. Fit O-ring (12) on stationary seal ring (11) and lubricate.
2. Screw the stationary seal ring into back plate (25).

#### CAUTION

Only tighten by hand to avoid deforming the stationary seal ring. (Max. 7Nm)

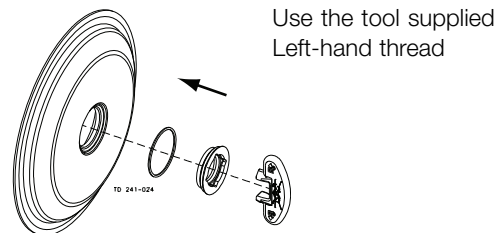

\*

#### Step 5

1. Clean the sealing surfaces with contact cleaner before fitting back plate (25).
2. Carefully guide the back plate onto adaptor (16).
3. Fit washers (21) and nuts (22).

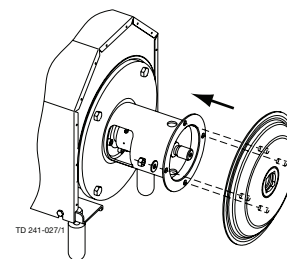

\*

#### Step 6

Lubricate O-ring (26) and slide it onto back plate (25).

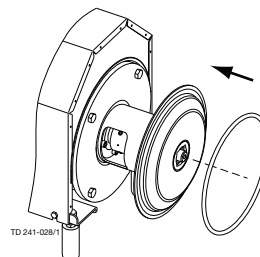

## 5 Maintenance

Study the instructions carefully. The items refer to the parts list and service kits section.

Handle scrap correctly.

\* : Relates to the shaft seal.

### Step 7

1. Lubricate O-ring (38) and fit it in impeller (37).
2. Lubricate impeller hub with silicone grease or oil.
3. Screw the impeller onto stub shaft (7).
4. Fit impeller screw (39) and tighten 20 Nm (7.4 lbf-ft).

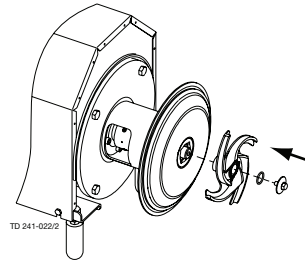

### Step 8

Fit covers (22).

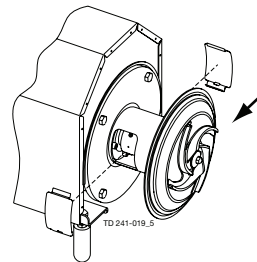

### Step 9

Fit pump casing (29), clamps, spring washer and tighten screws (55).

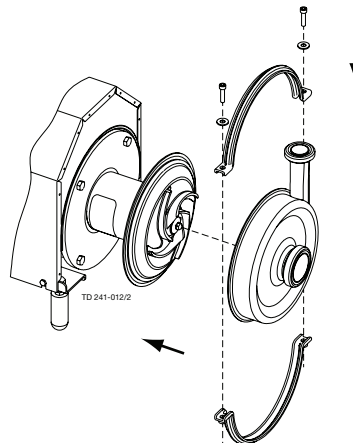

### Alternative assembly of single shaft - front loading

1. Fit rotating seal ring (14) and spring (13) on drive ring (10).
2. Fit complete shaft seal on stub shaft.
3. Fit O-ring (12) onto stationary seal ring (11).
4. Fit stationary seal ring.
5. Complete steps 4 to 1.

#### CAUTION

Ensure that the driver on the drive ring enters the notch in the rotating seal ring.

Use the tool supplied  
Left-hand thread

★

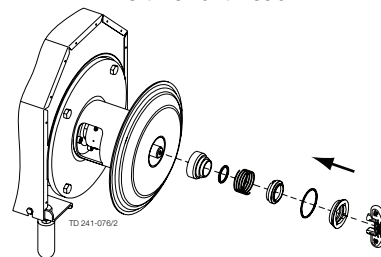

Study the instructions carefully. The items refer to the parts list and service kits section.  
Lubricate the rubber seals before fitting them.  
\*: Relates to the shaft seal.

### 5.5 Assembly of pump/flushed shaft seal

#### Step 1

1. Fit O-ring (12) on stationary seal ring (11) and lubricate.
2. Screw the stationary seal ring into back plate (25).

#### CAUTION

Only tighten by hand to avoid deforming the stationary seal ring.  
(Max 7Nm)

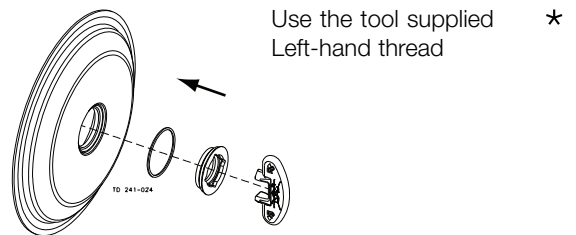

#### Step 2

#### Flushed shaft seal:

1. Fit lip seal (43) in seal housing (40).
2. Lubricate O-ring (44) and slide onto the seal housing (40).
3. Fit the seal housing on back plate (25) and tighten screws (41).

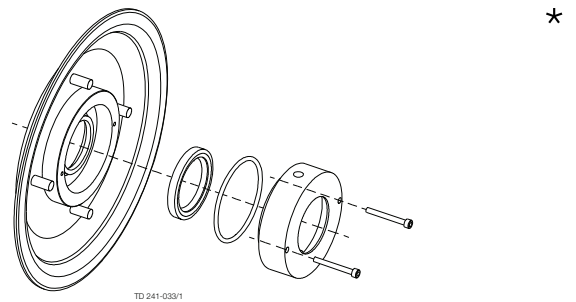

#### Step 3

1. Remove spring (13).
2. Lubricate O-ring (15) and fit it in rotating seal ring (14).

#### NOTE!

Make sure that O-ring (15) has max. clearance from the sealing surface.

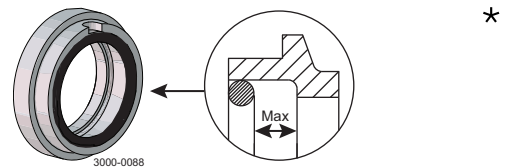

#### Step 4

1. Lubricate O-ring (45) and fit it in drive ring (10).
2. Fit spring (13) and rotating seal ring (14) on the drive ring.

#### CAUTION

Ensure that the driver on the drive ring enters the notch in the rotating seal ring.

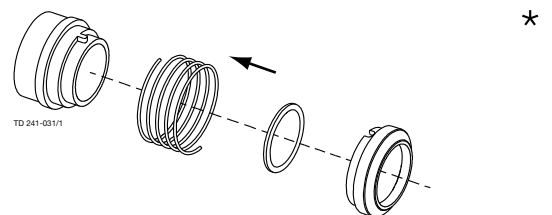

#### Step 5

Fit complete shaft seal on stub shaft (7) so that Connex pin on the stub shaft enters the notch in drive ring (10).

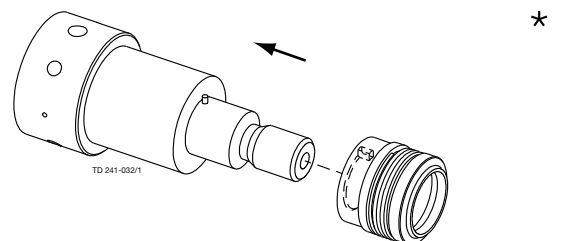

## 5 Maintenance

Study the instructions carefully. The items refer to the parts list and service kits section.

Lubricate the rubber seals before fitting them.

\* : Relates to the shaft seal.

### Step 6

1. Carefully guide back plate (25) onto adaptor (16).
2. Fit washers (21) and tighten nuts (20).

#### Note:

Make sure that holes in the seal housing are in a vertical position

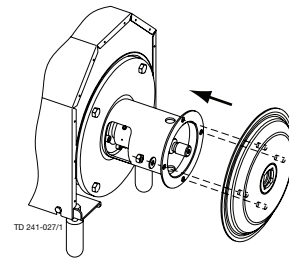

### Step 7

Lubricate O-ring (26) and slide it onto back plate (25).

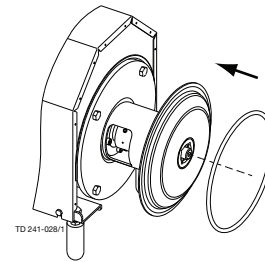

### Step 8

1. Lubricate O-ring (38) and fit it in impeller (37).
2. Lubricate the impeller hub with silicone grease or oil.
3. Screw impeller (37) onto stub shaft (7).
4. Fit impeller screw (39) and tighten to 20 Nm (7.4 lbf-ft).

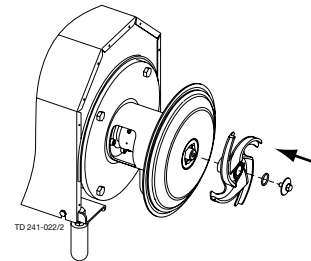

### Step 9

1. Screw tubes (42) into seal housing (40).
2. Tighten with a spanner.

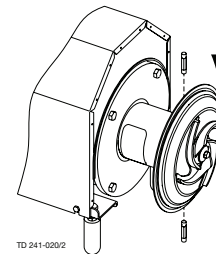

\*

### Step 10

Fit covers.

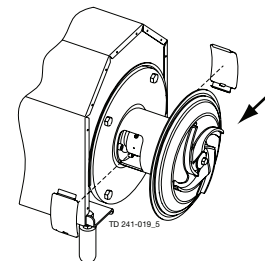

---

Study the instructions carefully. The items refer to the parts list and service kits section.  
Lubricate the rubber seals before fitting them.  
\* : Relates to the shaft seal.

---

### Step 11

Fit pump casing (29), clamps, spring washers and tighten screws (55).

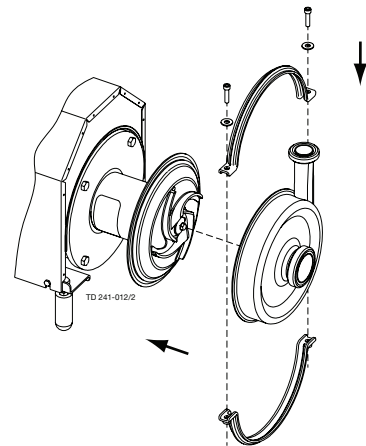

## 5 Maintenance

Study the instructions carefully. The items refer to the parts list and service kits section.

Lubricate the rubber seals before fitting them.

\* : Relates to the shaft seal.

### 5.6 Adjustment of shaft

#### Step 1

1. Loosen screws (61).
2. Pull off stub shaft (7).

#### NOTE

Always use Alfa Laval genuine parts and ensure screws do not protrude from shaft.

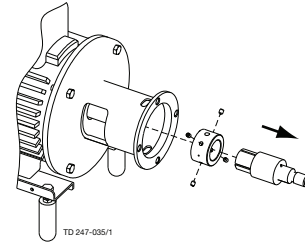

#### Step 2

1. Push stub shaft (7) onto the motor shaft.
2. Check that the clearance between the end of the stub shaft and the motor flange is 10-20 mm (0.4-0.8").

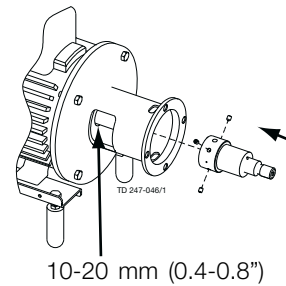

#### Step 3

1. Tighten screws (61) lightly and evenly.
2. Ensure that stub shaft (7) can be moved on the motor shaft.

#### Step 4

Fit back plate (25), washers (20) and nuts (21) and tighten.

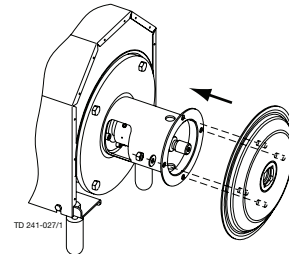

#### Step 5

1. Fit impeller (37) on stub shaft (7).
2. Ensure that the clearance between the impeller and back plate (25) is correct by using the tool supplied ((1 mm). 0.039")

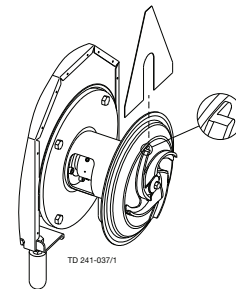

#### Step 6

Tighten screws (61) evenly to 18 Nm (13.3 lbf-ft).

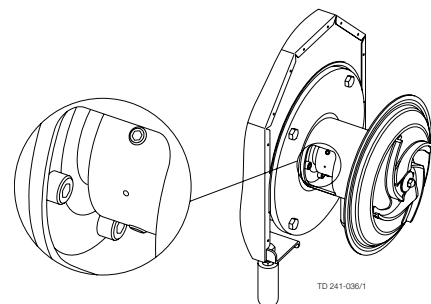



*It is important to observe the technical data during installation, operation and maintenance.  
Inform personnel about the technical data.*

### 6.1 Technical data

The SolidC pump is designed for standard duty applications, like pumping CIP (Cleaning in Place) solutions, utilities, water (processing, hydrating, cooling), washing machines, simple transport duty within working range. SolidC is suitable for use in the food, dairy, beverage, personal care, pharmaceutical, light chemical and water industries.

The SolidC is available in the following sizes SolidC-1, SolidC-2, SolidC-3 and SolidC-4.

Data	
Max. inlet pressure	400 kPa (4 bar)
Temperature range	-10°C to +120°C (EPDM)
Max. speed:	4000 rpm
Materials	
Product wetted steel parts	AISI 316L
Other steel parts	Stainless steel
Finish	Semi-bright
Product wetted seals	EPDM (standard)
Other O-rings	EPDM (standard)
Alternative seals	Nitrile (NBR), fluorinated rubber (FPM) and FEP.
Shaft seal	
Seal types	External single or flushed
Max. temperature flush media	70°C
Max. water pressure (flushed seal)	Normally atmospheric (max. 1 bar) (145 psi)
Water consumption (flushed seal)	0.25 - 0.5 l/min. (0.07 - 0.13 gpm)
Material, stationary seal ring (ROW)	Acid-resistant steel with sealing surface of silicon carbide
Material, rotating seal ring	Carbon (standard) or silicon carbide
Material, O-rings	EPDM (standard)
Alternative material, O-rings	Nitrile (NBR), fluorinated rubber (FPM) and FEP
Motor	
Foot-flanged motor according to IEC metric standard 2 poles = 3000/3600 rpm. at 50/60 Hz IP55, insulation class F	
Motor sizes (Hp), 60 Hz	1.0 - 30 Hp
Motor sizes (kW), 50 Hz	1.1 - 22 kW
Motor sizes (kW), 60 Hz	1.3 - 25 kW

For further information - see PD sheet.

## 6 Technical data

*It is important to observe the technical data during installation, operation and maintenance.  
Inform personnel about the technical data.*

### 6.2 Relubrication intervals

Motor bearings are permanently lubricated

### 6.3 Torque Specifications

The table below specifies the tightening torques for the screws, bolts and nuts in this pump.  
Always use the torques below if no other values are stated. This can be a matter of personal safety.

Size	Tightening torque	
	Nm	lbf-ft
M8	20	14.8
M10	40	29.5
M12	67	49.0
M14	110	81.0

### 6.4 Weight (kg)

Pump Type: SolidC, SolidC UltraPure

Size	Motor									
	90		100	112	132		160	180		180
	1.5kW	2.2kW	3kW	4kW	5.5kW	7.5kW	11kW	15kW	18.5kW	22kW
1	61	63	73	85						
2			76	87	108	120	173			
3					115	127	180	190	212	
4					117	129	179	189	211	267

Weight can vary depending of configuration. Weight is only to be seen as a reference value during handling, transporting and packaging.

*It is important to observe the technical data during installation, operation and maintenance.  
Inform personnel about the technical data.*

## 6.5 Noise emission

Pump Type	Sound pressure level (dBA)
LKH-5	60
LKH-10	69
LKH-15	72
LKH-20	70
LKH-25	74
LKH-35	71
LKH-40	75
LKH-45	70
LKH-50	75
LKH-60	77
LKH-70	88
LKH-75	79
LKH-85	86
LKH-90	75
LKH-112	70
LKH-113	69
LKH-114	68
LKH-122	75
LKH-123	77
LKH-124	80
SolidC-1	68
SolidC-2	72
SolidC-3	73
SolidC-4	72
MR-166	76
MR-185	82
MR-200	81
MR-300	82
GM	54
FM-OS	61

The above LKH noise levels are the same for LKHDPF, LKHDI, LKH UltraPure, LKH Evap, LKHHex.  
The above SolidC noise levels are the same for SolidC UltraPure.

The noise measurements have been carried out with original motor and shroud, approximately at the Best Efficiency Point (BEP) with water at ambient temperature and at 50 Hz.

Very often the noise level generated by the flow through the process system (e.g. valves, pipes, tanks etc.) is much higher than what is generated by the pump itself. Therefore it is important to consider the noise level from the total system and take the necessary precautions with regard to personal safety if required.

## 7 Parts list and service kits

The drawing shows SolidC pump, sanitary version.

### 7.1 Drawing

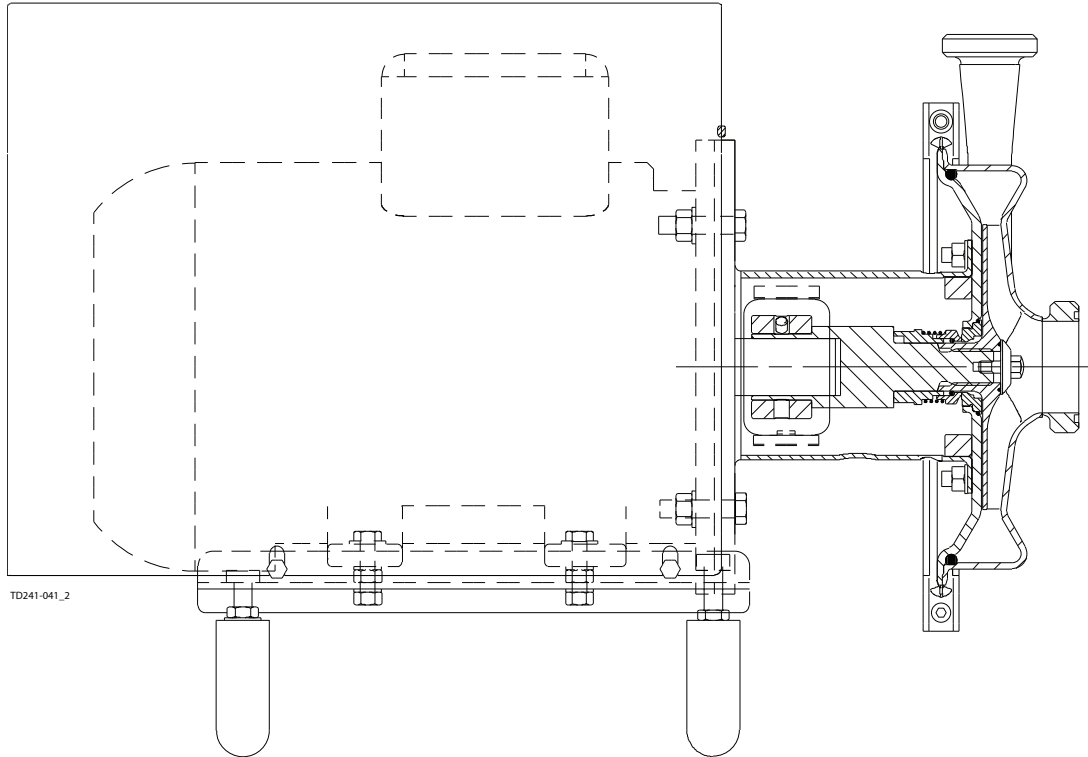

US legs are different to the ones shown. For further information, see spare parts catalogue.

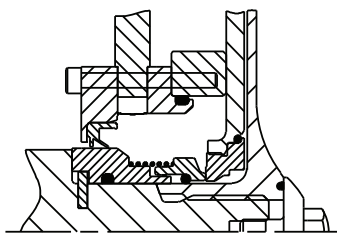

Flushed shaft seal

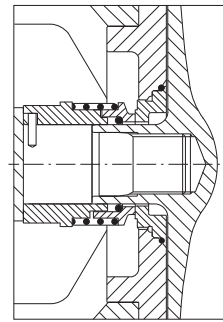

Single shaft seal



## 7 Parts list and service kits

The drawing shows SolidC pump, sanitary version.

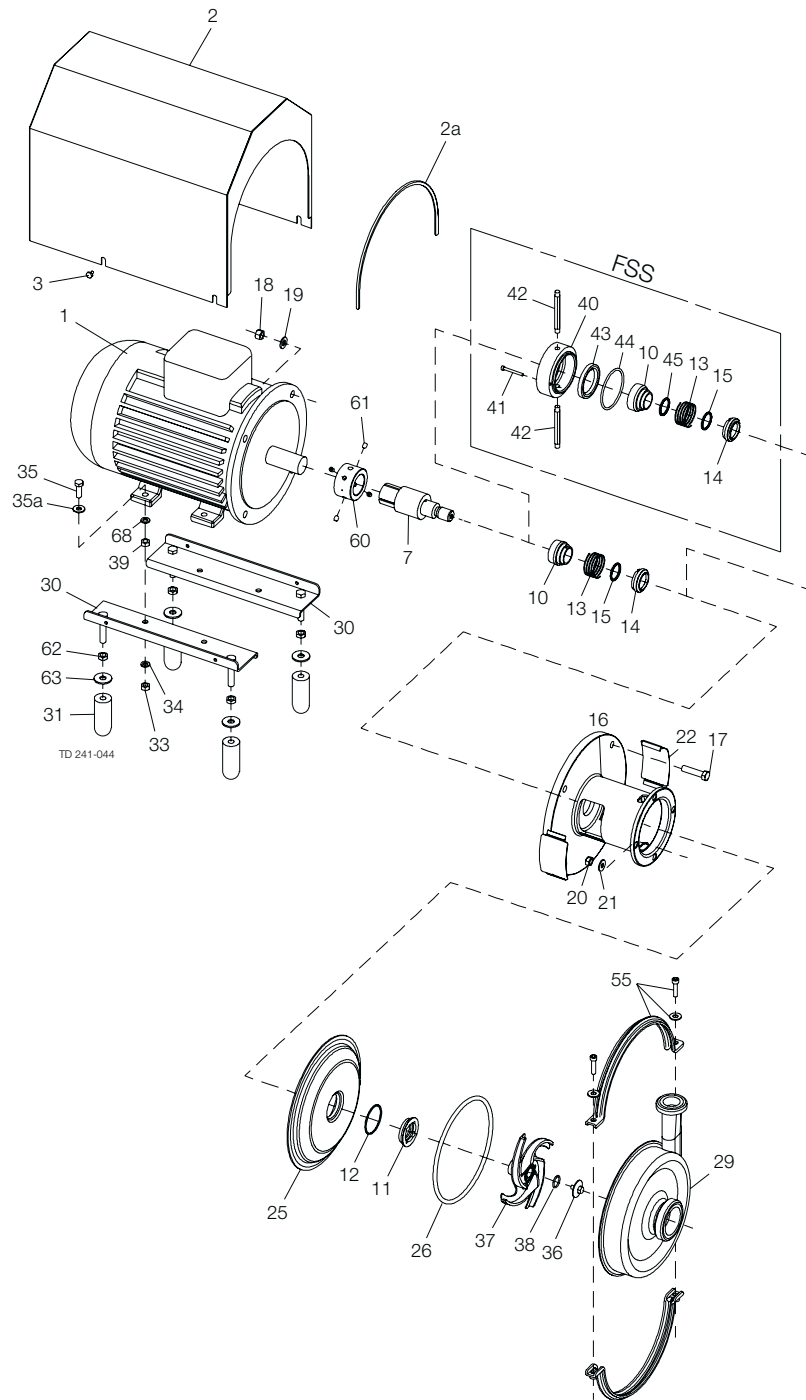

### 7.2 SolidC - Wet end



## 7 Parts list and service kits

*The drawing shows SolidC pump, sanitary version.*

### Parts list

Pos.	Qty	Denomination
20	4	Nut
21	4	Washer
25	1	Back plate
26 	1	O-ring for casing
29	1	Pump casing
36	1	Impeller screw
37	1	Impeller
38 	1	O-ring for impeller screw
55	1	Clamp set





*The drawing shows SolidC pump, sanitary version.*

### Parts list

Pos.	Qty	Denomination
1	1	Motor WEG 3000rpm
2	1	Shroud
2a	1	Edge list for shroud
3	4	Screw for shroud
7	1	Shaft
16	1	Adaptor
17	4	Screw for adaptor
18	4	Nut for adaptor
19	4	Washer for adaptor
22	2	Covers
30	2	Bracket
31	4	Legs
33	4	Nut for legs
34	4	Spring washer for legs
35	4	Screw for legs
35a	4	Washer for legs
39	4	Spacer for legs
60	1	Comp. ring
61	4	Screw for comp. ring
62	4	Nut for legs
63	4	Washer for legs
68	4	Washer for legs

## 7 Parts list and service kits

The drawing shows SolidC pump, sanitary version.

### 7.4 SolidC - Shaft seal

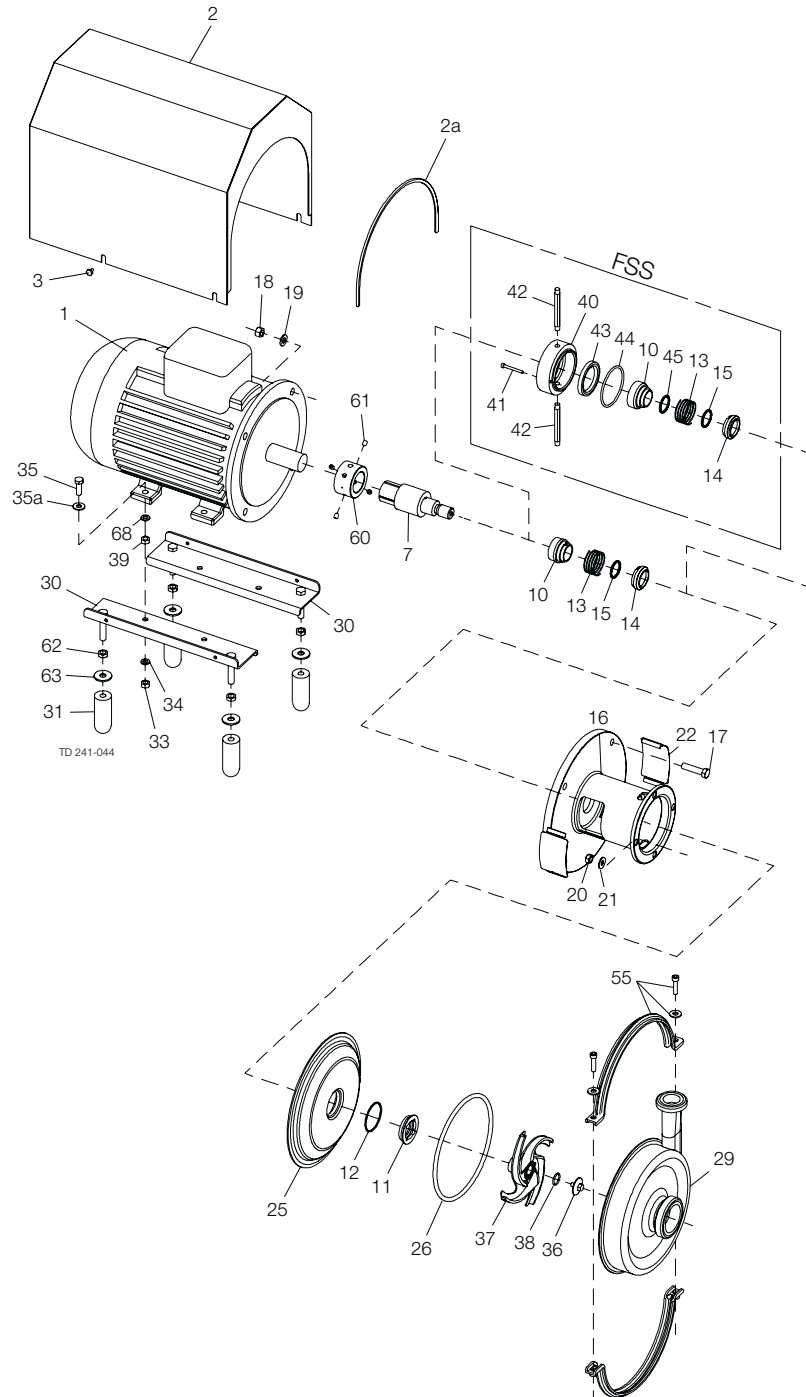

## 7 Parts list and service kits

The drawing shows SolidC pump, sanitary version.

### Parts list

Pos.	Qty	Denomination
□✦		Complete shaft seal
✦■		Complete shaft seal
○■		Complete shaft seal
★⊗		Complete shaft seal
1	1	Tool for seal
	1	Impeller gauge
10	1	Drive ring
11	1	Stationary seal ring
12	1	O-ring
13	1	Spring
14	1	Rotating seal ring
15	1	O-ring
40	1	Seal housing
41	2	Screw for seal housing
42	2	Tube
43	1	Lip seal
44	1	O-ring for seal housing
45	1	O-ring for drive ring

### Service kits

	Denomination	EPDM	NBR	FPM	FEP
<b>Service kit for single shaft seal C/SiC</b>					
□	Service kit, C/SiC (SolidC-1) .....	9611922454	9611922455	9611922456	9611922457
□	Service kit, C/SiC (SolidC-2) .....	9611922471	9611922472	9611922473	9611922474
□	Service kit, C/SiC (SolidC-3) .....	9611922487	9611922488	9611922489	9611922490
□	Service kit, C/SiC (SolidC-4) .....	9611922503	9611922504	9611922505	9611922506
<b>Service kit for single shaft seal SiC/SiC</b>					
○	Service kit, SiC/SiC (SolidC-1) .....	9611922811	9611922812	9611922813	9611922814
○	Service kit, SiC/SiC (SolidC-2) .....	9611922819	9611922820	9611922821	9611922822
○	Service kit, SiC/SiC (SolidC-3) .....	9611922827	9611922828	9611922829	9611922830
○	Service kit, SiC/SiC (SolidC-4) .....	9611922835	9611922836	9611922837	9611922838
<b>Service kit for flushed shaft seal C/SiC</b>					
◆	Service kit, C/SiC (SolidC-1) .....	9611922462	9611922463	9611922464	9611922465
◆	Service kit, C/SiC (SolidC-2) .....	9611922479	9611922480	9611922481	9611922482
◆	Service kit, C/SiC (SolidC-3) .....	9611922495	9611922496	9611922497	9611922498
◆	Service kit, C/SiC (SolidC-4) .....	9611922511	9611922512	9611922513	9611922514
<b>Service kit for flushed shaft seal SiC/SiC</b>					
*	Service kit, SiC/SiC (SolidC-1) .....	9611922815	9611922816	9611922817	9611922818
*	Service kit, SiC/SiC (SolidC-2) .....	9611922823	9611922824	9611922825	9611922826
*	Service kit, SiC/SiC (SolidC-3) .....	9611922831	9611922832	9611922833	9611922834
*	Service kit, SiC/SiC (SolidC-4) .....	9611922839	9611922840	9611922841	9611922842





**How to contact Alfa Laval**

Contact details for all countries are continually updated on our website.

Please visit [www.alfalaval.com](http://www.alfalaval.com) to access the information directly.

© Alfa Laval Corporate AB

This document and its contents is owned by Alfa Laval Corporate AB and protected by laws governing intellectual property and thereto related rights. It is the responsibility of the user of this document to comply with all applicable intellectual property laws. Without limiting any rights related to this document, no part of this document may be copied, reproduced or transmitted in any form or by any means (electronic, mechanical, photocopying, recording, or otherwise), or for any purpose, without the expressed permission of Alfa Laval Corporate AB. Alfa Laval Corporate AB will enforce its rights related to this document to the fullest extent of the law, including the seeking of criminal prosecution.