



# Alfa Laval Unique DV-ST UltraPure diaphragm valves

Discover Alfa Laval UltraPure







# Contents

Alfa Laval DV-ST UltraPure diaphragm valves .....	4
A configuration to suit any application.....	6
Valve body options .....	8
Two-way valves .....	11
Two-way valve drainability.....	13
Kv value.....	14
T-valves .....	15
Tank outlet valves .....	16
Tandem valves.....	17
Multiport diaphragm valves.....	18
How to specify and order a multiport diaphragm valve.....	21
Diaphragms.....	23
Sealing systems .....	25
Alfa Laval Q-doc.....	26
Actuators.....	28
Sensing and control.....	31
Handles.....	32
Extending your equipment's performance.....	34
Pharma and biotech product overview.....	36
Glossary .....	38

# Alfa Laval DV-ST UltraPure diaphragm valves

Alfa Laval Unique DV-ST UltraPure diaphragm valves meet the demand for reliable, contaminant-free performance for all hygienic industries, including the pharmaceutical and biotech. Constant innovation, improvement and refinement result in fully modular, customizable, high-performance aseptic valves, backed up by thorough documentation.

## A few key features that distinguish Alfa Laval DV-ST UltraPure diaphragm valves:

### Handle

Forged valve body shown here;  
cast valve body available.

Withstands product pressures of up to 10 bar, reducing the risk of product leakage and contamination.

ATEX-compliant with handwheel options in stainless steel or composite material to meet the highest hygienic demands and high temperature applications.

A broad range of fully documented pharmaceutical-grade diaphragms, making selection safe, fast and easy.

Cure date and compound tracking provided for all diaphragm materials to safeguard maintenance and change control procedures.

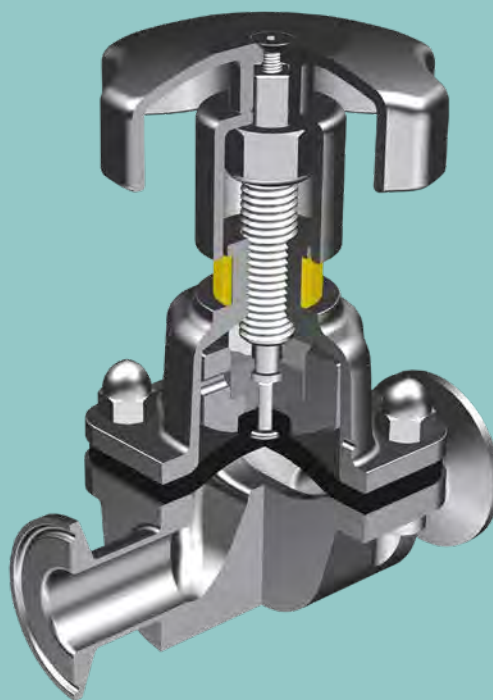

Suitable for all valves, the standard design ensures easy selection, proven reliability, and few spare parts.

All stainless-steel design for both manual and actuated valves, enabling the entire range to be autoclaved to 121°C.

EPDM rubber diaphragms rated to 150°C for continuous steam applications, providing longer product life and lower running costs.

High-grade EPDM diaphragm for steam applications, providing a single-layer design for fast leak detection in the unlikely event of diaphragm failure.

## HP actuator

Forged valve body shown here; cast valve body available.

High pressure actuator with standard Alfa Laval mushroom connections for easy mounting and uniform top units throughout the plant.

Supplied with every diaphragm valve and spare part upon delivery, Alfa Laval Q-doc can also be downloaded from our website 24/7.

Special alloy body options include Duplex, Hastelloy and AL-6XN for longer life in corrosive applications.

With Alfa Laval Q-doc, you have all quality information in a single document, ensuring easy validation, qualification and change control procedures.

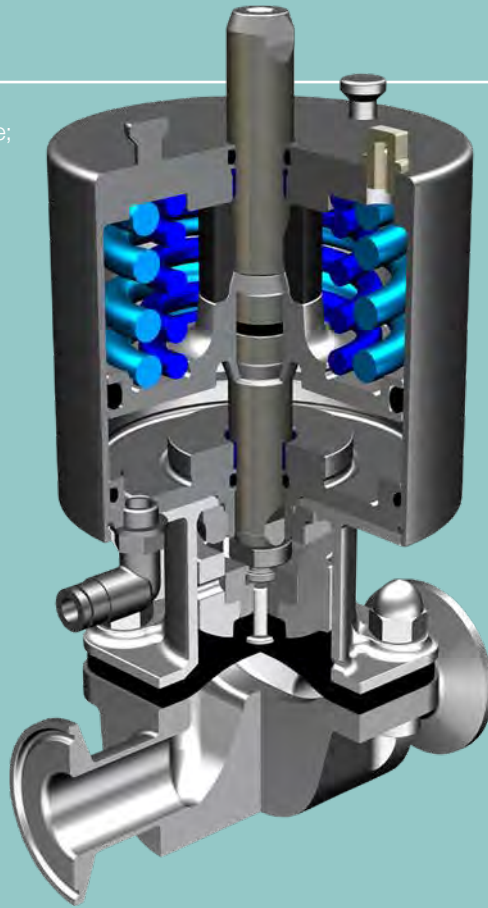

High-pressure actuators for high product pressure on both sides of the weir ( $\Delta P$  100%), reducing the risk of product leakages and contamination.

Standard ATEX-compliant actuator with five-year warranty fits all valves, ensuring easy selection and proven reliability.

Safe sealing system without metal sealing ridge that minimizes stress, reducing risk of diaphragm failure and contamination.

## SL actuator

Cast valve body shown here; forged and block bodies available.

Slim actuator provides space for installation with correct drain angles and for building compact systems.

Simple indication unit with minimum built-in dimensions provides safe feedback.

Optimized flow valve body geometry provides compact design for small built-in dimensions.

A valve body with unique flow geometry that provides a near-linear flow curve for more accurate flow control.

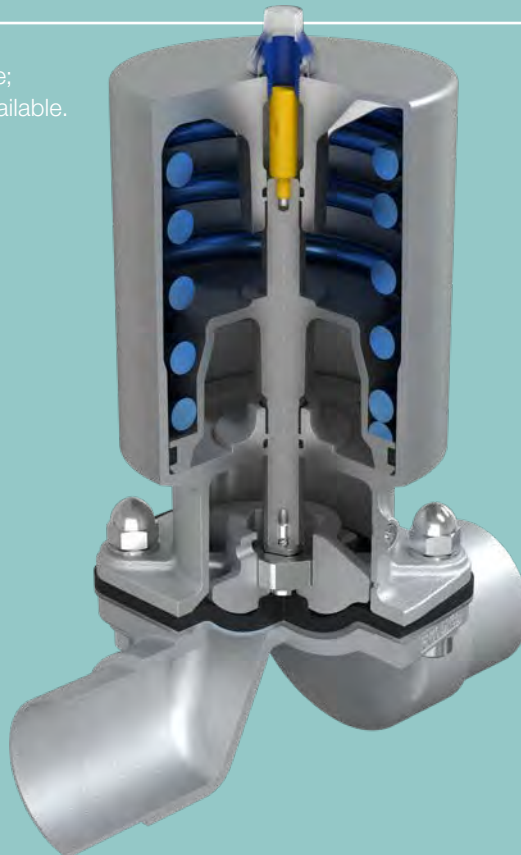

Standard ATEX-compliant, all-stainless steel actuator is robust, long lasting and autoclavable.

Lightweight actuator minimizes the need for valve and piping support.

Cast valve body options for manual and actuated valves polished to 0.4 Ra EP for a high-quality and cost-efficient solution.

Optimized performance without sharp edges or areas with low flow secures fast and easy valve cleaning.

# A configuration to suit any application

Design your own Alfa Laval Unique DV-ST UltraPure diaphragm valve. Modular means you choose the control unit, actuator or handle, diaphragm and valve body that optimize your processes.



Full modularity and enhanced compatibility make the Alfa Laval Unique DV-ST UltraPure diaphragm valves perfect for all hygienic industries.



# Valve body options

To suit the most demanding applications, Alfa Laval Unique DV-ST UltraPure valve bodies are available in cast, forged, and block types. For critical applications with corrosive media, there are special alloy options for block types including Hastelloy, Duplex, and AL-6XN materials.

## Valve bodies



Type	Cast	Forged	Block
Size	6.35–76.2 mm (¼–3")	6.35–76.2 mm (¼–3")	6.35–101.6 mm (¼–4")
Alloy	CF3M (316L)	1.4435 (316L)	1.4404 (316L)
Special alloy	N/A	N/A	1.4435, Duplex, Hastelloy, AL6XN
Delta ferrite	<5.0%	<0.5%	<0.5%
Sulphur	0.005%–0.017%	0.005–0.017%	0.005–0.017%
Internal surface finish	0.51Ra mechanical (SF1) and 0.38Ra electropolished (SF4)	0.51Ra mechanical (SF1) and 0.38Ra electropolished (SF4)	0.51Ra mechanical (SF1) and 0.38Ra electropolished (SF4)
External surface finish	Blasted (other finish available on request)	Blasted (other finish available on request)	Machined surface (other finish available on request)
Connections	Buttweld, clamp	Buttweld, clamp	Buttweld, clamp
Standard dimension	ASME BPE, ISO 2037	ASME BPE, ISO 2037, DIN 11850, ISO 1127	ASME BPE, ISO 2037, DIN 11850, ISO 1127

### Cast

Alfa Laval Unique DV-ST UltraPure cast valve bodies are manufactured from high-quality investment castings. The manufacturing process starts with a wax shell, which is coated in ceramic material. The shell is then heated in a kiln where the wax melts away, leaving the final mould for molten metal to be cast. It is then cooled, machined, and polished into the Unique DV-ST UltraPure diaphragm valve body. Stringent quality checks and advanced casting procedures ensure porosity-free valve bodies.

### Forged

Unique DV-ST UltraPure forged valve bodies are manufactured from stainless steel ingots. An ingot is compressed using forging tools under high pressure and high temperature to form the diaphragm valve body shape. It is then machined and polished into the finished product. The forging process ensures a homogenous, high-density, porosity-free valve body.

### Block

Unique DV-ST UltraPure block valves are manufactured from bar stock. To create the valve body, various machining processes are used to produce many different sizes and shapes. Using bar stock enables the use of high-performance materials such as AL-6XN and Hastelloy alloys. Block valves offer a homogenous, high-density, porosity-free material.

Enhance your processes with the Alfa Laval Cast Optimized Performance (OP) valve body. Using advanced computational fluid dynamics (CFD) analysis, Alfa Laval was able to optimize performance. A near-linear flow curve also makes the Cast OP valve body suitable for use as a flow control valve.

Optimized flow geometry secures uniform flow across the entire surface, eliminating low-flow areas and facilitating safe, easy valve cleaning. The Cast OP valve body is also smaller, making it easier to build more compact systems with minimized deadleg.

CFD flow analysis.

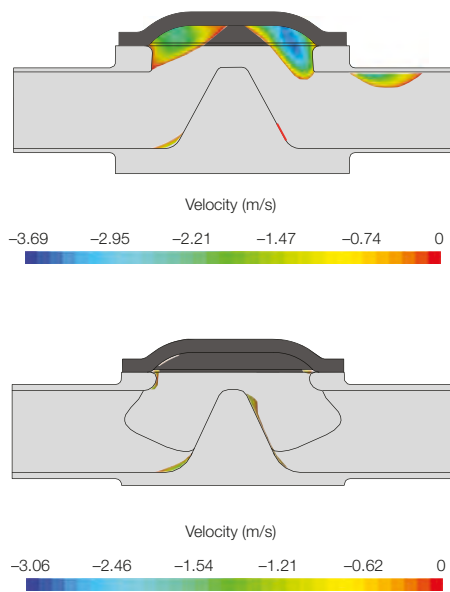



Unique DV-ST UltraPure two-way diaphragm valves are available in forged, cast or block types.

# Two-way valves

Available as forged, cast or block types, Alfa Laval Unique DV-ST UltraPure two-way diaphragm valves come in sizes from ¼" to 4" (DN 8 to DN 100) and are fully compatible with all other components in the Unique DV-ST UltraPure range.

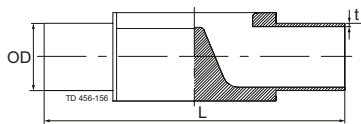

## Weld ends (mm)

Port size		Length	ASME BPE	ISO 2037	DIN11850 <sup>1</sup> (Series A)	ISO1127 <sup>1</sup> (Series B)
DN	Inch	L	OD × t	OD × t	OD × t	OD × t
8	¼"	89	6.35 × 0.89	12.00 × 1.00	10.00 × 1.0	13.50 × 1.60
10	⅜"	89	9.53 × 0.89	12.70 × 1.00	13.00 × 1.50	17.20 × 1.60
15	½"	89	12.70 × 1.65	–	–	–
15	½"	110	12.70 × 1.65	17.20 × 1.00	19.00 × 1.50	21.30 × 1.60
20	¾"	119	19.05 × 1.65	21.30 × 1.00	23.00 × 1.50	26.90 × 1.60
25	1"	129	25.40 × 1.65	25.00 × 1.20	29.00 × 1.50	33.70 × 2.00
32	1¼"	129	–	–	35.00 × 1.50	–
32	1¼"	161	–	–	–	42.40 × 2.00
40	1½"	161	38.10 × 1.65	38.00 × 1.20	41.00 × 1.50	48.30 × 2.00
50	2"	192	50.80 × 1.65	51.00 × 1.20	53.00 × 1.50	60.30 × 2.00
65	2½"	218	63.50 × 1.65	63.50 × 1.60	70.00 × 2.00	76.10 × 2.00
80	3"	256	76.20 × 1.65	76.10 × 1.60	85.00 × 2.00	88.90 × 2.30
100	4"	218	101.60 × 2.11	101.60 × 2.00	104.00 × 2.00	114.30 × 2.30

<sup>1</sup> Forged only.

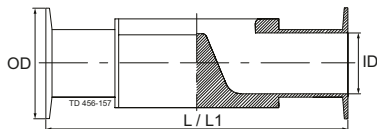

## Clamp ends (mm)

Port size		Length	Length	Clamp ASME BPE for ASME BPE		Clamp ISO 2852 for ISO 2037		Clamp DIN 32676 <sup>1</sup> for Series A/DIN		Clamp DIN 32676 <sup>1</sup> for Series B/ISO	
DN	Inch	L <sup>3</sup>	L1 <sup>2</sup>	OD	ID	OD	ID	OD	ID	OD	ID
8	¼"	89	63.5	25.00	4.57	34.00	10.00	25.00	8.00	25.00	10.3
10	⅜"	89	63.5	25.00	7.75	34.00	10.70	34.00	10.00	–	–
10	⅜"	108	–	–	–	–	–	–	–	25.00	14.0
15	½"	–	63.5	25.00	9.40	–	–	–	–	–	–
15	½"	108	89	25.00	9.40	34.00	15.20	34.00	16.00	50.50	18.1
20	¾"	118	102	25.00	15.75	34.00	19.30	34.00	20.00	50.50	23.7
25	1"	127	114	50.50	22.10	50.50	22.60	50.50	26.00	50.50	29.7
32	1¼"	127	–	–	–	–	–	50.50	32.00	–	–
32	1¼"	159	–	–	–	–	–	–	–	64.00	38.4
40	1½"	159	140	50.50	34.80	50.50	35.60	50.50	38.00	64.00	44.3
50	2"	191	159	64.00	47.50	64.00	48.60	64.00	50.00	77.50	56.3 <sup>1</sup>
65	2½"	216	194	77.50	60.20	77.50	60.30	91.00	66.00	91.00	72.1
80	3"	254	222	91.00	72.90	91.00	72.90	106.00	81.00	106.00	84.3
100	4"	305	–	118.92	97.38	119.00	97.60	119.00	100.00	119.00	109.7

<sup>1</sup> Forged only.

<sup>2</sup> ASME BPE forged valves only, short version according to ASME BPE dimension table for hygienic clamp joint: weir-style diaphragm valve.

<sup>3</sup> Standard built-in length according EN 558-1, Series 7.

Alfa Laval Unique DV-ST UltraPure dimension overview for two-way valves. Further dimensions and 3D drawings can be found in Cadenas tool at <http://alfalaval.partcommunity.com/3d-cad-models/>

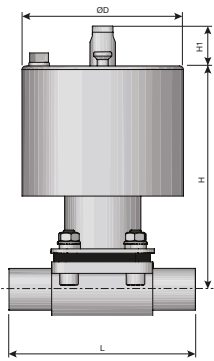

HP Forged

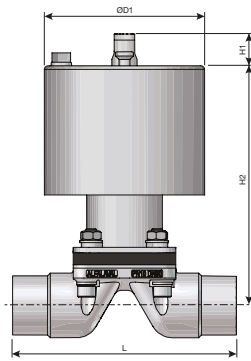

HP Cast

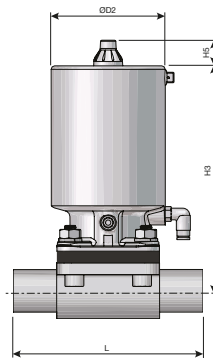

SL Forged

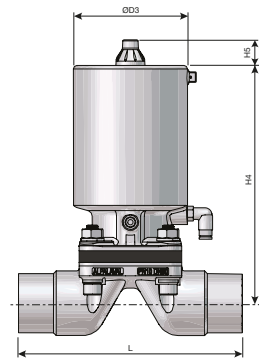

SL Cast

Size	ØD	ØD1	ØD2	ØD3	H	H1	H2	H3	H4	H5	L (weld ends)	L (clamp)	
DN	Inch	mm (in)	mm (in)	mm (in)	mm (in)	mm (in)	mm (in)	mm (in)	mm (in)	mm (in)	mm (in)	mm (in)	
8-10	¼"-¾"	54 (2.13)	54 (2.13)	49 (1.93)	49 (1.93)	109 (4.29)	19 (0.74)	110 (4.33)	94 (3.70)	94 (3.70)	22 (0.87)	89 (3.50)	89 (3.50)
15	½"	54 (2.13)	54 (2.13)	49 (1.93)	49 (1.93)	119 (4.69)	22 (0.87)	110 (4.33)	96 (3.78)	94 (3.70)	22 (0.87)	110 (4.33)	108 (4.25)
20	¾"	102 (4.00)	54 (2.13)	69 (2.72)	49 (1.93)	152 (5.98)	28 (1.09)	122 (4.80)	128 (5.04)	99 (3.90)	22 (0.87)	119 (4.69)	118 (4.65)
25*	1"	102 (4.00)	102 (4.00)	79 (3.11)	69 (2.72)	161 (6.34)	31 (1.20)	154 (6.06)	155 (6.10)	130 (5.12)	22 (0.87)	129 (5.08)	127 (5.00)
40*	1½"	156 (6.14)	102 (4.00)	98 (3.86)	79 (3.11)	229 (9.02)	49 (1.93)	164 (6.46)	192 (7.56)	158 (6.22)	22 (0.87)	161 (6.34)	159 (6.26)
50	2"	156 (6.14)	156 (6.14)	121 (4.76)	98 (3.86)	238 (9.37)	49 (1.93)	236 (9.29)	235 (9.25)	199 (7.83)	22 (0.87)	192 (7.56)	191 (7.52)
65	2½"	222 (8.74)	156 (6.14)	138 (5.43)	121 (4.76)	359 (14.13)	68 (2.68)	244 (9.61)	266 (10.47)	241 (9.49)	22 (0.87)	218 (8.58)	216 (8.50)
80	3"	222 (8.74)	222 (8.74)	158 (6.24)	138 (5.43)	373 (14.69)	74 (2.90)	363 (14.29)	306 (12.05)	270 (10.63)	22 (0.87)	256 (10.08)	254 (10.00)
100	4"	222 (8.74)	222 (8.74)	158 (6.24)	158 (6.24)	381 (15.00)	74 (2.90)	381 (15.00)	314 (12.36)	314 (12.36)	22 (0.87)	218 (8.58)	305 (11.96)

\* DN32 DIN uses DN25. DN32 ISO 1127 uses DN40.

ASME BPE clamp short length dimension – see page 11.

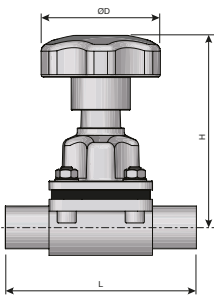

Forged

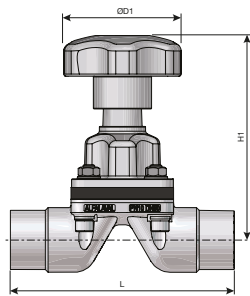

Cast

Size	ØD	ØD1	H	H1	L (weld ends)	L (clamp)	
DN	Inch	mm (in)	mm (in)	mm (in)	mm (in)	mm (in)	
8-10	¼"-¾"	40 (1.57)	40 (1.57)	72 (2.83)	73 (2.87)	89 (3.50)	89 (3.50)
15	½"	62 (2.44)	40 (1.57)	101 (3.98)	73 (2.87)	110 (4.33)	108 (4.25)
20	¾"	62 (2.44)	62 (2.44)	113 (4.45)	104 (4.09)	119 (4.68)	118 (4.65)
25*	1"	87 (3.42)	62 (2.44)	129 (5.08)	115 (4.53)	129 (5.08)	127 (5.00)
40*	1½"	108 (4.25)	87 (3.42)	149 (5.87)	132 (5.20)	161 (6.34)	159 (6.26)
50	2"	108 (4.25)	108 (4.25)	197 (7.76)	156 (6.14)	192 (7.56)	191 (7.52)
65	2½"	172 (6.78)	108 (4.25)	227 (8.94)	203 (7.99)	218 (8.58)	216 (8.50)
80	3"	220 (8.66)	172 (6.78)	260 (10.24)	231 (9.09)	256 (10.08)	254 (10.00)
100	4"	220 (8.66)	220 (8.66)	268 (10.55)	268 (10.55)	218 (8.58)	305 (11.96)

\* DN32 DIN uses DN25. DN32 ISO 1127 uses DN40.

ASME BPE clamp short length dimension – see page 11.

H measurement when handle is fully open.

# Two-way valve drainability

Drainability is critical in the pharmaceutical and biotech industries. Alfa Laval Unique DV-ST UltraPure two-way diaphragm valves offer full drainability, when the valve is mounted at the correct angle. The table below shows the angles necessary for full drainability.

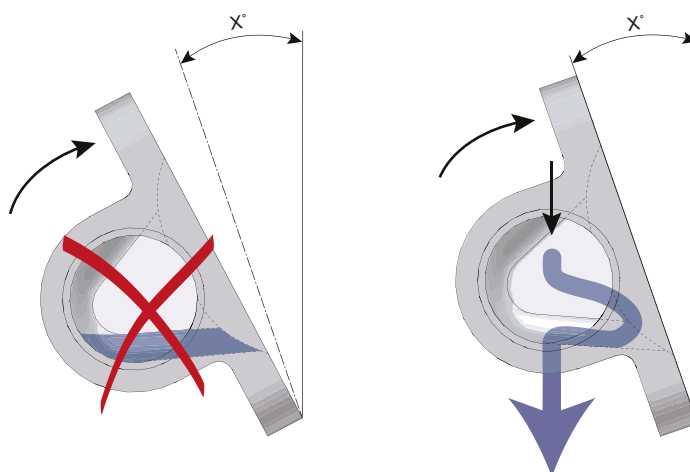

## Drain angles, forged and block valve bodies

Port size		ASME BPE	ISO 2037	DIN11850 (Series A)	ISO 1127 (Series B)	ASME BPE
DN	Inch					
8	¼"	42°	27°	32°	26°	38°
10	⅜"	33°	25°	35°	28°	30°
15	½"	35°	26°	24°	20°	26
20	¾"	34°	30°	28°	23°	–
25	1"	29°	29°	25°	21°	–
32	1 ¼"	–	–	18°	26°	–
40	1 ½"	30°	29°	27°	22°	–
50	2"	25°	24°	24°	20°	–
65	2 ½"	23°	23°	20°	16°	–
80	3"	26°	27°	23°	22°	–
100	4"	14°	14°	13°	8°	–

## Drain angles, cast valve body

Port size		ASME BPE	ISO 2037
DN	Inch		
15	½"	26.5°	7°
20	¾"	20°	14°
25	1"	22.7°	22°
40	1 ½"	13.8°	13°
50	2"	16.1°	15°
65	2 ½"	14.7°	15°
80	3"	14.9°	15°



# Kv value

To ensure that valves of the correct size are installed in a system, it is necessary to know the rate at which the fluid flows through the valves under specific conditions. Using metric measurements, this is calculated using the Kv value, which is also known as the flow factor or flow coefficient.

The Kv value is defined as the flow in cubic metres per hour of water, at a pressure drop (differential pressure) across the valve of 1 bar, when fully open, at a temperature between 5°C and 30°C.

In countries that use imperial measurements, the Cv value is often used. The Cv value is defined as the flow in US gallons per minute, at a pressure drop (differential pressure) across the valve of 1 psi, when fully open, at a temperature of 60°F. The Cv value can be calculated from the Kv value using the formula:  **$Cv = 1.156 \times Kv$**

The tables below specify the Kv values for Alfa Laval Unique DV-ST UltraPure two-way valves of different types and sizes.

$$Kv = Q / \sqrt{\Delta P}$$

Q = the flow rate (expressed in cubic metres per hour),  
 $\Delta P$  = the differential pressure across the device (expressed in bars).

## Kv value or flow coefficient

Kv value (pipe standard ISO 1127 / DIN/A), forged and block

Kv in m <sup>3</sup> /h $\Delta p = 1$ bar or 14.5 psi								
DN 8–10 (¼"–3.8")	DN 15 (½")	DN 20 (¾")	DN 25 (1")	DN 40 (1½")	DN 50 (2")	DN 65 (2½")	DN 80 (3")	DN 100 (4")
1.6	4.2	8.8	13.1	41.0	69.4	94.3	152.0	204.9

Kv value (pipe standard ASME BPE), forged and block

Kv in m <sup>3</sup> /h $\Delta p = 1$ bar or 14.5 psi								
DN 8–10 (¼"–3.8")	DN 15 (½")	DN 20 (¾")	DN 25 (1")	DN 40 (1½")	DN 50 (2")	DN 65 (2½")	DN 80 (3")	DN 100 (4")
0.2	2.2	4.8	9.5	23.9	46.5	69.7	111.7	200.0

Kv value (pipe standard ASME BPE and ISO 2037), cast

Kv in m <sup>3</sup> /h $\Delta p = 1$ bar or 14.5 psi								
DN 8–10 (¼"–3.8")	DN 15 (½")	DN 20 (¾")	DN 25 (1")	DN 40 (1½")	DN 50 (2")	DN 65 (2½")	DN 80 (3")	DN 100 (4")
0.2	2.2	5.1	10.8	25.3	53.4	79.7	128.6	200.0

$$Cv = 1.156 \times Kv$$

Note for the diagrams the following applies:

Medium: Water (20°C/68°F).

Measurement: In accordance with VDI2173.

# T-valves

Alfa Laval Unique DV-ST UltraPure T-valves are machined from a single block in either 1.4435/316L or in an optional high-performance material, thereby avoiding weld seams. Often used in water distribution systems, they offer minimal deadleg, low weight, and compact size.

Alfa Laval can customize T-valves according to your exact needs and specifications, and they can be made to suit almost any configuration and application. Below are some examples of the most common T-valve designs in the Alfa Laval Unique DV-ST UltraPure range. Other designs are available upon request.

## Zero deadleg T-valve

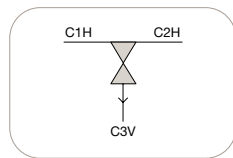

Key
C = Connection
V = Vertical
H = Horizontal
W = Weir

Sampling and steam access points can also be incorporated into the design of your T-valve.

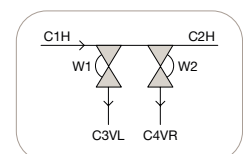
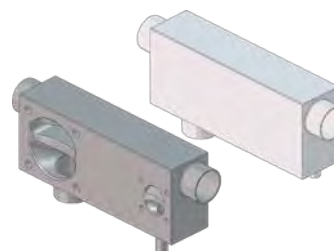
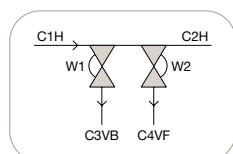
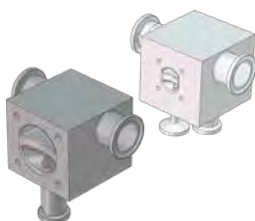
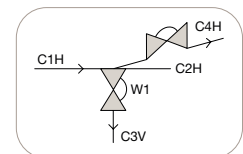
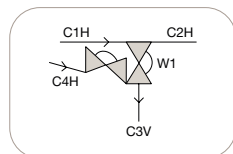

Other designs available upon request.

# Tank outlet valves

Alfa Laval Unique DV-ST UltraPure tank outlet valves are machined from a single block in either 1.4435/316L or in an optional high-performance material. This makes them ideal for mixing tanks with a limited sump area, since the design minimizes mixing dead zones.

Get customized tank outlet valves according to your exact specifications and in accordance with their intended application. Below are some of the most common tank outlet valve designs in the Alfa Laval Unique DV-ST UltraPure range. Other designs are available upon request.

## Block tank outlet valve

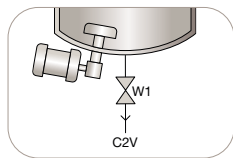

Key
C = Connection
V = Vertical
H = Horizontal
W = Weir

Sampling and steam access points can also be incorporated into the design of your tank outlet valve as part of our standard multiport tank valve range.

## Tank outlet valve with access point before weir, on left or right (suitable for sampling)

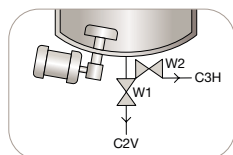
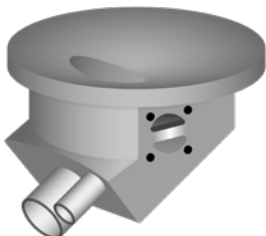

## Tank outlet valve with access point after weir, on left or right (suitable for steam purging)

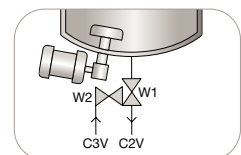
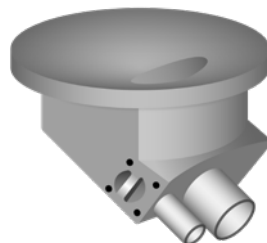

Other designs available upon request.

# Tandem valves

Tandem valves can help simplify pipework by replacing conventional valve and fitting combinations. Compact Alfa Laval tandem valves incorporate minimal deadleg and full drainability design.

Alfa Laval Unique DV-ST UltraPure tandem valves are available either as integral access valves (IAV) or as standard welded tandem valves. Our IAV block valves are available in a wide range of configurations and can be designed to fit your specific requirements. Our standard tandem valves are available either as forged or cast.

## Standard tandem valve combinations

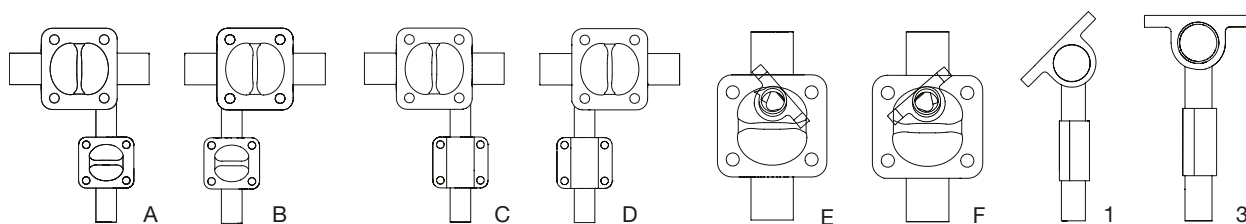

## DV-ST integral access valve (IAV)

For demanding duties where a deadleg-free system is required, Alfa Laval offers a tandem block valve solution. The compact, weld-free design ensures full drainability and zero deadleg.

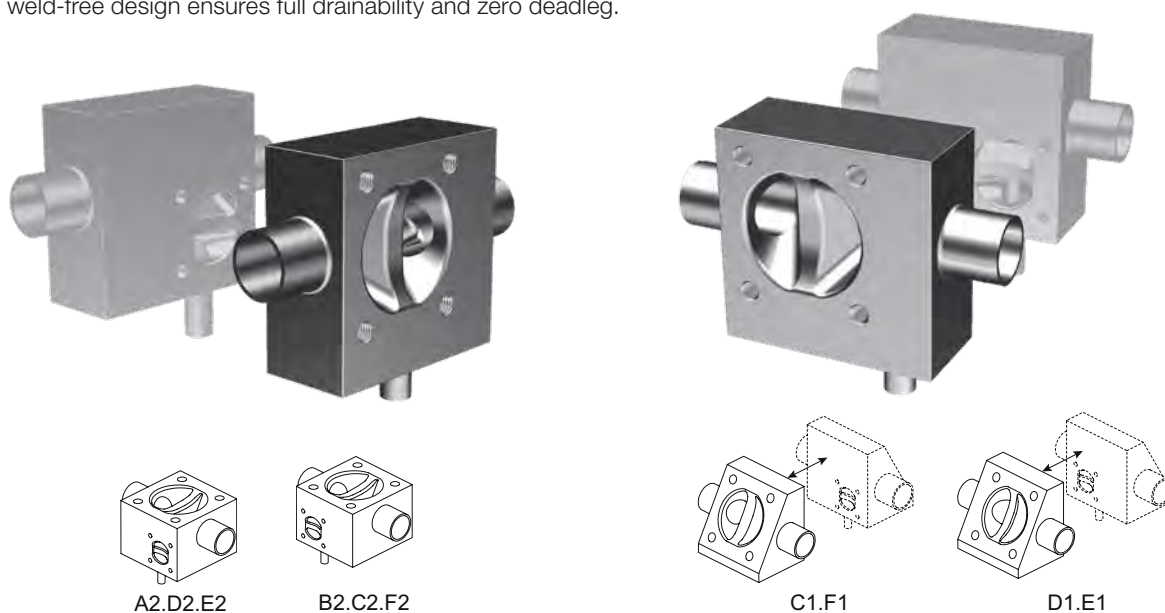

# Multiport diaphragm valves

The ultimate in process design, Alfa Laval Unique DV-ST UltraPure multiport diaphragm valves combine multiple functions in a single valve body. This saves time and space, while minimizing deadleg, maximizing drainability, and improving system performance. These customized solutions are suitable for both simple and complex processes; they also provide a more reliable and efficient alternative to valve clusters.

Our multiport valves are customized to suit the most demanding pharmaceutical and biotech applications. Machined from a solid block, they are available in 316L or 1.4435 stainless steel, as well as high-alloy options like AL-6XN, Hastelloy C22, and Duplex for highly corrosive and aggressive applications.

Optimize the design of multiport valves to your specific application and processes. Alfa Laval achieves stand-out product design by combining state-of-the-art machining techniques with an experienced design team, and most importantly, through communication with our customers.

## Benefits

- Reduced product holdup, maximizing yield
- Reduced deadleg
- Optimized drainability
- Fewer welds
- Compact design
- Easy validation and conformance to international standards
- Reduced complex pipework
- Safe distribution of product

## Typical applications

- Product distribution
- Sampling
- Mixing
- Bypass drain
- System sterilization
- Point of use
- Double block-and-bleed (DBB) solutions

## Examples of possible multiports configurations

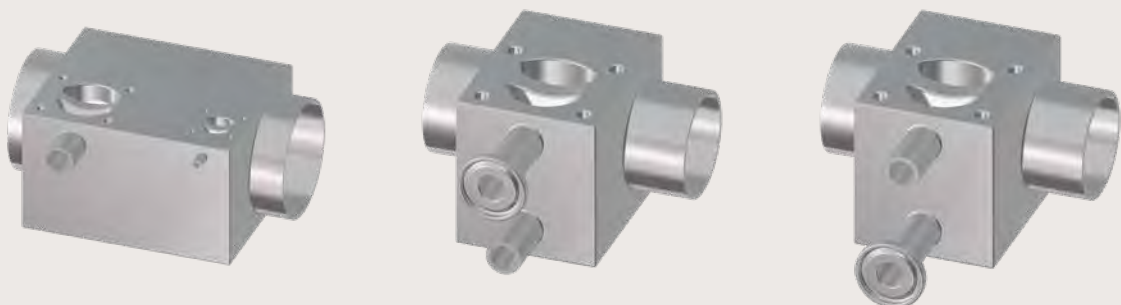

## Chromatography multiport designs

Alfa Laval can create multiport diaphragm valves for almost any application. These examples are particularly suited for chromatography applications.

### Key

C = Connection

V = Vertical

H = Horizontal

W = Weir

**Chromatography without bypass: This four-seat valve block links any port alternatively to two adjacent ports (distribution/collection in vertical or horizontal position)**

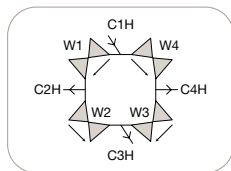
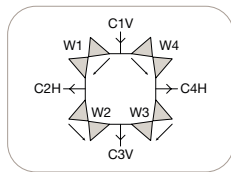

**Chromatography with bypass: This five-seat valve block links ports to two adjacent ports, (distribution/collection in vertical or horizontal installation)**

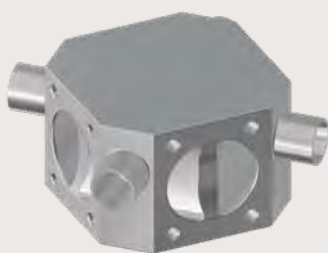
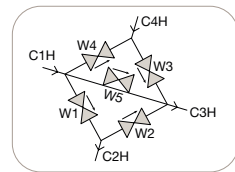

## Multiport valves

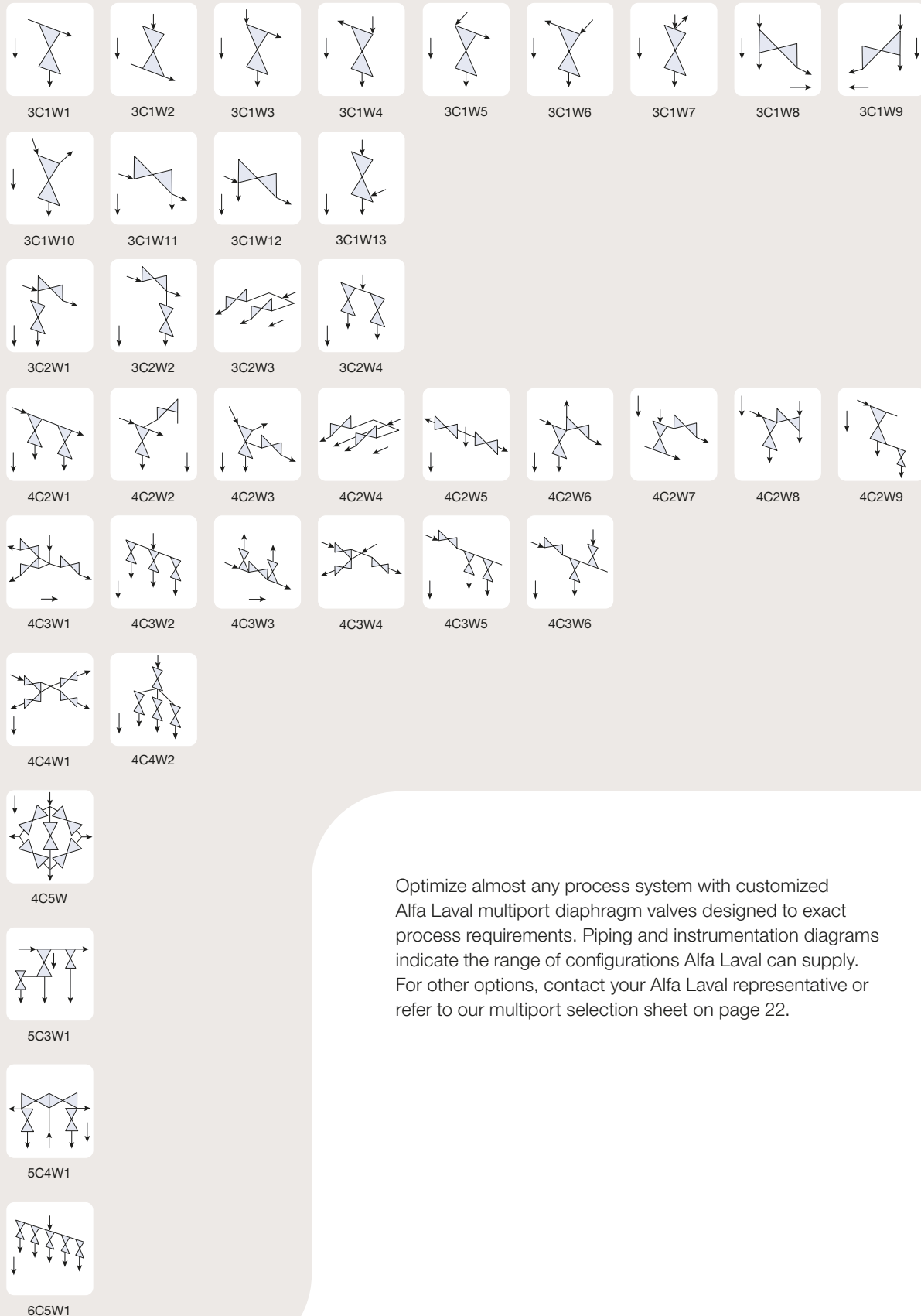

Optimize almost any process system with customized Alfa Laval multiport diaphragm valves designed to exact process requirements. Piping and instrumentation diagrams indicate the range of configurations Alfa Laval can supply. For other options, contact your Alfa Laval representative or refer to our multiport selection sheet on page 22.

# How to specify and order a multiport diaphragm valve

Getting the right multiport valve design is crucial for maximizing system performance and flexibility. On the next page, you'll find a specification sheet to record the necessary information for each multiport valve.

## The key information required to design your multiport valve includes:

- Details of operating conditions
- Functions you wish the valve to perform
- Flow diagram of the system
- Connection type, size, standard, etc., for every connection
- Valve position, i.e., vertical or horizontal
- Drain direction
- Surface finish
- Diaphragm type
- Whether intended for pneumatic or manual operation
- Any other relevant details

Get the right multiport valve design



# Multiblock configuration quotation form

## Multiblock configuration – Quotation form



Commercial data		Contact data	
Project/reference no.		Company name	
Quantity		Department	
Single request		Contact	
Serial request		Phone	
Other information		E-mail	

Technical data	
Media	
Pressure	
Temperature (media)	
Viscosity	
Kv value (flow)	

Mark, X or describe other option desired:

Block material	1.4404 (316L)	1.4435	1.4435 BN2	Other
Diaphragm material	EPDM	PTFE/EPDM	TFM/EPDM	Other
Surface finish internal	0.5 µm (SF1)	0.4 µm EP (SF4)	Other in µm	
Surface finish external	3.2 µm	Other in µm		

Please draw flow diagram

Example

Diaphragm valve	
Area with min. volume	-----
Drainability	
Flow of medium	
C1, C2 .... connections	C1...CN
Orientation of connections	V (vertical) or H (horizontal)

Key	
C	Connection
V	Vertical
H	Horizontal
W	Weir

page 2/2



C Number	DN (inch)	Connection standard				Connection type		Operation		Other Actuator type/ automation
		DIN/A	ISO B	ISO 2037	ASME	Clamp	Weld ends	Manual	Pneumatic (NC, NO, A/A)	
C1										
C2										
C3										
C4										
C5										
C6										
C7										
C8										
C9										
C10										

# Diaphragms

In pharmaceutical, biotech and other industries that demand ultra-hygienic conditions, the large number of variables can make it difficult to find the correct diaphragm. Depending on the application, diaphragm materials may require compatibility with high temperatures, steam, aggressive chemicals and even living organisms. They must also conform to applicable regulations to allow the system to be validated.

To meet these demands, the Alfa Laval Unique DV-ST UltraPure valves include a range of diaphragms suitable for countless applications and environments. They are designed to maximize uptime and minimize the risk of product contamination, regardless of the industry in which they are used. For easy maintenance, we provide compound tracking on all diaphragms, to ensure the use of like-for-like spare parts and to make revalidation easier.

The diaphragms are available as soft elastomer (EPDM) as well as hard elastomers (PTFE/EPDM and TFM/EPDM). The hard elastomers are supported by a soft elastomer (EPDM). The two-piece design allows the two elastomers to work independently of each other, thereby reducing tension caused by different thermal properties.

Stand-out features include bayonet connections to prolong diaphragm life, compatibility with steam of temperatures up to 150°C (continuous temperature for EPDM; 40 minutes for PTFE/EPDM and TFM/EPDM), and the option of a single-layer for faster leak detection.

All diaphragms are in compliance with the ASME BPE Standard and hold Certificates of Compliance according to ASME BPE table PM-2.2.1-1.



EPDM Screw connection



EPDM Plug connection



PTFE/EPDM Bayonet connection

## Alfa Laval Unique DV-ST UltraPure diaphragms

Description	Temperature recommendations			Documentation			Available sizes	Diaphragm connection type		
	Min	Max liquid	Max steam	FDA	USP Class VI	TSE/ADI		Button	Thread	Bayonet
EPDM	-40°C (-40°F)	150°C (302°F)	150°C*** (302°F)	Yes	Yes	Yes	DN 8-100	DN 8-20*	DN 25-100	
PTFE/EPDM	-5°C (23°F)	175°C (347°F)	150°C**** (302°F)	Yes	Yes	Yes	DN 15-100			DN 15-100
TFM/EPDM	-5°C (23°F)	175°C (347°F)	150°C**** (302°F)	Yes	Yes	Yes	DN 8-100	DN 8-10	**	DN 15-100

\* DN 15 & 20 Optional thread available    \*\* Optional thread available    \*\*\* Continuous temperature    \*\*\*\* 40 minute steam sterilization

FDA: Declaration of Conformity to FDA (21:177.2600 or 177.1550).

USP: Certificate of conformity, Biocompatibility complying to:

- USP directive <87>, Biological Reactivity Test in-vitro.

- USP Class VI <88>, Biological Reactivity Test in-vivo.

TSE/ADI Declaration: declared free from Transmissible Spongiform Encephalopathy and Animal-Derived Ingredients.

## Diaphragm coding

Alfa Laval Unique DV-ST UltraPure diaphragms are clearly coded to ensure easy verification of replacement diaphragms or other parts such as actuators. Key information such as size, material grade, cure date and supplier code are moulded into every diaphragm to help you select the correct parts for your valve.

### EPDM diaphragm

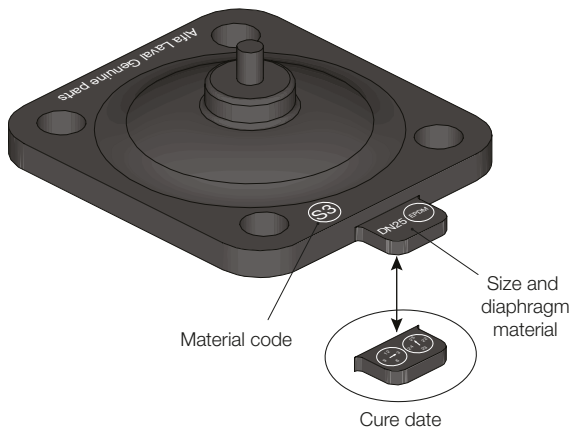

### PTFE/EPDM diaphragm

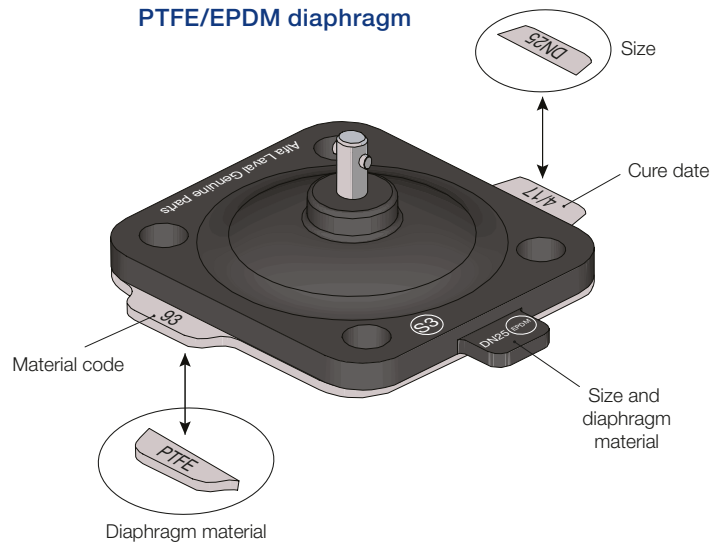

Clearly coded  
for easy verification  
and replacement.



# Sealing systems

The Alfa Laval Unique DV-ST UltraPure diaphragm valve sealing system is designed to have a flat surface between the body, diaphragm and bonnet. This ensures that the diaphragm is not pinched in a critical high stress area, which helps extend diaphragm lifetime. It also reduces the risk of diaphragm stress fractures, which can create undetectable, non-cleanable crevices that cause contamination.

The Alfa Laval sealing system has a pressure rating of 10 bar (145 psi). Holding pressure varies depending on diaphragm type, actuator type and valve size. See pages on actuators.

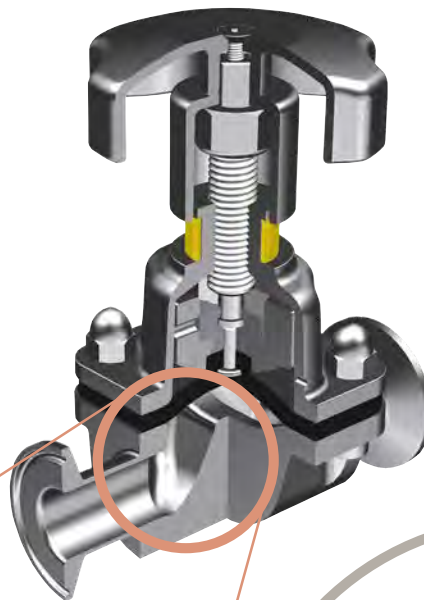

High-stress pinching of the diaphragm can cause cracking and the potential for bacterial growth. The round sealing bead on the body flange in this example can also cause encapsulation media behind the sealing ridge, further risking bacterial growth and resisting cleaning.

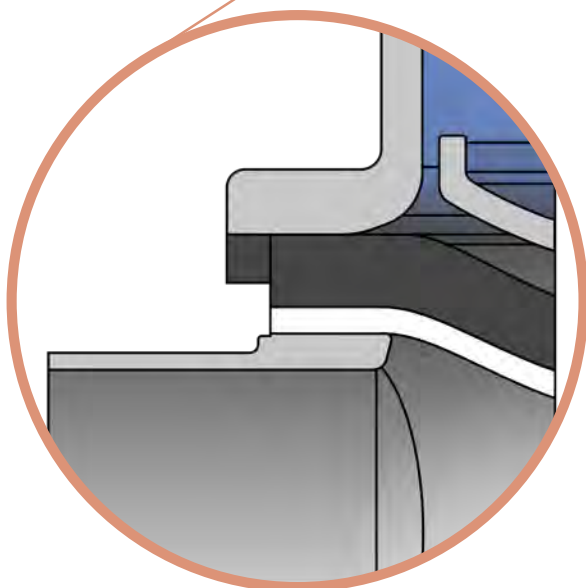

**Alfa Laval sealing system**

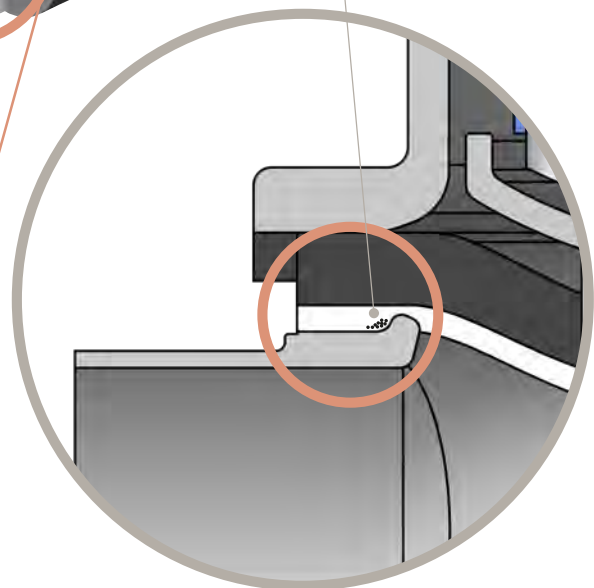

**Competitors' sealing system**

# Alfa Laval Q-doc

Alfa Laval Q-doc is a comprehensive documentation package that ensures safe and easy commissioning, validation and maintenance of Alfa Laval products, including Unique DV-ST UltraPure diaphragm valves. The Q-doc package includes the required certificates and declarations related to traceability of materials, surface finish and performance.

Compound tracking of the diaphragm also ensures that the correct diaphragm material is always used during maintenance. Alfa Laval Q-doc is supplied with every diaphragm valve and spare part upon delivery and can also be downloaded from our website, <https://findmycert.alfalaval.com/>

## The Q-doc package includes:

- 3.1/ MTR traceability certificate corresponding to EN 10204
- Compound ID (for non-metallic materials)
- Cure date (for diaphragm)
- FDA – Declaration of conformity to FDA (CFR 21: 177. 2600 or 177.1550)
- USP – Certificate of conformity to USP Class VI (chapter 87 and 88)
- TSE/ADI – Declaration (Transmissible Spongiform Encephalopathy / Animal-Derived Ingredients)
- Surface finish conformity declaration
- Easy identification of service kit needed for servicing valve

## The following documentation is available upon request:

- Surface finish certificate (Ra test results)
- ATEX certificate
- Passivation certificate
- Electropolishing certificate

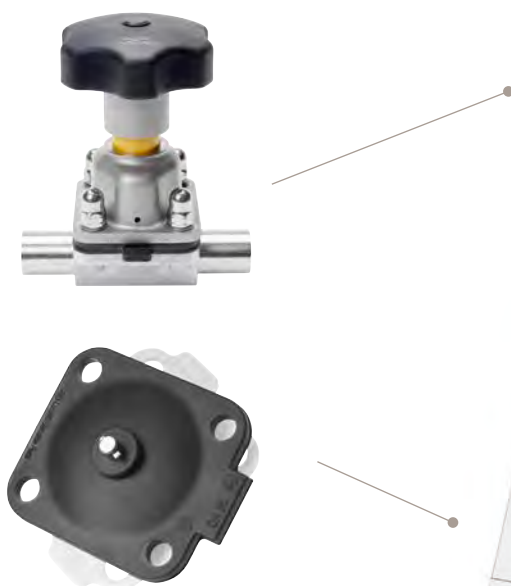

# An example of Alfa Laval Unique DV-ST UltraPure Q-Doc documentation



**Alfa Laval Unique DV-ST UltraPure**

---

**Equipment documentation**  
Doc. ID no.: 9614076502 Alfa Laval Q-doc Unique DV-ST UltraPure - Revision 3.0

**Order information**

<b>Serial No :</b> E227258-01	P&ID reference:
<b>Item No :</b> 9615385408	Item Description: DV-ST UP FGD 2-W DN15 ASME BPE W 0.4EP SF4 PTFE/EPDM MAN SS/SS QDOC
<b>Order No :</b> 535615	



Page 2 of 3

**Equipment Documentation**  
**Alfa Laval Unique DV-ST UltraPure**

**Serial No: E227258-01**

**Declaration of Compliance**

**Supplier**  
Alfa Laval Eastbourne Ltd  
Birch Road, Eastbourne, BN23 6PQ, UK  
Phone: +44 (0) 1323 412555  
E-mail: info@alfalaval.com

**Compliance with Regulation (EC) No: 1935/2004**  
We declare that the above mentioned equipment complies with the Regulation (EC) No. 1935/2004 regarding "Materials and articles intended to come into contact with food".

**Compliance to the EC regulation for GMP**  
We as a supplier hereby guarantee and certify that the product is manufactured in accordance with the requirements of Commission Regulation (EC) no. 2023/2006 on Good Manufacturing Practice (GMP) for materials and articles intended for contact with food.

**Compliance to EN 10204 type 3.1 (MTR)**  
We declare that the product wetted steel parts listed in table on page 3 of this document comply with the European Standard EN 10204: 2004 Inspection certificate type 3.1.  
3.1 certificates (MTR's) are attached to this document

**Compliance to the U.S. Food & Drug Administration CFR 21 (non-metallic parts)**  
We declare that the product contact non-metallic parts, elastomers and polymers, listed in table on page 3 of this document are compliant with the U.S. Code of Federal Regulations (CFR) section 21 Food and Drug Administration (FDA). Polymers are in accordance to CFR 21, part 177 (Indirect Food Additives: Polymers), Section 2600 (Rubber Articles Intended for Repeated Use) and Section 1550 (Perfluorocarbon resins). FDA declarations from our suppliers can be forwarded upon request.

**Compliance to the U.S. Pharmacopoeia (USP) (Elastomers and polymers)**  
We declare that the non-metallic parts listed in table on page 3 of this document have been tested and certified by an independent laboratory to be compliant with the criteria of the U.S. Pharmacopoeia Chapter 88 Class VI (Biological reactivity test), In Vivo and Chapter 87 (cytotoxicity of the sample in vitro). USP declarations from our suppliers can be forwarded upon request.

**TSE (Transmissible Spongiform Encephalopathy) / ADI (Animal Derivative Ingredient) Declaration**  
We declare that the product contact parts listed in the tables on page 3 of this document are ADI free. Consequently, these parts do not contain Specific Risk Materials (SRM's) associated with risk of TSE/ADI. TSE/ADI declarations from our suppliers can be forwarded upon request.

**Surface finish compliance declaration**  
In accordance with Alfa Laval quality procedures we declare that the surface finish of the product contact metallic parts listed in the table on page 3 of this document have a surface finish characteristic in accordance with the specification of the equipment. Surface finish is inspected in accordance with the criteria listed in ASME BPE tables SF-2.2-1 and SF-2.2.2 (Electro polished).

  
 Lars Kruse Andersen  
 Global Product Quality Manager, Alfa Laval

Page 3 of 3

**Equipment Documentation**  
**Alfa Laval Unique DV-ST UltraPure**

**Serial No. : E227258-01**

**Product wetted metallic parts, 3.1 according to EN 10204 (MTR) traceability**

Item no.	Item description	Qty	Material	Lot no.	Heat no.
9614109905	BODY DV FGD DN15 ASME W 0.4EP	1	1.4435/316L	225318	426465

**Product wetted non metallic parts**

Item no.	Item description	Qty	Material	Lot no. Cure date	Batch no. Compound ID
9614119201	DIAPHRAGM PTFE FACING DN15-1/2	1	PTFE	191216037 01 Nov 2019	305222 4562 '93'
9614119301	BACKING EPDM DN15-1/2in	1	EPDM	216858 01 Jun 2019	116265 AA7LTZ 'S4'

**Service kit**

Item no.	Item description
9615000154	DIAPHRAGM PTFE/EPDM DN15-1/2"

**This Q Doc contains the following**

Supplier Heat Certificates	Yes
Surface Finish Certificate	No

**Responsibilities (for internal use only)**  
The responsible person from each department who have performed test or entered data to this document must approve and sign. By signing this document the responsible person hereby declares that the instructions are followed and the requirements met in the appropriate procedures or Technical Specification of this document.

**QC Inspector - Robin Mills**      19 May 2020 

VAT Registered No: GB 102 5620 64  
Registered in England No: 7427524  
Registered Office: Birch Road Eastbourne BN23 6PQ

Page 1

**FEAT GROUP S.p.A.**  
FEAT INDUSTRIALE DIVISION

**Cert N. 2018/3002274**      Date 16/05/2018      Page 1

**ALFA LAVAL KOLDING A/S**  
ALBUEN, 31 - P.O. BOX 802  
6000 KOLDING

**Customer orders**      **Delivery Note**      **Invoice**      **Delivered Qty**  
P 838277      2018/000/0030723      O 0030757      1.004,00

**Feat Code**      **Description**      **Customer Code**  
668002163001      RAW BODY DN15 1/2"      9614119301

**Customer Drawing**      **Rev**  
96141611

**Material & Specification**  
1.4435/F316L5      DIN EN 10222-5, ASTM A182/ASME BPE-2009 Last Ed  
(BASEL NORM EN2)

**Heat Number**      **Steel Mill**      **Trade Mark**      **Forging Code**  
426465      ACCIAIERIE VALBRUNA S.P.A.      P      IL



**Chemical Analysis**

Item	Si	C	Co	Cr	Cu	Mn	N	Ni	P	S	Se	Ti
Min				17,000		2,000		12,500		0,010		
Max	7,700	0,030	0,200	18,000	0,500	2,000	3,000	0,100	14,000	0,040	0,015	0,750

**Mechanical Properties / Heat Treatment**

Laboratory Order	N	Description	UNI	Min	Max	Value	UNI	Value
668-IL	[01]	Re 1% T +20C	[N/m2]	235.000		285.000	[PSI]	40745.000
668-IL	[01]	Re 0,2% T +20C	[N/m2]	200.000		261.000	[PSI]	37845.000
668-IL	[01]	Re T +20C	[N/m2]	320.000	670.000	374.000	[PSI]	83230.000
668-IL	[01]	Re T Iso-20C +20C	[N]	30.000		52.000		
668-IL	[01]	Re T Iso-20C +20C	[N]	35.000		48.000		
668-IL	[01]	Re T +20C	[N]	56.000		82.000		
668-IL	[01]	Re T +20C	[J]	60.000		144.000		
668-IL	[02]	[J]		60.000		122.000		
668-IL	[03]	[J]		60.000		128.000		
668-IL	[01]	Average RW	[N]	1050.000	200.000	149.000		
668-IL	[01]	Inclusion annealing	[Degree C]	1050.000	1070.000	OK		
668-IL	[01]	Holding Time	[hour/25mm]	1.000		OK		
668-IL	[01]	Rescue Cooling	[Degree C]	24.000	40.000	OK		

**Remarks**  
3.1 CERTIFICATE ACCORDING TO EN 10204 LAST EDITION  
Attached: -Steel Mill Certificate

**Filed in:**       **Labouratory Manager:** 

# Actuators

Maintenance-free Alfa Laval actuators are ATEX-compliant and meet the rigorous aseptic demands of the pharmaceutical industry. The standard energy-efficient stainless steel slim actuator (SS/SL) is fully welded and handles a wide range of pressures; the stainless steel high-pressure actuator (SS/HP) is optimized for special applications at higher operating pressures.



Model	SS/SL	SS/HP
Sizes		DN 8–100 (¼"–4")
Housing		Stainless steel
Intermediate part		Stainless steel
Compressor, steam		Stainless steel
Full vacuum		Yes
Leakage detection		Yes
Autoclavable <sup>1</sup>		Yes
Max. air temperature		80°C
Max. air pressure <sup>2</sup>		7 bar (102 psi)
ATEX		Yes II 2G Ex h IIB T4 Gb (–10°C/14°F ≤ t <sub>amb</sub> ≤ 80°C/176°F) II 3D Ex h IIIB T (100°C/212°F) Dc (–10°C/14°F ≤ t <sub>amb</sub> ≤ 80°C/176°F)
Stroke limiter	Yes	No
Max working pressure	ΔP 100% <sup>3</sup>	ΔP 0% <sup>3</sup>
Sizes	¼"–1½" EPDM 10 bar (145 psi) PTFE/EPDM 6 bar (87 psi) TFM/EPDM 6 bar (87 psi)	¼"–4" EPDM 10 bar (145 psi) PTFE/EPDM 10 bar (145 psi) TFM/EPDM 6 bar (87 psi)
	2"–4" EPDM 8 bar (116 psi) PTFE/EPDM 5 bar (72.5 psi) TFM/EPDM 5 bar (72.5 psi)	

<sup>1</sup> 121°C (250°F) for maximum 60 minutes.  
<sup>2</sup> Minimum air pressure see instruction manual.  
<sup>3</sup> See image below for ΔP 100% and ΔP 0%.

## Maximum working pressure

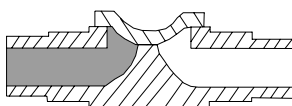

**100% pressure drop (Δp).** When pressure is only on one side of the diaphragm and the outlet is open to atmospheric pressure, less force is required to close the valve.

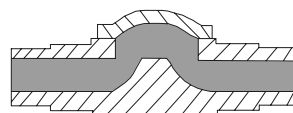

**0% pressure drop (Δp).** When pressure is exerted on both sides of the diaphragm, more force is required to close the valve.

## Product pressure versus control pressure SS/SL actuator

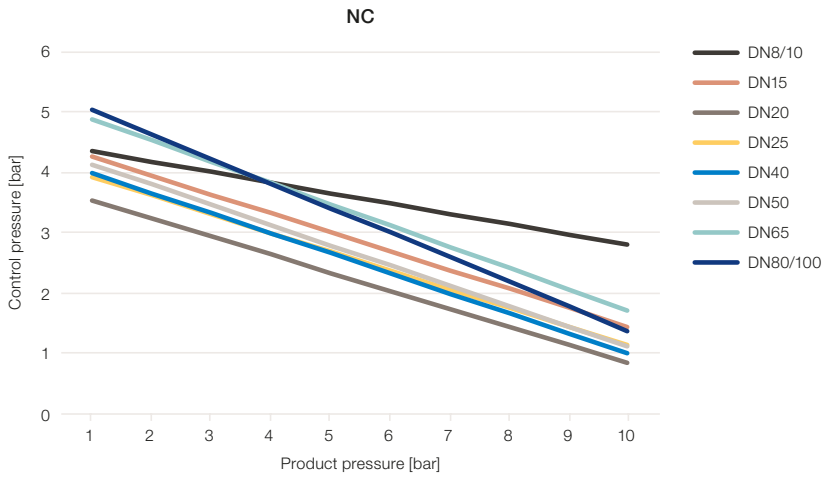

### Description

The diagrams state the required control pressure on the actuator at a given product pressure in the system.

### NC (Normally Closed)

Control pressure is used for opening the valve. Here the required control pressure is reduced when the product pressure is increased. When the air supply is interrupted, the actuator will close the valve.

### NO (Normally Open)

Control pressure is used for closing the valve. Here the required control pressure is increased when the product pressure is increased. When the air supply is interrupted, the actuator will open the valve.

### A/A (Air/Air)

Control pressure is used for both opening and closing of the valve. Here the required control pressure is increased when the product pressure is increased. When the air supply is interrupted, the valve will open at positive product pressure and close at negative product pressure

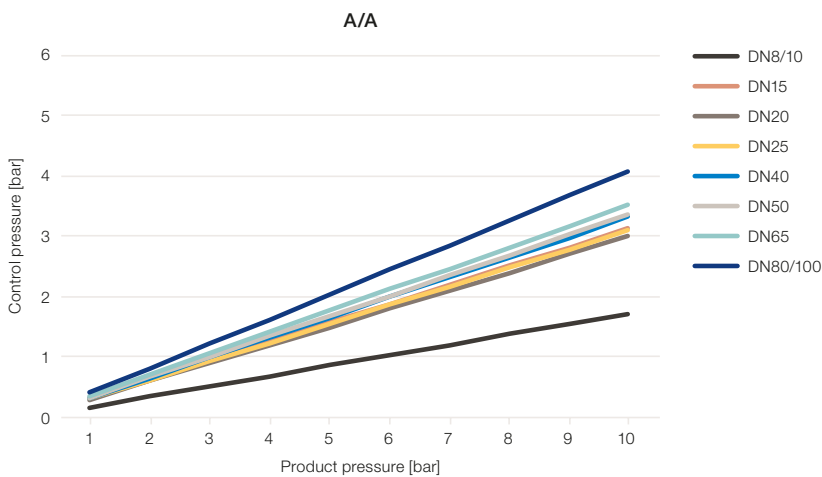
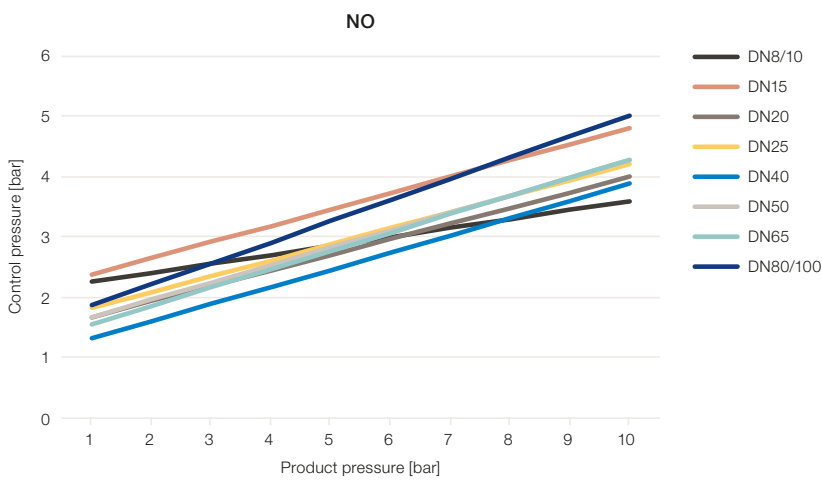

## Product pressure versus control pressure SS/HP actuator

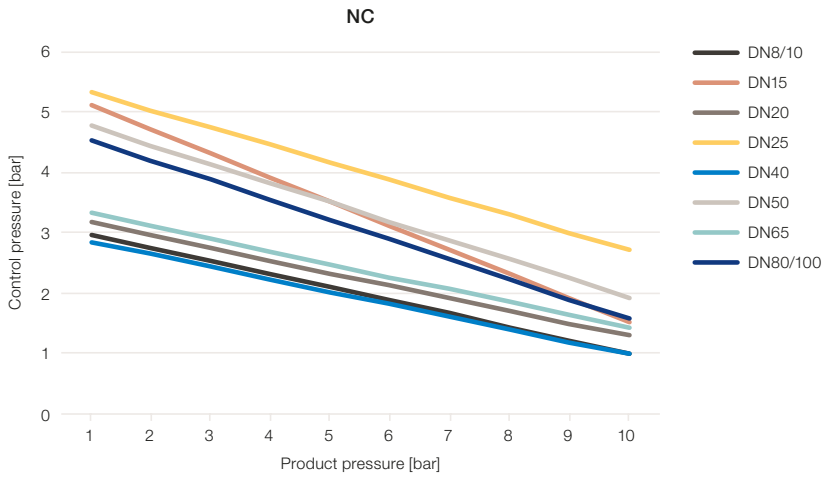

### Description

The diagrams state the required control pressure on the actuator at a given product pressure in the system.

### NC (Normally Closed)

Control pressure is used for opening the valve. Here the required control pressure is reduced when the product pressure is increased. When the air supply is interrupted, the actuator will close the valve.

### NO (Normally Open)

Control pressure is used for closing the valve. Here the required control pressure is increased when the product pressure is increased. When the air supply is interrupted, the actuator will open the valve.

### A/A (Air/Air)

Control pressure is used for both opening and closing of the valve. Here the required control pressure is increased when the product pressure is increased. When the air supply is interrupted, the valve will open at positive product pressure and close at negative product pressure

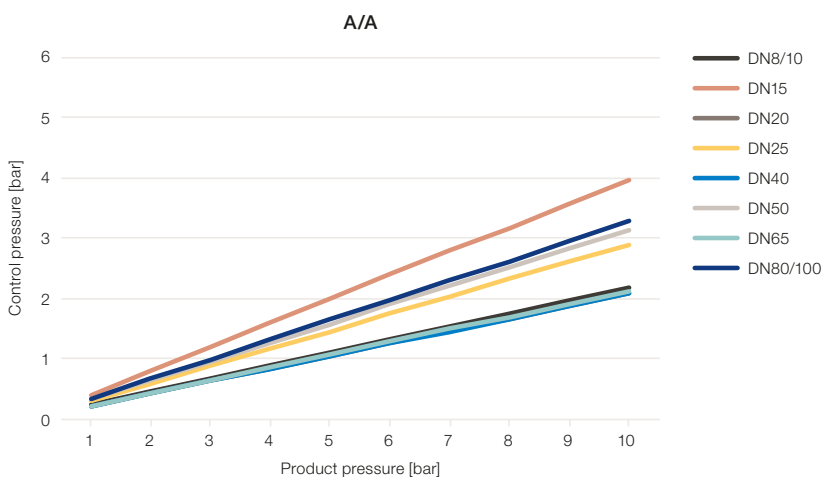
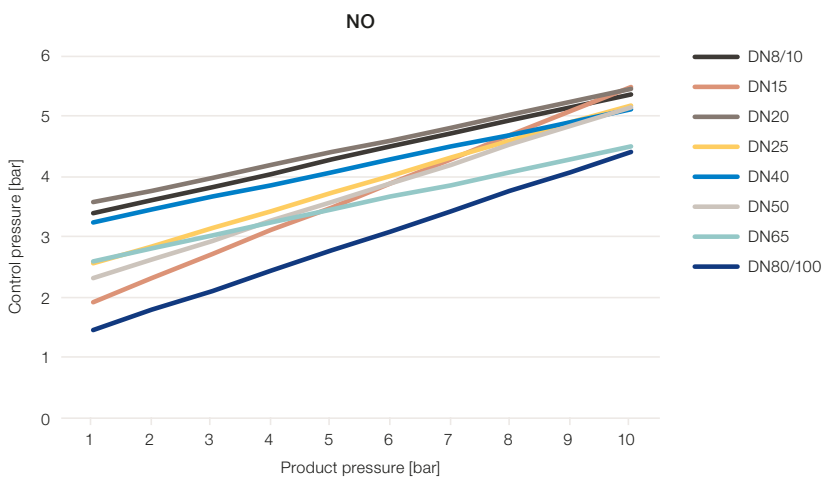

# Sensing and control

Alfa Laval Unique DV-ST UltraPure diaphragm valves can be fitted with a full range of accurate valve automation solutions to meet your exact process requirements.

Options include control units that suit AS-Interface, IO-Link and digital operating platforms. The range can suit the most basic information about valve position to more sophisticated options including control top units with solenoids or 4–20 mA positioners.

Quick and easy to install, the Alfa Laval control top range has been developed over many years based on vast experience from the pharmaceutical, biotech and other industries where precise valve control is a must.



## Automation for DV-ST UltraPure diaphragm valve



Sensing and control	Valve position feedback	Valve actuator size	Solenoid valve	Optical indication	Interface	Protection class	Electrical connection	Air connection	ATEX
Indication sensor	Open	8-100	No	LED	Digital	IP65	M8 plug	None	No
IndiTop	Open/closed	15-100	No	LED	Digital	IP66/IP67	Cable/M12 plug	None	No
ThinkTop D30	Open/closed	8-50	Yes	LED 360	Digital	IP66/IP67	Cable	6 mm (¼")	No
ThinkTop Basic	Open/closed	15-100	Yes/No	LED	Digital/AS-I	IP66/IP67	Cable/M12 plug	6 mm (¼")	Option
ThinkTop V50	Open/closed	15-100	Yes/No	LED 360	Digital/AS-I/IO-Link	IP66/IP67/IP69K	Cable/M12 plug	6 mm (¼")	No
ThinkTop V70	Open/closed	15-100	Yes/No	LED 360	Digital/AS-I/IO-Link	IP66/IP67/IP69K	Cable/M12 plug	6 mm (¼")	No
Type 8692	None	8-100	Yes	With display	Analogue 4-20 mA	IP65/IP67	Cable	6 mm (¼")	No
Type 8694	None	8-100	Yes	Without display	Analogue 4-20 mA	IP65/IP67	Cable	6 mm (¼")	No
Type 8697	None	8-100	Yes/No	LED	Digital	IP65/IP67	Cable	6 mm (¼")	Option

Note: Alfa Laval reserves the right to change specification without prior notice. Use the Alfa Laval Anytime configurator to identify possible variations.

# Handles

Alfa Laval Unique DV-ST UltraPure diaphragm valves are available with either composite or stainless steel handwheel. Selection is easy, simple and safe, meeting the demands of the pharmaceutical industry.

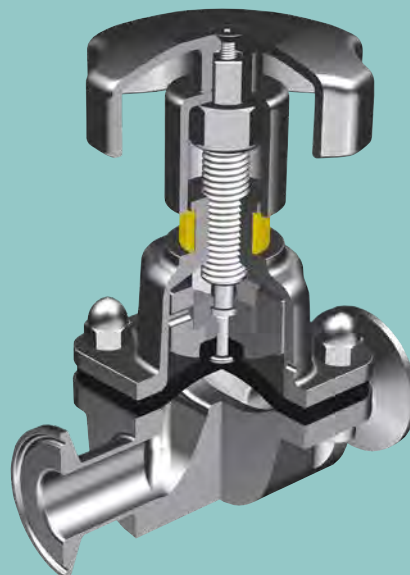

## Handles

Model	SS/SS	C/SS
Sizes	DN 8–100 (1/4"–4")	DN 8–100 (1/4"–4")
Handwheel	Stainless steel	Polyoxymethylene
Bonnet	Stainless steel	Stainless steel
Spindle and compressor	Stainless steel	Stainless steel
Max. product pressure	10 bar (145 psi)	10 bar (145 psi)
Max. temperature	150°C (302°F)	150°C (302°F)
Overclosure protection	Yes	Yes
Optical positioner	Yes	Yes
Lockable	No	No
Autoclavable	Yes	Yes <sup>1</sup>
Leakage detection	Yes	Yes

<sup>1</sup> 121°C (250°F) for max. 60 minutes.

Alfa Laval offers  
a complete range  
of handles for all  
sizes and types  
of valve bodies.

# Extending your equipment's performance

You can reach our global service partner wherever you are. We partner with you all the way – from start-up, maintenance and support, to improvements and monitoring services.

We help optimize your equipment to meet your evolving needs and secure uptime.

Using Alfa Laval genuine spare parts with Alfa Laval Q-doc documentation effectively protects the operational reliability of your plant and ensures the lowest total cost of ownership. We guarantee performance and provide an extended three-year warranty.

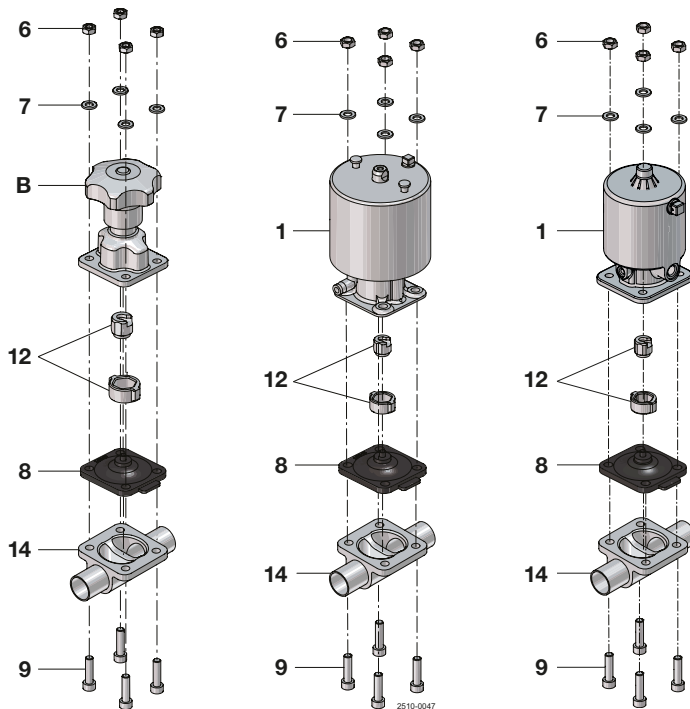

## Spare parts and service

All valve parts are readily available and easy to find in our spare parts catalogue on our website or in the instruction manual supplied together with the valve.

[www.alfalaval.com/high](http://www.alfalaval.com/high)

[www.alfalaval.com/service-and-support/service-overview](http://www.alfalaval.com/service-and-support/service-overview)

# Complete spare parts documentation

To facilitate safe and easy replacement of equal-to-equal spare parts, all our product contact parts come with complete Alfa Laval Q-doc documentation, providing evidence that all parts are of the same specification, design, and material, and are manufactured via the same standard operating procedures.

Clearly specified article numbers for spare parts and service kits in the original Q-doc valve documentation make it easy to order the correct spare parts for each

specific valve. Q-Doc for spare parts also clearly specifies part numbers, material quality, a Material Test Report for product-wetted steel parts, Compound ID and cure date for product-wetted, non-metallic materials, standard fulfilment and certification. Please check the diaphragm tab for size of new spare parts.

Overall, Q-doc secures the equal-to-equal spare parts replacement, simplifying change control procedures and providing customers with peace of mind.

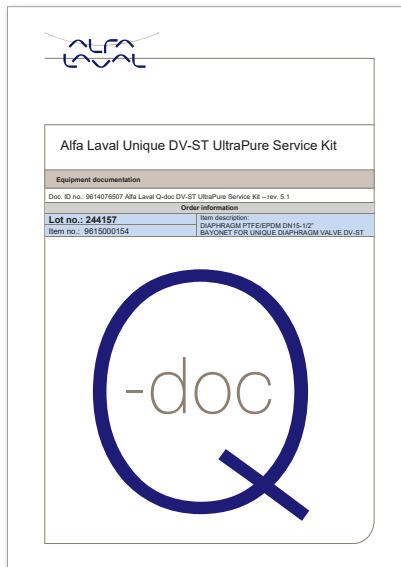

Q-Doc example for DV-ST service kit.

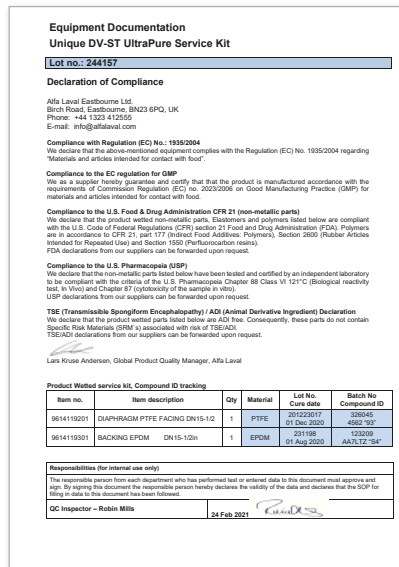

## Instruction manuals

All valves are delivered with instruction manuals for safe and correct installation, operation and maintenance. Instruction manuals are also available on our website.

Instruction manual example.

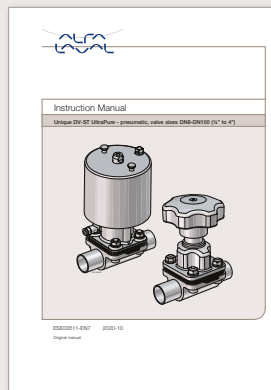

### Instruction manuals include:

- EC declaration of conformity
- General information
- Safety instructions
- Installation instructions
- Operation instructions
- Maintenance instructions
- Technical data
- Parts list and service kit information

# Pharma and biotech equipment overview

## Pumps

### Centrifugal pumps



LKH  
UltraPure



LKHex  
UltraPure



LKH Prime  
UltraPure



SolidC  
UltraPure



LKH



LKHex



LKH Prime

### Rotary lobe pumps



SX UltraPure



SX



SRU



OptiLobe

### Twin screw pump



Twin Screw

## Valves

### Diaphragm valves



Unique DV-ST  
UltraPure

### Double seat valves



Unique Mixproof  
UltraPure

### Single seat valves



Unique SSV

### Butterfly valves



LKB UltraPure

### Regulating, control, check valves and sampling valves



Unique  
RV-P



CPM-2



LKC  
UltraPure



Safety  
valves



Unique  
Sampling Valve

## Sensing and control units

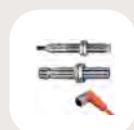

Indication  
sensor



IndiTop



ThinkTop  
D30



ThinkTop  
Basic



ThinkTop  
V50



ThinkTop  
V70



Type 8692



Type 8694



Type 8697

## Installation material



Tri-Clover  
UltraPure  
fittings



Tri-Clover  
UltraPure  
tubes

## Tank cleaning equipment

### Rotary jet heads



TJ SaniJet 20



TJ SaniJet 25



TJ 20G



TJ 40G

### Rotary spray heads



TJ SaniMidget



TJ SaniMidget  
SB UltraPure



TJ SaniMidget  
Retractor



SSB  
Retractor

### Cleaning validation instruments



Rotacheck Basic  
and Rotacheck+

## Agitators and mixers



LeviMag  
UltraPure



ALS



ALB



ALT



Hybrid  
Powder Mixer

## Tank accessories



Sight glasses  
and light fitting



Tank leg and  
base plate

## Tank covers



HLSD-2

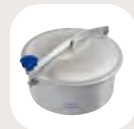

LKDC



LKD

## Heat exchangers

### Tubular heat exchangers



Point of Use



Pharma-line

### Gasketed plate heat exchangers



BaseLine

### Fusion-bonded plate heat exchangers



AlfaNova

### Welded heat exchangers



Compabloc



Spiral heat  
exchangers

## High-speed separators

### Biotech



Culturefuge



BTPX/BTUX



MBPX/MBUX

### Pharmaceutical



AB/ABPX



CHPX

### Single-use

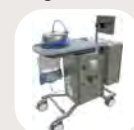

CultureOne

# Glossary

Term	Acronym	Definition
3A Sanitary Standards and Accepted Practice	<b>3A</b>	Determines criteria for the cleanability of dairy processing equipment. They have been adopted by many other liquid processing industries outside of dairy.
American Society of Mechanical Engineers	<b>ASME</b>	Creates consensus standards for Mechanical Engineering.
American Society for Testing and Materials	<b>ASTM</b>	Creates consensus standards for material quality and material quality testing methods.
BioProcessing Equipment Committee	<b>BPE</b>	An ASME sub-committee that creates engineering standards for the design, specification, manufacture and documentation of equipment used for biopharm processes.
Cleaning-in-Place	<b>CIP</b>	The technique of cleaning process line components without the need for relocation or disassembly.
Comité Européen de Normalisation	<b>CEN</b>	The European Committee for Standardization creates standards that reflect the best practices in each industry and is supported by DIN and ISO.
Current Good Manufacturing Practices	<b>cGMP</b>	Good manufacturing practice is that part of quality assurance which ensures that products are consistently produced and controlled to the quality standards appropriate to their intended use and as required by the marketing authorization.
Deionized water	<b>DIW</b>	Process of the extraction of deionized water through ion exchange resins.
Deutsches Institut für Normung	<b>DIN</b>	The German Institute for Standardization creates engineering standards for Germany and is a contributing body to CEN and ISO.
Electropolishing	<b>EP or E/P</b>	An electrochemical polishing process for metal components whereby metal ions are removed from the surface of the metal.
European Hygienic Engineering & Design Group	<b>EHEDG</b>	The group's objective is to provide standardization organizations (CEN and ISO) with specialist views on hygienic and aseptic design by publishing requirements and test methods. Accredited bodies carry out cleaning tests which are certified, if successful.
European Pharmacopoeia	<b>EP</b>	European counterpart to USP. A private, non-profit organization that sets standards for drugs, drug ingredients, medical devices and diagnostics.
Food and Drug Administration (U.S.)	<b>FDA</b>	Enforcement agency of the U.S. Government for food, drug and cosmetics manufacturing. Author of the U.S. cGMP's. Responsible for new product approvals, plant inspections and product recalls.
International Organization for Standardization	<b>ISO</b>	Creates consensus standards for engineering and quality systems.
Mill Test Report or Material Test Report	<b>MTR</b>	A document certifying the composition of a metal from a particular heat batch.
Piping and instrumentation diagram	<b>P&amp;ID</b>	American standard for process diagrams upon which the process, the instruments and the flow scheme are defined.
Point of Use	<b>POU</b>	A valve outlet in a recirculation utility system (typically a water system).
Purified water	<b>PW</b>	Ingredient water (not for injection) or rinse water for pharmaceutical products conforming to USP guidelines. Obtained by distillation, reverse osmosis, ion exchange or any other suitable process.
Steam-in-Place	<b>SIP</b>	Sanitization of process line components by the use of steam without the need for relocation or disassembly.
Total Oxidizable Carbon or Total Organic Carbon	<b>TOC</b>	A measure of the amount of organic compounds in a water sample. Carbon is oxidized and the level of CO <sub>2</sub> is measured. The proposed USP water standards are based on TOC analysis.
United States Pharmacopoeia	<b>USP</b>	A private, non-profit organization that sets standards for drug, drug ingredients, medical devices, and diagnostics. The FDA enforces the established standards.
Water for injection	<b>WFI</b>	Water for use as a solvent for the preparation of parenteral products confirming to USP guidelines. Obtained most commonly by distillation.



Through years of innovation, improvement and refinement, Alfa Laval has consistently delivered high-performance equipment backed by thorough documentation.



### This is Alfa Laval

Alfa Laval is active in the areas of Energy, Marine, and Food & Water, offering its expertise, products, and service to a wide range of industries in some 100 countries. The company is committed to optimizing processes, creating responsible growth, and driving progress – always going the extra mile to support customers in achieving their business goals and sustainability targets.

Alfa Laval's innovative technologies are dedicated to purifying, refining, and reusing materials, promoting more responsible use of natural resources. They contribute to improved energy efficiency and heat recovery, better water treatment, and reduced emissions. Thereby, Alfa Laval is not only accelerating success for its customers, but also for people and the planet. Making the world better, every day. It's all about *Advancing better™*.

100001224-3-EN 2109



[www.sks-online.com](http://www.sks-online.com)

