

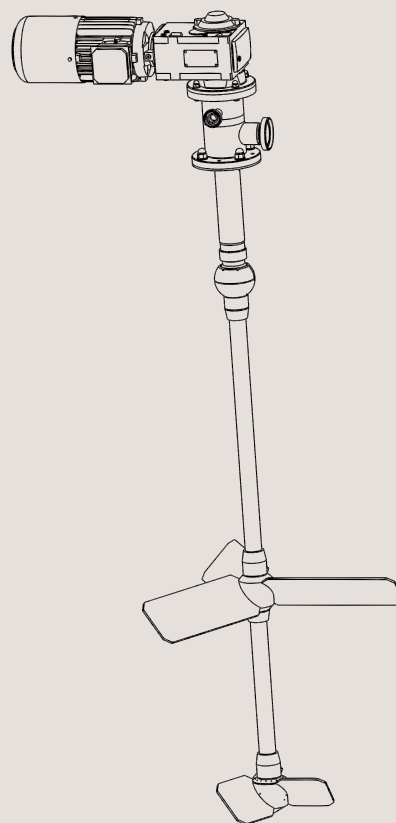

Instruction Manual

ALT-SB-15



100000242-EN3

2020-05

Original manual



www.sks-online.com

The information herein is correct at the time of issue but may be subject to change without prior notice

1. EC Declaration of Conformity	4
2. Safety	5
2.1. Important information	5
2.2. Warning signs	5
2.3. Intended use	5
2.4. Safety precautions	6
3. Installation	7
3.1. Unpacking/delivery	7
3.2. Requirement for installation, personnel	8
3.3. Installation, welding and mechanically	9
3.4. Installation, electrically	15
3.5. Recycling information	15
4. Operation	16
4.1. General information	16
4.2. Aeration	16
4.3. Inspection	17
4.4. Troubleshooting	17
4.5. Cleaning	18
5. Maintenance	20
5.1. General maintenance	20
5.2. Disassembling of Agitator	21
5.3. Assembling of Agitator	28
5.4. Replacement of gear motor	29
5.5. Replacement of seals	29
6. Technical Data	30
6.1. ALT-SB-15, With Aeration (item number 9614322301)	30
6.2. ALT-SB-15, Without Aeration (item number 9614328901)	31
7. Parts list/Service kits	32
7.1. ALT-SB-15, with aeration	32
7.2. ALT-SB-15, without aeration	34
7.3. ALT-SB-15, with and without aeration	36
7.4. Accessories	40
7.5. Installation drawing	42
8. Appendix	43
8.1. Declaration of Compliance	43
8.2. Order specific "Tank With Agitator" drawing, example	44
8.3. Drive Unit lubrication	45
8.4. Drive Unit instructions	50

1 EC Declaration of Conformity

Revision of Declaration of Conformity: 2018-01-01

The Designated Company

Alfa Laval Kolding A/S

Company Name

Albuen 31, DK-6000 Kolding, Denmark

Address

+45 79 32 22 00

Phone No.

hereby declare that

ALT-SB

Designation

15

Type

Serial number from AAC000000001 to AAC999999999

is in conformity with the following directive with amendments:

**Machinery Directive 2006/42/EC
FDA 21CFR§177
Regulation (EC) 1935/2004**

The person authorised to compile the technical file is the signer of this document.

Global Product Quality Manager, Pumps, Valves, Fittings and Tank Equipment

Title

Lars Kruse Andersen

Name

Kolding

Place

2020-01-01

Date (YYYY-MM-DD)

Signature



*Unsafe practices and other important information are emphasized in this manual.
Warnings are emphasized by means of special signs.*

2.1 Important information

Always read the manual before using the Agitator!

WARNING

Indicates that special procedures must be followed to avoid serious personal injury.

CAUTION

Indicates that special procedures must be followed to avoid damage to the Agitator.

NOTE

Indicates important information to simplify or clarify procedures.

2.2 Warning signs

General warning:



Caustic agents:



Dangerous electrical voltage:



2.3 Intended use

- The Agitator is only for mixing/conditioning/stirring of liquids in a tank.
 - The Agitator is only made for top mounting position on the top plate/welding flange on the tank.
-

2 Safety

All warnings in the manual are summarised on this page.

Pay special attention to the instructions below so that serious personal injury and/or damage to the Agitator are avoided.

2.4 Safety precautions

2.4.1 Installation:

Always read the technical data thoroughly (see chapter 6 Technical Data).

Always follow installation instructions thoroughly (see chapter 3 Installation).

Never expose the Agitator to undue vibrations or shocks.

Never start the Agitator in the wrong direction of rotation.

Ensure that the tank media is not corrosive to the Agitator.

Only install the Agitator in environments within temperature limit: -20°C and +40°C.

Only install the Agitator in altitudes less than 1000 m above sea level.

Only use authorized personnel when electrically equipment is connected.



2.4.2 Operation:

Always read the technical data thoroughly (see chapter 6 Technical Data).

Never start Agitator in the wrong direction of rotation.

Beware of Agitator in operation can produce sound levels in excess of 85dB(A).

Always handle lye and acid with great care.

Always rinse well with clean water after cleaning.

Never run the Agitator for a longer time (seconds) without product, water or cleaning liquid in the tank.



2.4.3 Maintenance:

Always follow the maintenance instruction thoroughly (see chapter 5 Maintenance.)

Always follow the maintenance instruction for gear motor thoroughly (see section 8.4 Drive Unit instructions).

Always study the parts list and assembly drawing carefully (see chapter 7 Parts list/Service kits).

Never touch the moving parts while the Agitator is connected to the power supply.

Always disconnect the power supply while servicing the Agitator.

Ensure correct rotation direction of propeller before startup and after any maintains there might have impact on the direction.

Never service the Agitator or tank with product or cleaning liquid in the tank.



2.4.4 Transportation:

Always transport the Agitator in original packaging.

Always support the shaft adequately, to protect shaft and bearings.

Never expose the Agitator to undue vibrations or shocks.

Control for oil leakage on gears with vent screw.

Ensure correct rotation direction of impeller before startup and after any maintenance which might have impact on the direction.

*The instruction manual is part of delivery. Study the instructions carefully.
The Agitator is for permanent fastening.
Make sure the motor corresponds to the environment.
Check the direction of rotation before operation.*

3.1 Unpacking/delivery



Always use lifting equipment when handling the Agitator.
Alfa Laval cannot be responsible for incorrect unpacking.

Step 1

Inspect the delivery for visible transportation damage (crates and packaging) - all issues should be reported to carrier.

Step 2

Check that deliveries are according to delivery notes.
Complete Agitators can be delivered in more than one shipment.

Step 3

Inspect Agitator parts for visible transport damage.

Step 4



Do NOT use eye bolts on gear motor to lift the Agitator. They are only for gear motor removal.

Step 5

During lifting:

- Always support the shaft adequately to protect shaft and bearings.
- Be carefully not to damage shaft-end with treads.
- Never expose the Agitator to undue vibrations or shocks.
- Control for oil leakage on gears – leave vent plug in gear until gear is installed and in correct position (see Figure 1).

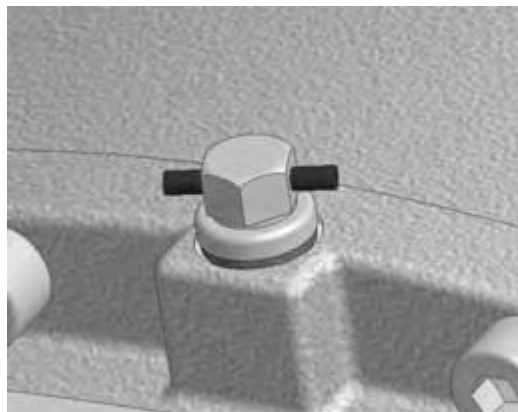

Figure 1, un-activated vent plug

3 Installation

*The instruction manual is part of delivery. Study the instructions carefully.
The Agitator is for permanent fastening.
Make sure the motor corresponds to the environment.
Check the direction of rotation before operation.*

3.2 Requirement for installation, personnel

Erectors:

- Experience from similar types of installation.
- Proven skills in reading installation guidelines and drawings ensuring that the installation is carried out safe for personnel and property.



Electrician:

- Certified according to local regulations and experience from similar types of installation.
- Proven skills in reading installation guidelines and drawings ensuring that the installation is carried out safe for personnel and property.



Welder:

- Experience from similar types of installation, covering TIG, MIG and MAG welding procedures in stainless steel thin walled material.
- Proven skills in reading installation guidelines and drawings ensuring that the installation is carried out safe for personnel and property.



All position numbers and item numbers refer to the drawings show and specified in chapter 7 Parts list/Service kits.

3.3 Installation, welding and mechanically

3.3.1 Requirement for installation

This work should be carried out by at least two persons and for safety reasons a platform or a scaffold should be established around the tank top.

During installation ensure to use sufficient lightning.

The tank top must be horizontally during installation.



Ensure that the tank does not contain neither dangerous liquid nor gasses and that good ventilation is established.

Always have safety elements removed by authorized personnel.

Never cover or remove nameplates.

Always use lifting equipment when handling heavy parts of the Agitator.



Never connect to power during installation.

Always have the Agitator connected to power supply by authorized personnel.



NOTE

Alfa Laval highly recommend installing motor protection guard and a soft starter, or a frequency converter, with a start ramp up time of 2-7 sec. to the Agitator.

All position numbers and item numbers refer to the drawings show and specified in chapter 7 Parts list/Service kits.

3 Installation

All position numbers and item numbers refer to the drawings show and specified in chapter 7 Parts list/Service kits.

All position numbers and item numbers refer to the drawings show and specified in chapter 7 Parts list/Service kits.

Step 1

3.3.2

1. The complete assembled drive unit comes with loose connections for Aeration (28) and connections for CIP (27) depending on actual delivery (see section 4.2 Aeration and section 4.5 Cleaning). The tubes for both types of the connections are delivered with protection plugs ensuring that no debris or the likes are left in the sealing system of the Agitator during freight and installation. It must be decided if the delivered connections are the right types to the actual installation – if not other connections have to be acquired before they can be welded onto the tubes.
2. Fasten the complete drive unit in a work bench enable good welding work conditions to be carried out.
3. Remove the protection plugs and insert another temporary type of protection inside the tube (textile or the like) ensuring that no debris are left inside the sealing system during the welding process.
4. Weld on the required connections to the tubing using as less introduced heat as possible.
5. Grind and clean the weldings before removing the temporary protection inside the tubes.

Step 2

3.3.3

1. Clean shaft and propeller threads for grease.
2. The propellers and shafts can be assembled outside the tank if the size of the top flange (99) and the head room above the tank is sufficiently – otherwise the shaft and propeller unit must be assembled inside the tank. The shaft and propeller unit can consist of two shafts and two propellers or of one shaft and one propeller – see actual order specific drawing – example shown in section 8.2 Order specific “Tank With Agitator” drawing, example.
3. Assemble the shafts, propellers, gaskets, O-rings and Loctite: Position 2, 3, 4, 32, 34, 29.
4. Apply Loctite to the threads and tighten to 100-300 Nm.
5. Screw on the lifting eye tool (51) onto the upper shaft part (3) and lift the shaft and propeller unit using a hoist with a sling.

3 Installation

All position numbers and item numbers refer to the drawings show and specified in chapter 7 Parts list/Service kits.

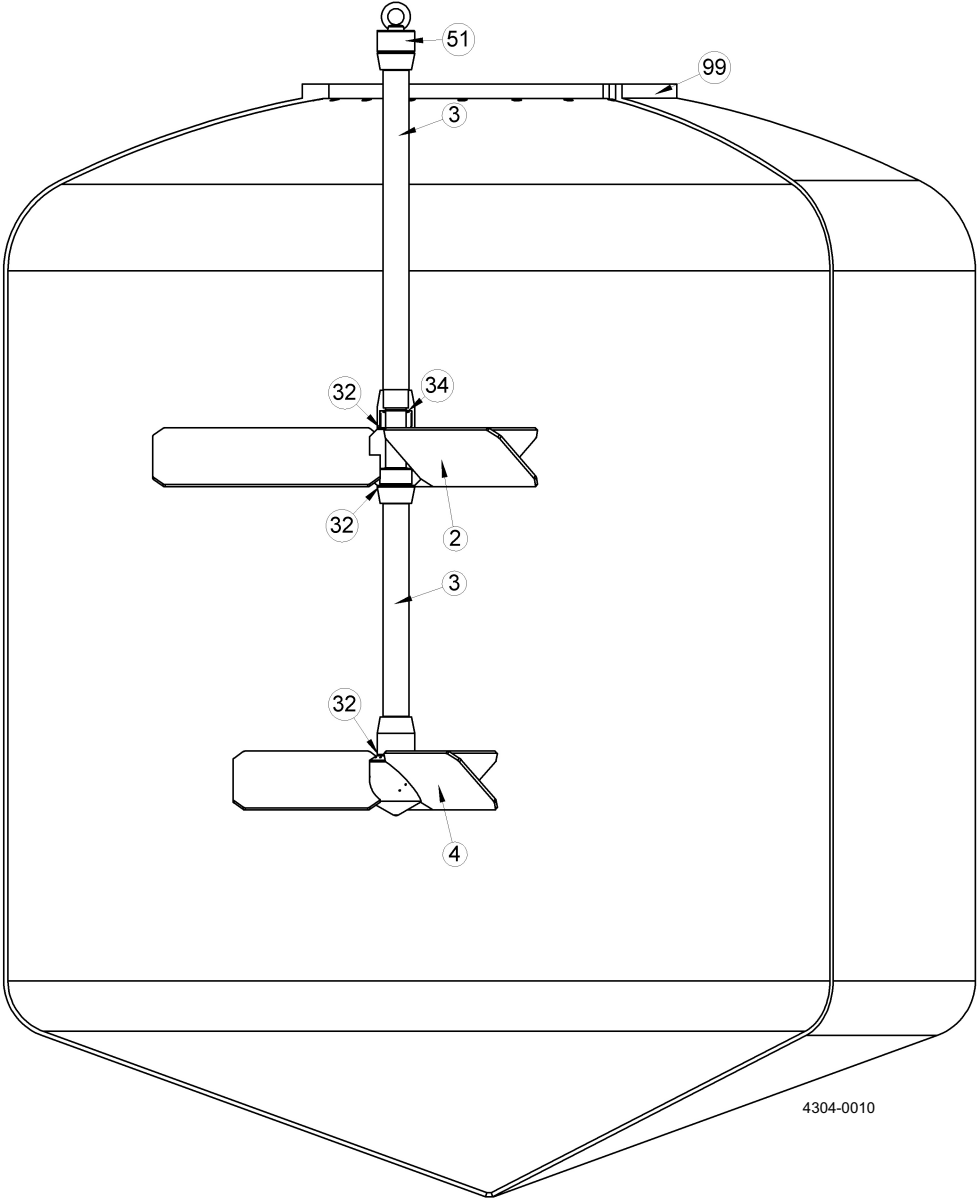

3 Installation

All position numbers and item numbers refer to the drawings show and specified in chapter 7 Parts list/Service kits.

Step 3

3.3.4

1. Having the shaft and propeller assembly positioned in the tank a second sling is attached to the lifting eye (51) and that second sling is pulled through the top plate (100) (which has the welding flange for the Agitator (60) welded into it).
2. Using the second sling the shaft and propeller assembly can be positioned and secured at the top of the welding flange (60) using the fastener tool (50) (see section 7.4 Accessories, Mounting tools). Remember to have the gasket (101) positioned correctly.
3. Unscrew the lifting tool (51) from the shaft and propeller unit and store it.

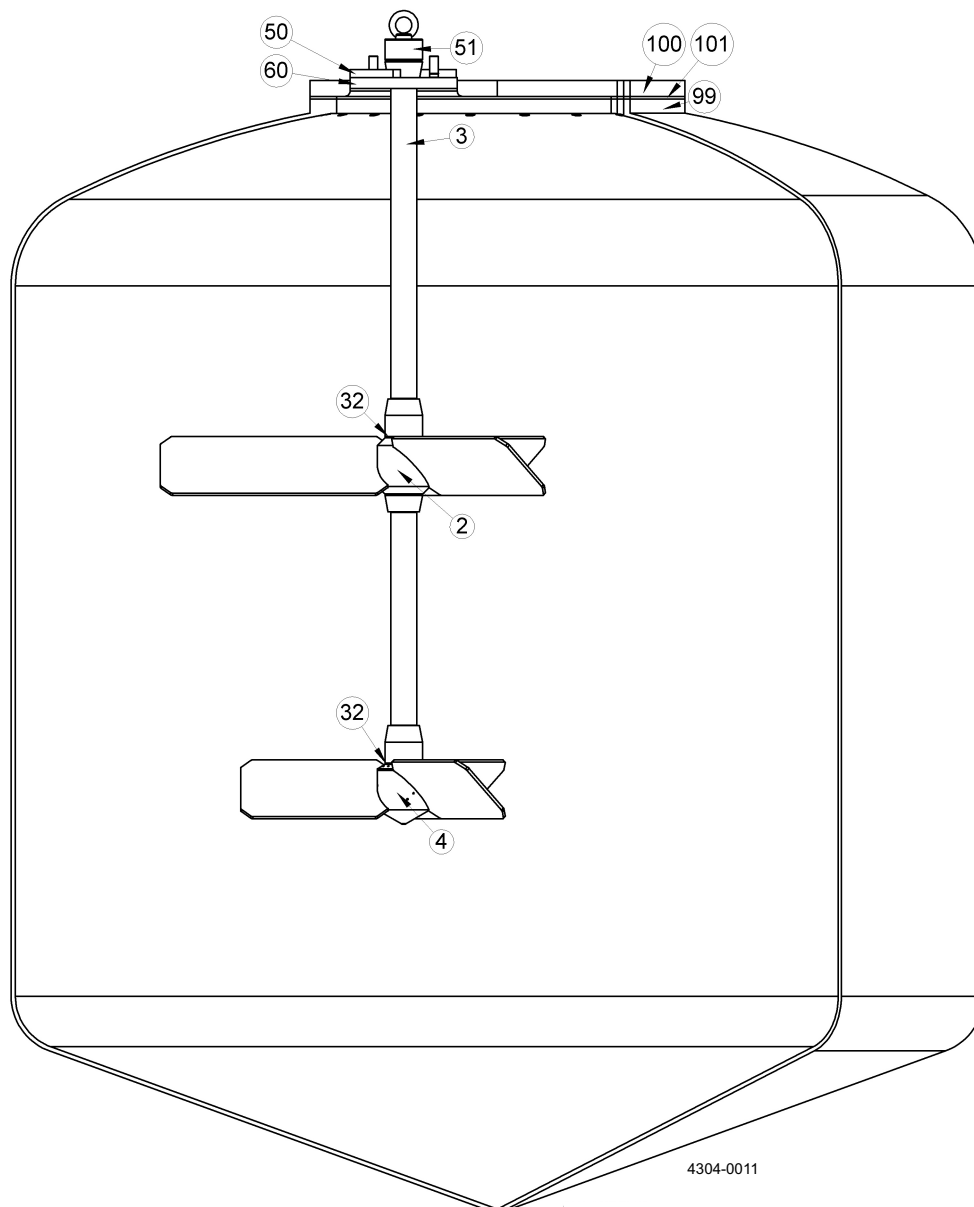

4304-0011

3 Installation

All position numbers and item numbers refer to the drawings show and specified in chapter 7 Parts list/Service kits.

Step 5

3.3.6

1. The oil vent plug is activated on the gear motor (see Figure 2 and optionally section 8.4 Drive Unit instructions).

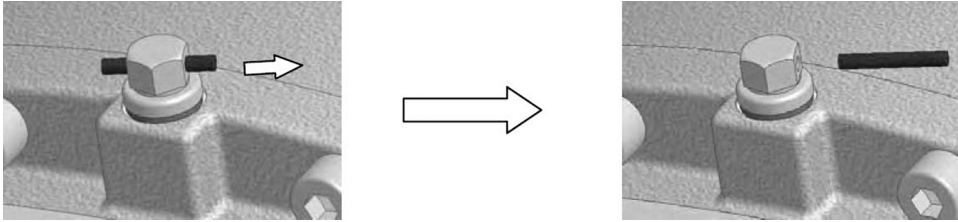
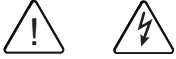

Figure 2, Activation of gear vent plug

*The instruction manual is part of delivery. Study the instructions carefully.
The Agitator is for permanent fastening.
Make sure the motor corresponds to the environment.
Check the direction of rotation before operation.*

3.4 Installation, electrically



- Operation by unauthorized personnel may endanger personnel and property.
- Treat all electrical equipment as powered.
- Switch off the power before maintenance and repair.
- The electrician must be certified according to local regulations and with at least 3 years' experience from similar types of installations.
- The electrician must have proven skills in reading and working from drawings and cable lists.
- The electrician must have knowledge of local safety regulations for power and automation and making sure that any work carried out is safe for personnel and property before the equipment is put back into operation.

If you need assistance or have questions – please contact Alfa Laval.

- The motor requires the power supply as indicated on the name plate.
- It is recommended to secure the motor with a motor protection.
- We recommend starting the motor by use of a soft starter, or a frequency converter, with a start ramp up time of 2-7 sec.
- We recommend installation of a service switch at the Agitator to secure the personnel during service work.
- Perform a visual inspection of the direction of rotation. The direction required is indicated on the name plate.



- Rotation of Agitator must be clockwise looking from the tank top and down. Otherwise the Agitator will be damaged.

3.5 Recycling information

• Unpacking

- Packing material consists of wood, plastics, cardboard boxes and in some cases metal straps.
- Wood and cardboard boxes can be re-used, recycled or used for energy recovery.
- Plastics should be recycled or burnt at a licensed waste incineration plant.
- Metal straps should be sent for material recycling.

• Maintenance

- During maintenance, oil and wear parts in the machine are replaced.
- All metal parts should be sent for material recycling.
- Worn out or defective electronic parts should be sent to a licensed handler for material recycling.
- Oil and all non-metal wear parts must be disposed of in accordance with local regulations.

• Scrapping

- At the end of use, the equipment must be recycled according to the relevant, local regulations. Besides the equipment itself, any hazardous residues from the process liquid must be considered and dealt with in a proper manner. When in doubt, or in the absence of local regulations, please contact your local Alfa Laval sales company.
-

4 Operation

Study the instructions carefully and pay special attention to warnings! Always check the Agitator before operation. Alfa Laval recommends a soft starter for the Agitator to reduce the load on tank and Agitator.
All position numbers and item numbers refer to the drawings shown and specified in chapter 7 Parts list/Service kits.

4.1 General information



Rotation of Agitator must always be clockwise.
Use of gear motor covers is not permitted due to risk of reduced cooling on motor.

If batch rotation is observed during operation, the optimum effect of the Agitator is achieved by interval agitation instead. If interval agitation is used, the gear motor must be installed with a soft-starter or a frequency converter to increase gear motor life time and reduce forces on the tank top system.
If a sensitive product is processed, agitation speed and time should be reduced as much as possible.
If the Agitator is equipped with an aeration valve, it is possible to aerate the product through the shaft during the agitation.

4.2 Aeration

If Agitator is equipped with Aeration feature the upper connection (28) can be used letting in sterile air into the batch through the inside of the shafts and out at the lower propeller. The flow versus pressure can be calculated from the formula described in chapter 6 Technical Data.

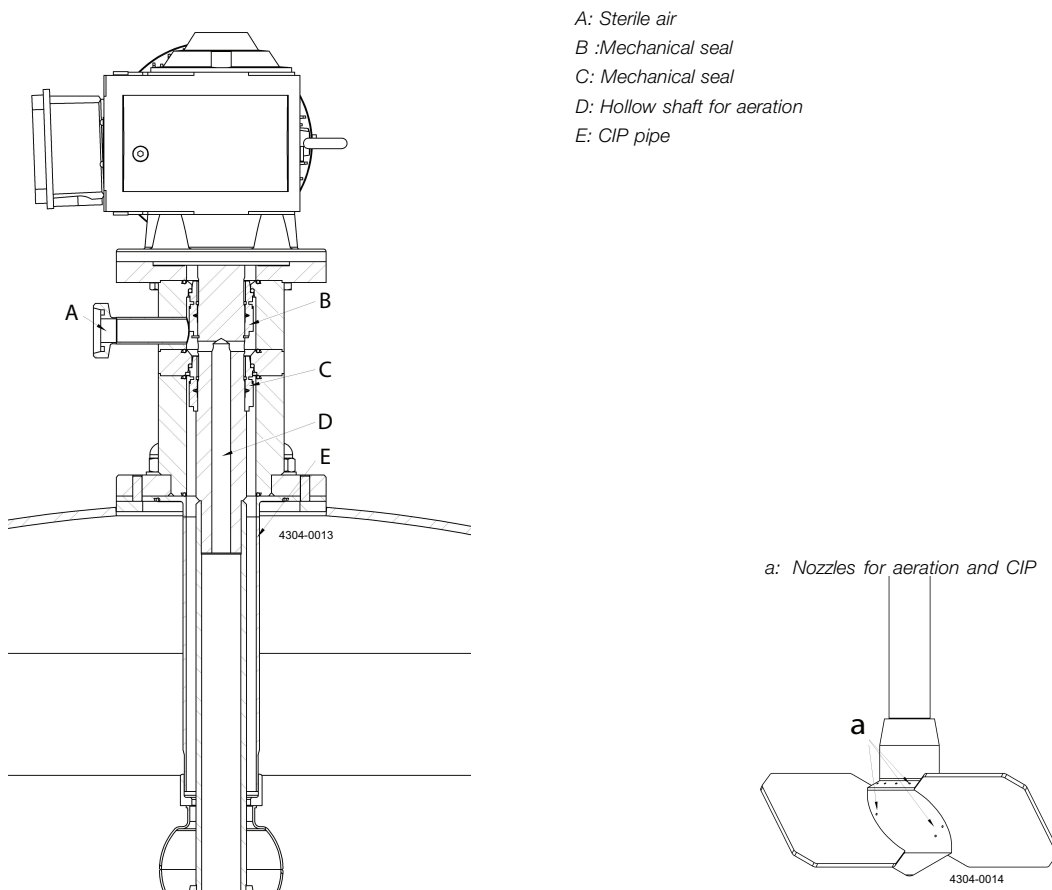

Study the instructions carefully and pay special attention to warnings! Always check the Agitator before operation. Alfa Laval recommends a soft starter for the Agitator to reduce the load on tank and Agitator.
All position numbers and item numbers refer to the drawings shown and specified in chapter 7 Parts list/Service kits.

4.3 Inspection

Part	Inspection Interval
Gear motor - Clean surfaces to avoid overheating - Check for oil leakages	Monthly Monthly
Sealing - Verify that the seals are not leaking	Monthly

4.4 Troubleshooting

Problem	Cause/result	Remedy
Not starting		
Gear motor	- Defect	- Dismantle gear motor, check for correct rotation - Replace gear motor
	- Fault at power supply	- Check power supply connection - Check voltage and frequency correspond with motor name plate - Check frequency converter adjustment correspond with motor name plate
Agitator	- Obstructed	- Check that Agitator can rotate freely without striking anything
Vibrations		
Propeller	- Damaged - Unbalanced	- Contact Alfa Laval - Clean propeller
Shaft	- Damaged	- Contact Alfa Laval
Unusual sounds		
	- Find root cause of sound	- Change and/or repair parts
Leakage		
Gear motor	- Oil leakage - CIP fluid or other from drain	- Renovate or change gear motor - Replace sealing
Performance		
	- Deviation from normal operation	- Operation must be according to specification

4 Operation

Study the instructions carefully and pay special attention to warnings! Always check the Agitator before operation. Alfa Laval recommends a soft starter for the Agitator to reduce the load on tank and Agitator.
All position numbers and item numbers refer to the drawings shown and specified in chapter 7 Parts list/Service kits.

4.5 Cleaning

4.5.1 General Information



The Agitator is fitted with a rotating spray ball designed to clean Agitator and tank as part of the same cleaning process (Cleaning In Place - CIP).

The lower propeller is equipped with nozzles cleaning all down facing propeller blades (both lower and upper - if included) – up facing propeller blades are cleaned by the spray ball.

Cleaning requires CIP fluids to be connected to (27 and 28) if with Aeration and (27) only if without Aeration.

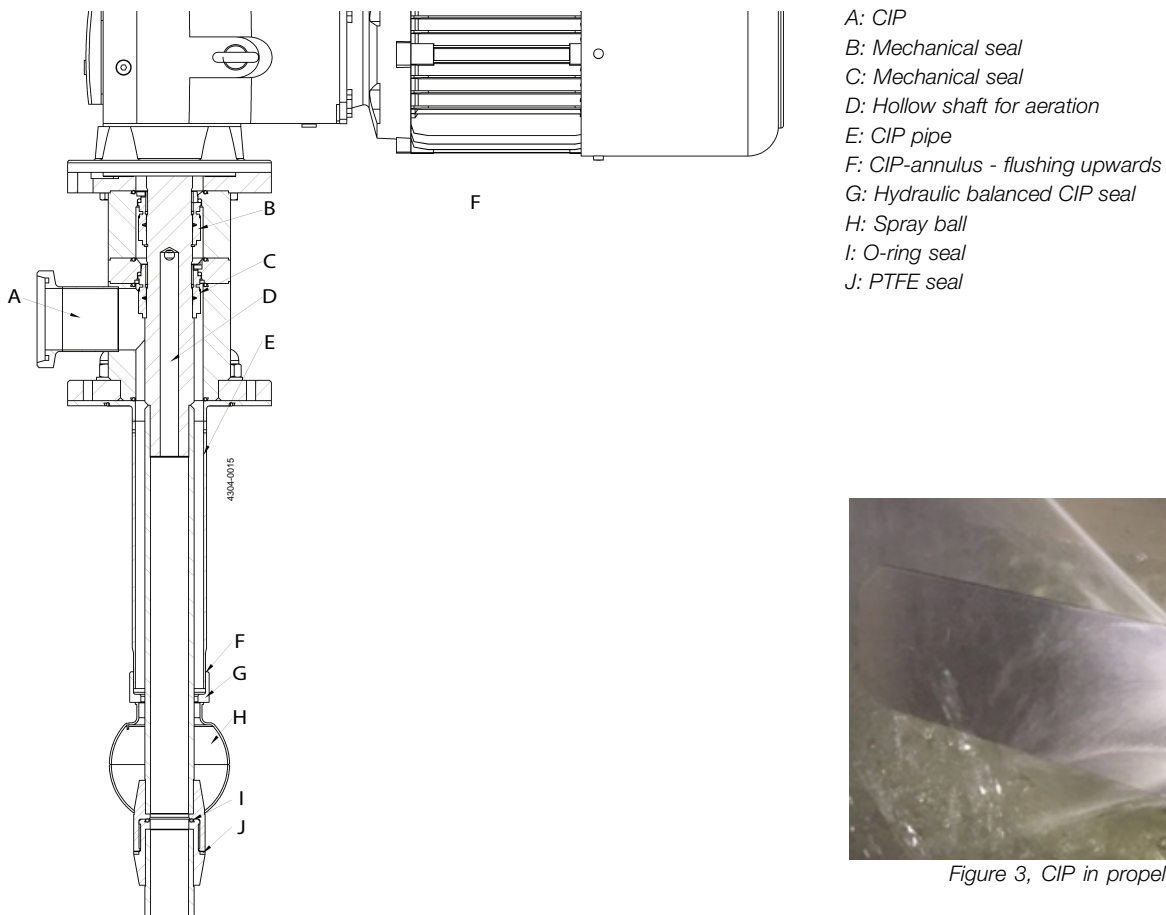

The Agitator does not require a special cleaning procedure but the process can be integrated in the usual tank cleaning concept. However, hot caustic cleaning is always recommended.

*Study the instructions carefully and pay special attention to warnings! Always check the Agitator before operation. Alfa Laval recommends a soft starter for the Agitator to reduce the load on tank and Agitator.
All position numbers and item numbers refer to the drawings shown and specified in chapter 7 Parts list/Service kits.*

NOTE

The Agitator must not be run at temperatures above 90°C.

Ensure that all surfaces in contact with product are totally clean so product is not contaminated and that the Agitator itself is not exposed pit corrosion.

Pay special attention to:

- Impeller device surfaces.
- Surfaces between propellers and shaft.
- Surfaces around sealing and bushings.
- Surfaces around weldings.



4.5.2 Cleaning examples

- CIP fluids to be connected to CIP connection (27 and 28) if with Aeration and (27) only if without Aeration.
 - Pre-rinse with cold water for approximately 3-5 minutes.
 - The caustic cleaning step should be made with hot caustic 60-70°C 30 - 45 minutes.
 - The yeast mixer should be running continuously during CIP.
 - The recommended CIP flows versus pressures can be calculated from the formula in section 6.1 ALT-SB-15, With Aeration (item number 9614322301) and 6.2 ALT-SB-15, Without Aeration (item number 9614328901).
 - The cleaning should be made as soon as possible after emptying the tank, while the inside surfaces are still wet.
 - Final-rinse with hot water for approximately 3 minutes followed by cold water for 3-5 minutes or until last rinsing water is free from chemicals.
-

5 Maintenance

Ensure totally clean surfaces during mounting. Always use original Alfa Laval parts.

If product wetted parts are soiled during de-commissioning or installation, these must be manually cleaned prior commissioning of the equipment.

5.1 General maintenance



- Maintenance of the Agitator should only be performed by authorized personnel.
- For maintenance instructions of gear motor please see section 8.3 Drive Unit lubrication.
- Ensure totally clean surfaces during maintenance.
- For lifting instruction, please see chapter 3 Installation.
- Always disconnect the power supply when servicing the Agitator.
- Always use proper tools.
- Always replace worn sealing elements before reassembling.
- Follow the dismantling and assembly instructions to the letter.
- All scrap must be stored/disposed of in accordance with current rules and directives.
- Always use original Alfa Laval spare parts.

Part	Replace every
Sealing (Mechanical, PTFE and O-rings)	3000 hours or 2 nd year

All position numbers and item numbers refer to the drawings shown and specified in chapter 7 Parts list/Service kits.

5.2 Disassembling of Agitator

Step 1

5.2.1

- 1. Unscrew the four nuts (16) and remove the washers (17).

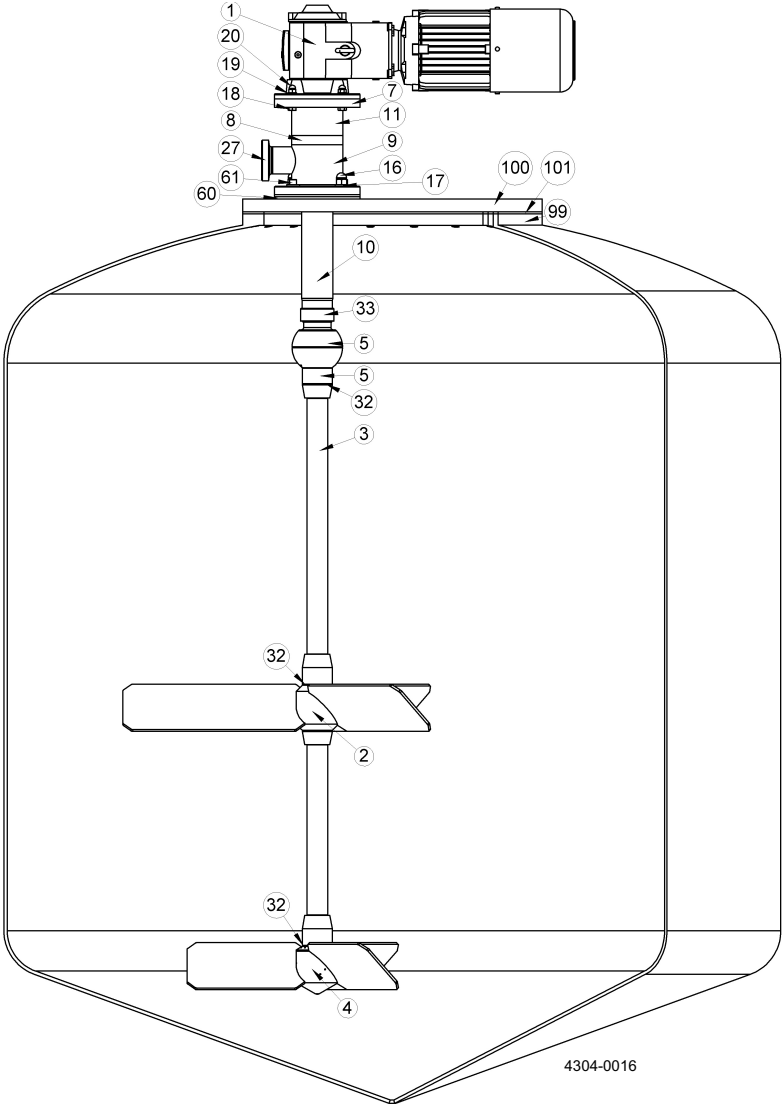

5 Maintenance

All position numbers and item numbers refer to the drawings shown and specified in chapter 7 Parts list/Service kits.

Step 2

5.2.2

1. Lift the complete Agitator using a hoist and a sling (do not use lifting eye on the gear motor).

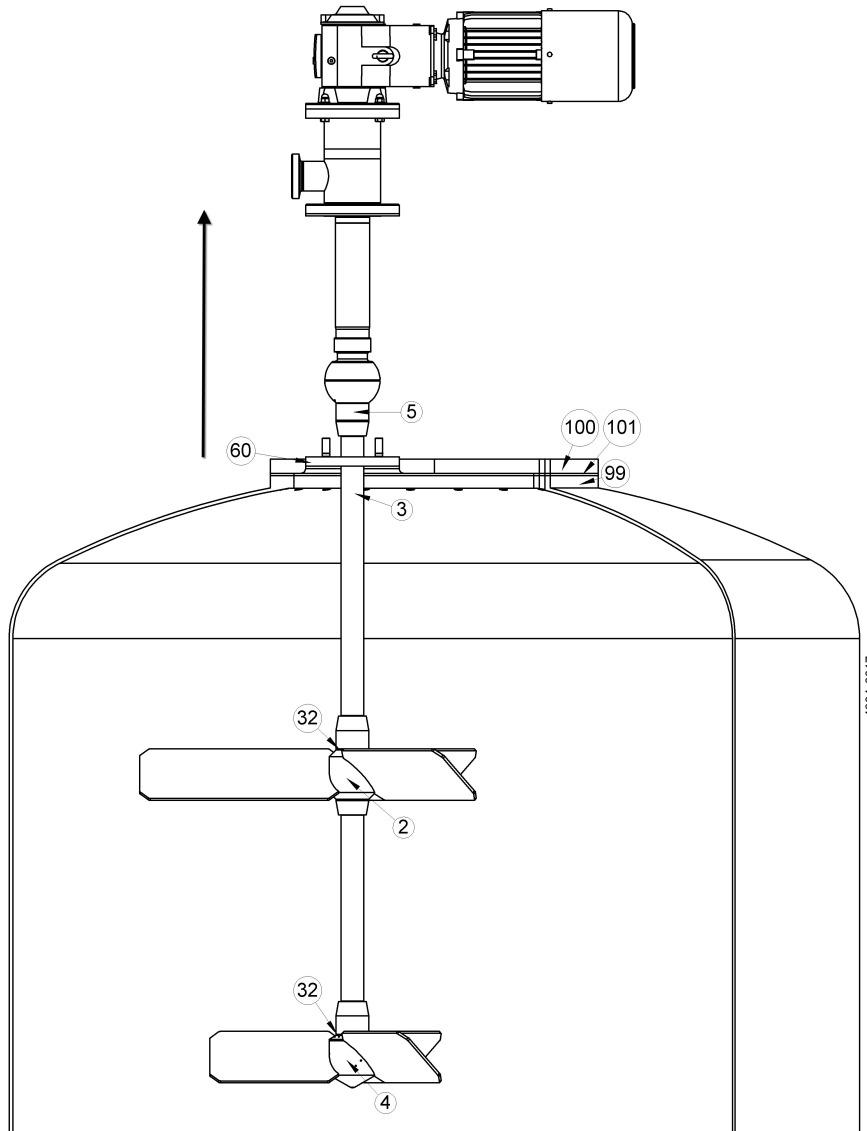

All position numbers and item numbers refer to the drawings shown and specified in chapter 7 Parts list/Service kits.

Step 3

5.2.3

1. Insert the fastener tool (50) onto the welding flange (60) and unscrew the threaded connection between the shaft (3) and the shaft (5). The thread is original tightened using Loctite – coated abrasive around the pipe, together with an appropriated pipe wrench, can be used to unscrew the connection without damaging the surfaces.
2. Position the shaft and propeller unit into the fastener tool (50) and lift down the complete drive unit into an appropriated workshop where service can be carried out.

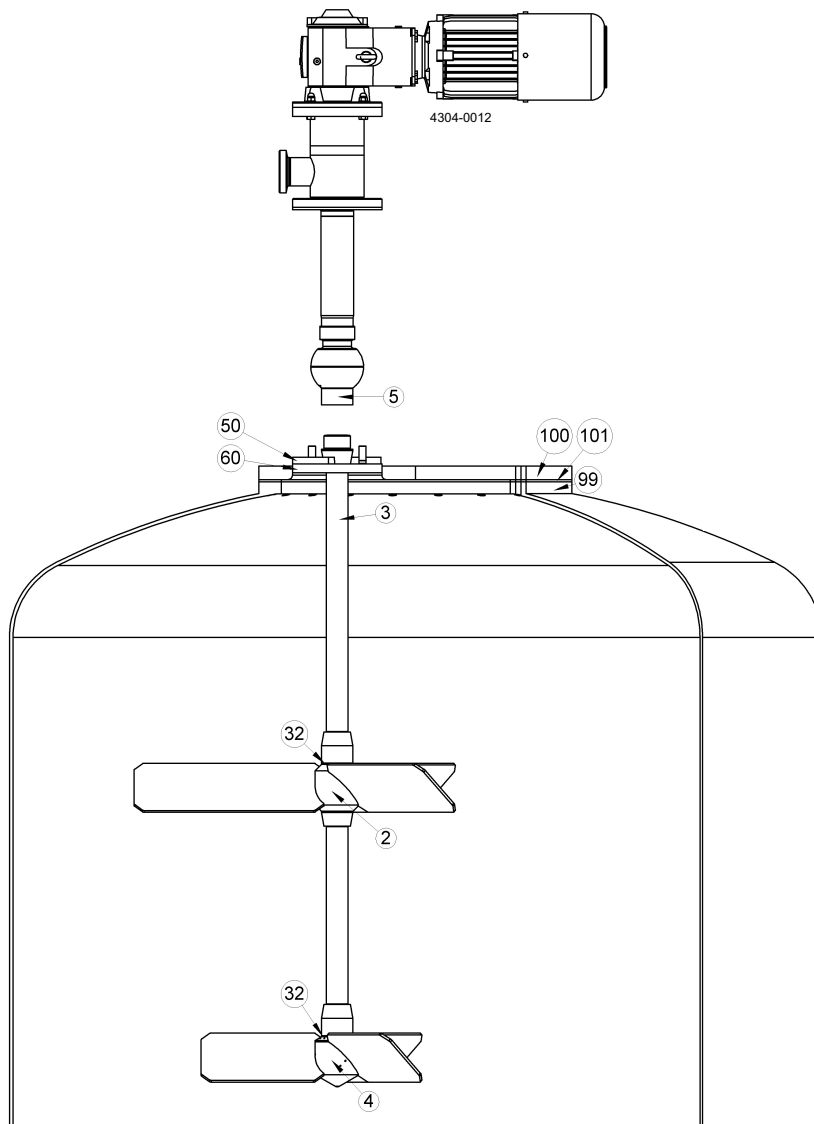

5 Maintenance

All position numbers and item numbers refer to the drawings shown and specified in chapter 7 Parts list/Service kits.

Step 4

5.2.4

1. The complete drive unit is secured vertically to a table (or the like) (200) with a hole enabling the shaft (5) to point vertically down and to be secured vertically (201) in the correct distance (438 ± 2 mm).
2. The gear motor screw cover (1A) is removed.
3. The screw (21) is unscrewed from the shaft (5).
4. The washer (22), which consists of two parts attached to each other with some silicone, is removed. It is important that the parts are positioned as shown on Figure 4 when assembled.
5. The bushing that follows the gear motor seen on Figure 5 (together with position 21 and position 22) is removed and the surfaces between the shaft (5) and the hollow shaft of the gear motor 1 is lubricated using some thin oil – that eases the disassembling of the two parts.
6. The fasteners (18, 19 and 20) is unscrewed (during assembly they must be tightened sequentially to 51 Nm using some Loctite).
7. The gear motor (1) is carefully lifted. It is important that the shaft (5) is not bumped hard from side to side as the shaft surfaces collide easily with the fragile mechanical seal parts (30).

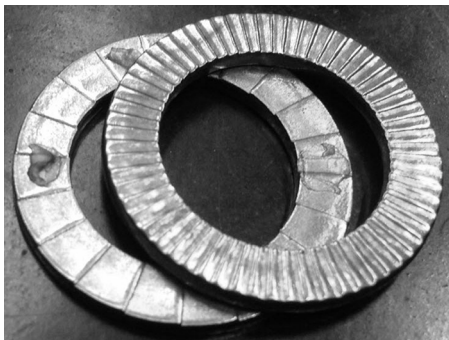
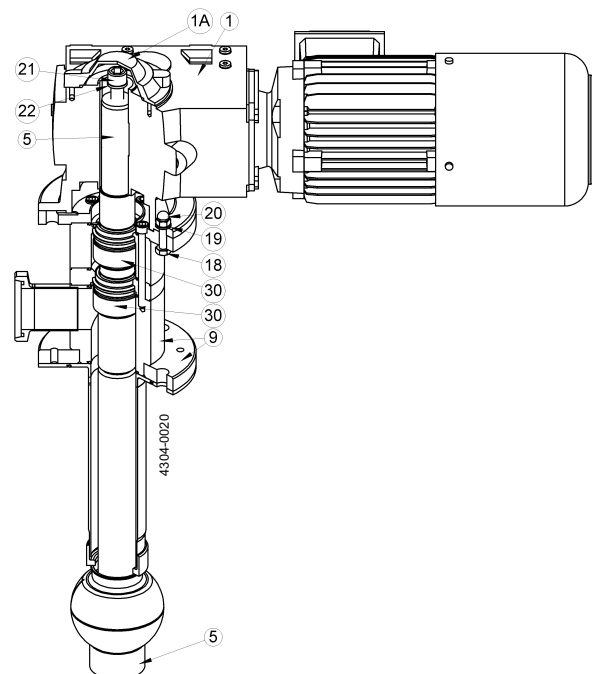
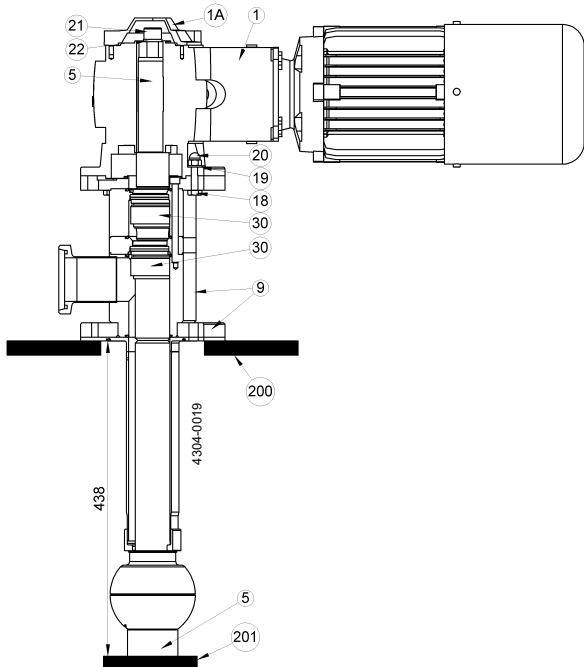

Figure 4, One washer (22)



Figure 5, Bushing for shaft and gear motor



All position numbers and item numbers refer to the drawings shown and specified in chapter 7 Parts list/Service kits.

Step 5

5.2.5

1. The screws (24) are unscrewed (during assembly they must be tightened sequentially to 51 Nm using some Loctite).
2. The flange (7) is removed.

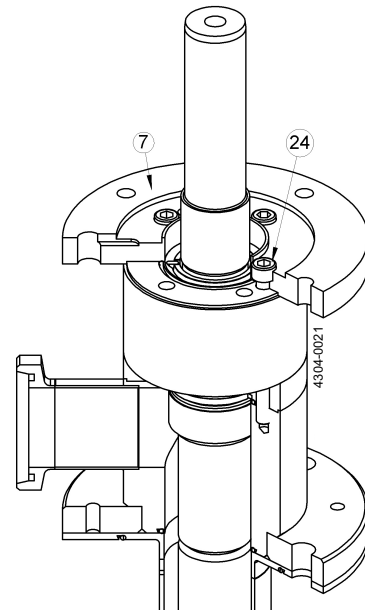

Step 6

5.2.6 (only for type with Aeration - item number 9614322301)

1. The gear console (7) is removed as one part together with: pins (13), O-ring (36) and the stationary part of the mechanical seal (30A) (including O-ring).

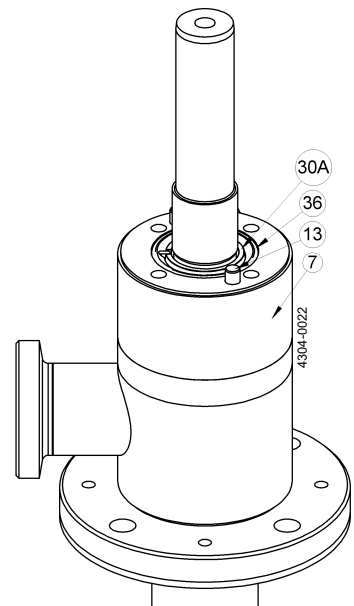

5 Maintenance

All position numbers and item numbers refer to the drawings shown and specified in chapter 7 Parts list/Service kits.

Step 7

5.2.7 (only for type with Aeration - item number 9614322301)

1. Remove the PTFE sliding part of the rotating part of the seal (30B).
2. Add some grease to the shaft and pull up the rotating part of the seal (30B).
3. Remove the circlip (15).

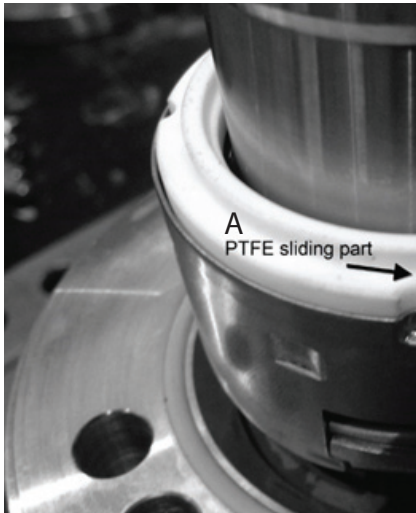

A: PTFE sliding part

Figure 6, PTFE sliding part of seal

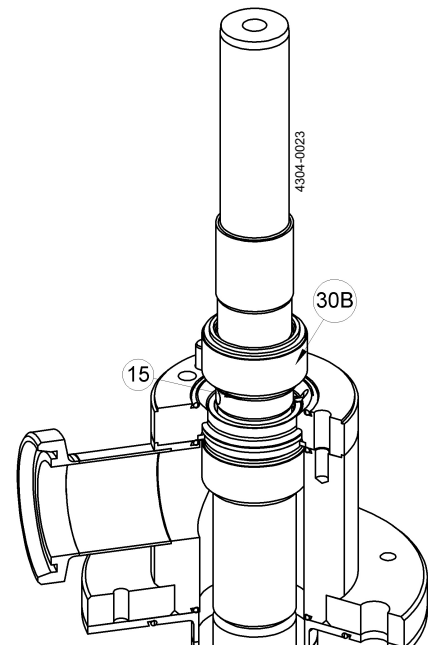

Step 8

5.2.8

1. Remove the pins (12).
2. The part (8) is removed as one part together with: O-ring (36) and the stationary part of the mechanical seal (30A) (including O-ring).
3. The Gasket support (31) is removed (only for type with Aeration – item number 9614322301).

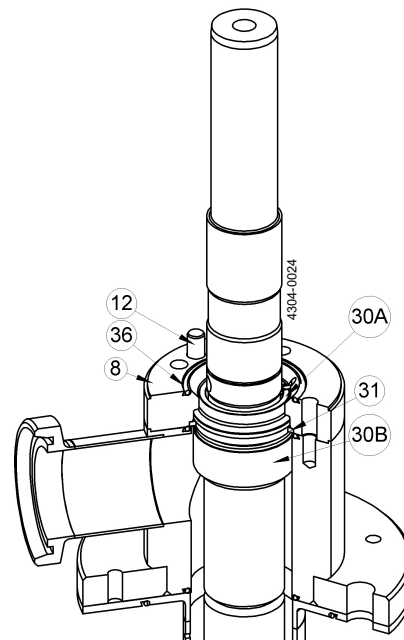

All position numbers and item numbers refer to the drawings shown and specified in chapter 7 Parts list/Service kits.

Step 9

5.2.9

1. Remove the Console (9) together with the O-rings (36).
2. Add some grease to the shaft and pull up the rotating part of the seal (30B).
3. Remove the CIP Tube (10).
4. Remove the Spray ball bearing (33).

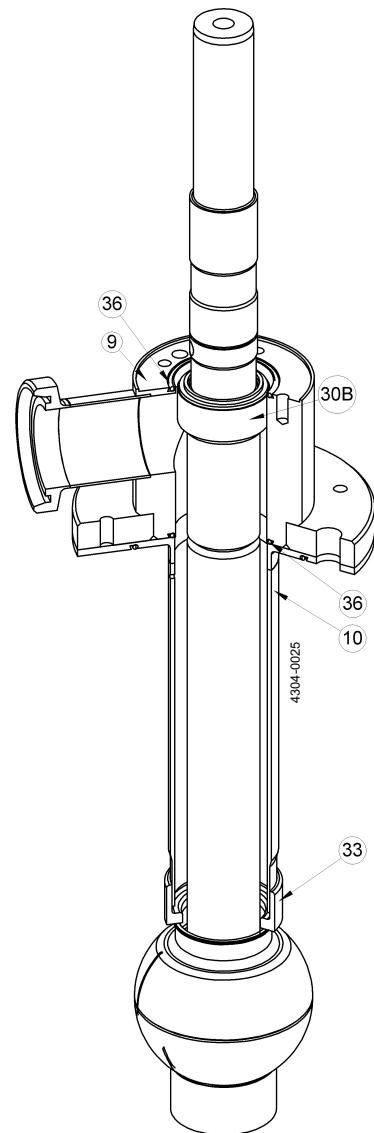

5 Maintenance

All position numbers and item numbers refer to the drawings shown and specified in chapter 7 Parts list/Service kits.

5.3 Assembling of Agitator

Read instructions below and follow section 5.2 Disassembling of Agitator in reverse order.

5.3.1 Mounting of O-rings in general

Step 1

Apply some food-approved grease to the O-ring.



Figure 7, Greasing O-ring

Step 2

Press the O-ring into the appropriated groove at position 0° and 180°.



Figure 8, Inserting O-ring

Step 3

Press the O-ring into the appropriated groove at position 90° and 270°.



Figure 9, Inserting O-ring

All position numbers and item numbers refer to the drawings shown and specified in chapter 7 Parts list/Service kits.

5.3.2 Mounting of mechanical seals

Step 1

1. Apply some food-approved grease to the O-ring mounted on the stationary part of the seal (30B).
2. Mount O-ring on rotating part of the seal (30B) without twisting it "inside out".
3. Clean both seal surfaces on the seal (30A and 30B) with some alcohol.



Figure 10, O-ring for seal part 30B

5.4 Replacement of gear motor

See section 5.2 Disassembling of Agitator.

5.5 Replacement of seals

See section 5.2 Disassembling of Agitator.

6 Technical Data

6.1 ALT-SB-15, With Aeration (item number 9614322301)

Environmental requirements:	
Temperature:	10°C - 40°C
Relative humidity:	20% - 80%
Size:	
See order confirmation/delivery note:	Dimensions to be found in chapter 7 Parts list/Service kits
Power supply:	
See gear motor and/or order confirmation/delivery note.	
CIP (through both connections position 27 and position 28):	
Temperature:	< 90°C, recommended about 65°C
Pressure:	1-3 bar above tank pressure depending on tank size
Quantity:	12-21 m ³ /h
Flow [m ³ /hour]:	12 x p ^{0,5} , at pressure p [barg]
Detergent:	Suitable for: steel EN 1.4404, PTFE and EPDM
Aeration (sterile air):	
Pressure:	1 barg (1 bar above tank pressure)
Quantity:	35-100 l/min depending on tank size (100 l/min = 6 m ³ /hour)
Flow [m ³ /hour]:	90 x p ^{0,5} , at pressure p [barg]
Material:	
See order confirmation/delivery note:	Data to be found in chapter 7 Parts list/Service kits

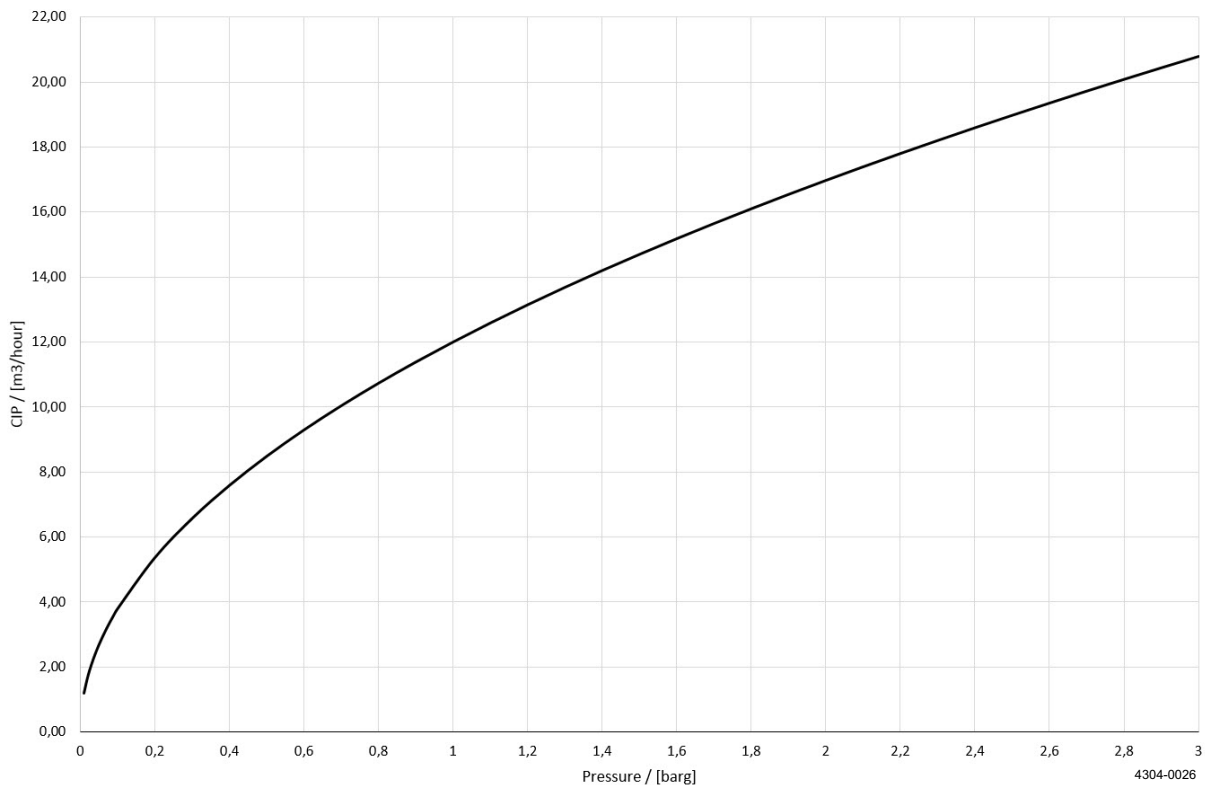

Figure 11, CIP flow versus pressure, type with aeration

4304-0026

6.2 ALT-SB-15, Without Aeration (item number 9614328901)

Environmental requirements:	
Temperature:	10°C - 40°C
Relative humidity:	20% - 80%
Size:	
See order confirmation/delivery note:	Dimensions to be found in chapter 7 Parts list/Service kits
Power supply:	
See gear motor and/or order confirmation/delivery note.	
CIP (through connections position 27):	
Temperature:	< 90°C, recommended about 65°C
Pressure:	1-3 bar above tank pressure depending on tank size
Quantity:	12-21 m ³ /h
Flow [m ³ /hour]:	12 x p ^{0,5} , at pressure p [barg]
Detergent:	Suitable for: steel EN 1.4404, PTFE and EPDM
Material:	
See order confirmation/delivery note:	Data to be found in chapter 7 Parts list/Service kits

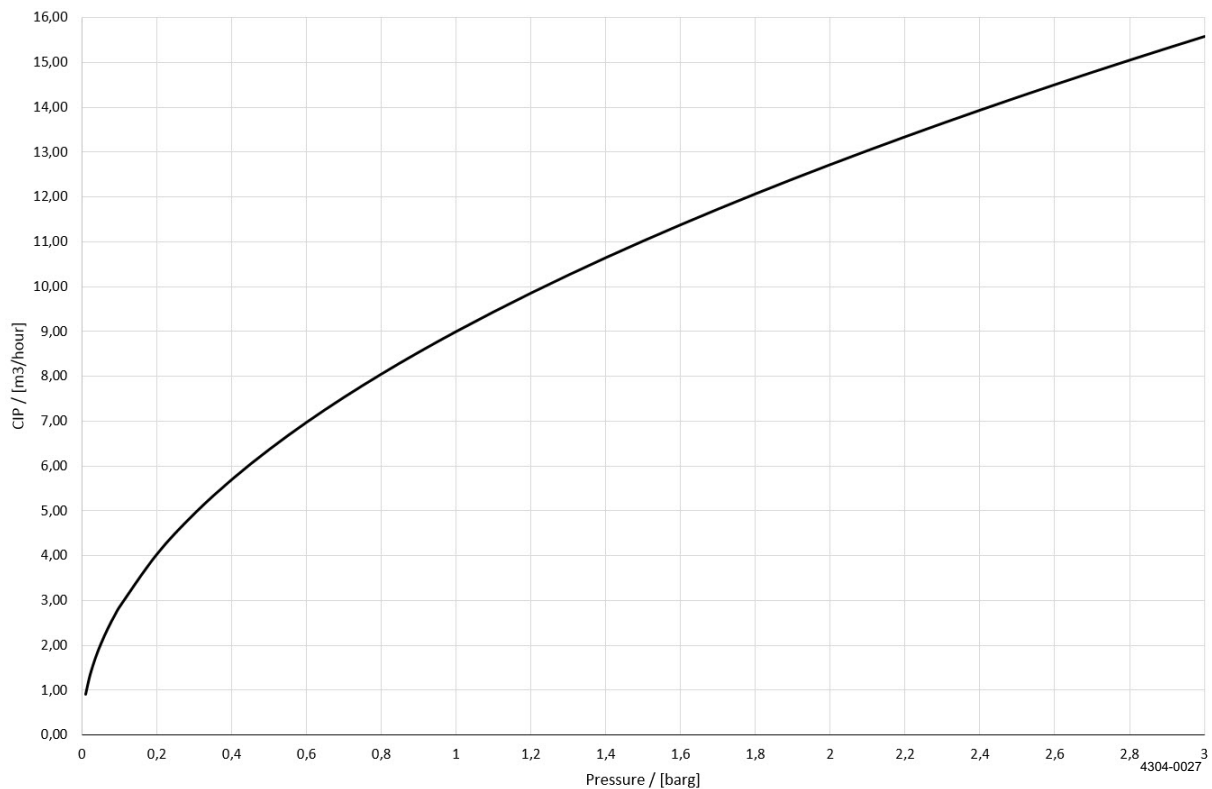

Figure 12, CIP flow versus pressure, type without aeration

7 Parts list/Service kits

All possible configurations described below. Always use original Alfa Laval parts.

7.1 ALT-SB-15, with aeration

7.1.1 Drawing (item number 9614322301)

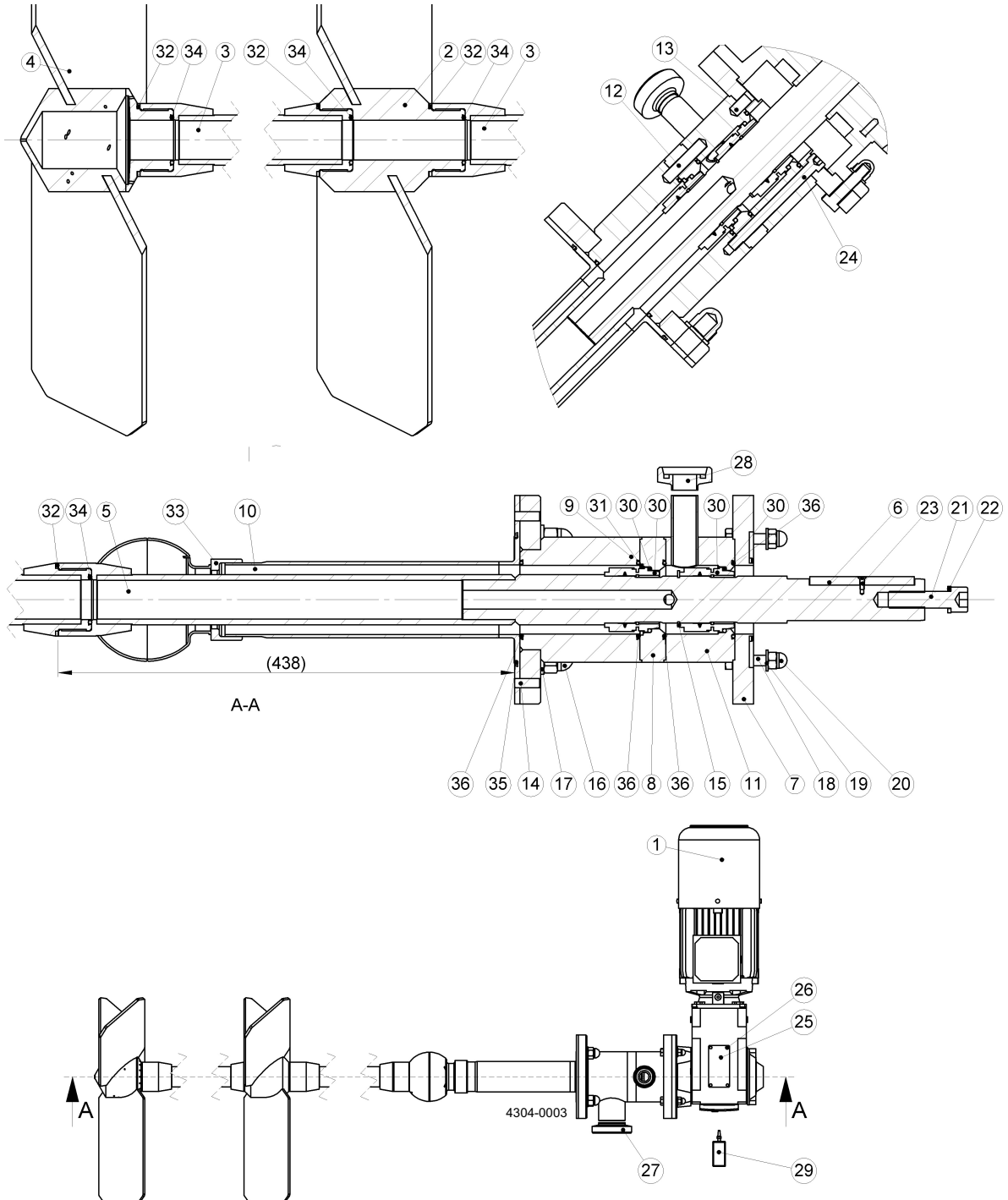

7 Parts list/Service kits

All possible configurations described below. Always use original Alfa Laval parts.

7.1.2 Part list (item number 9614322301):

Pos	Qty	Item #	Drawing #	Denomination	Material
1	1	See table*	96143250	Gear motor	NA
2	1	See table*	96143199	Propeller for agitator, Upper	14.404
3	2	See table*	96143204	Agitator shaft, Welded	14.404
4	1	See table*	96143275	Propeller, Lower	14.404
5	1	9614328601	96143286	Gear shaft	14.404
6	1	9614313403	96143134	Parallel key	1.4307/1.4301
7	1	9614318301	96143183	Flange, Upper for Agitator	1,4404
8	1	9614319701	96143197	Intermedia coupling welded	14.404
9	1	9614317901	96143179	Console for Agitator, Welded	14.404
10	1	9614318502	96143185	Tube, CIP for spray ball	14.404
11	1	9614319301	96143193	Gear console with aeration	14.404
12	2	9614313504	96143135	Pin	14.404
13	2	9614313503	96143135	Pin	14.404
14	2	9614313501	96143135	Pin	14.404
15	1	TE2601000199	None	Circlip, outer	A2
16	4	TE2601000058	None	Cap nut	A2
17	4	TE2601000348	None	Washer	A2
18	4	TE2601000630	None	Screw	A2
19	4	TE2601000346	None	Washer	A2
20	4	TE2601000355	None	Cap nut	A2
21	1	TE2601000047	None	Screw	A2
22	1	TE2601000169	None	Washer	A2
23	1	TE2601000644	None	Screw	A2
24	4	TE2601000631	None	Screw	A2
25	1	TE2601041560	4156	Name plate	AISI 304L
26	4	TE2601000202	None	Rivet	A2
27	1	3131800111	None	NW65	14.404
28	1	3131800071	None	NW25	14.404
29	1	9614314101	96143141	Loctite 2701, 10 ml	NA
30	2	9614321601	96143216	Single Mechanical seal	EN 12756: Y1/Q1/E/G/G
31	1	9614319201	96143192	Gasket support	1,4404
32	4	9614311803	96143118	Gasket	PTFE
33	1	9614329901	96143299	Spray ball bearing	PTFE
34	4	9614312702	96143127	O-ring	EPDM
35	1	9614312704	96143127	O-ring	EPDM
36	4	9614312703	96143127	O-ring	EPDM

* Not part of top level item number - item number must be selected on drawing

7.1.3 Spare Part Kit

Spare Part Kit item number 9614322302 includes parts pos. #29 to #36

7 Parts list/Service kits

All possible configurations described below. Always use original Alfa Laval parts.

7.2 ALT-SB-15, without aeration

7.2.1 Drawing (item number 9614328901)

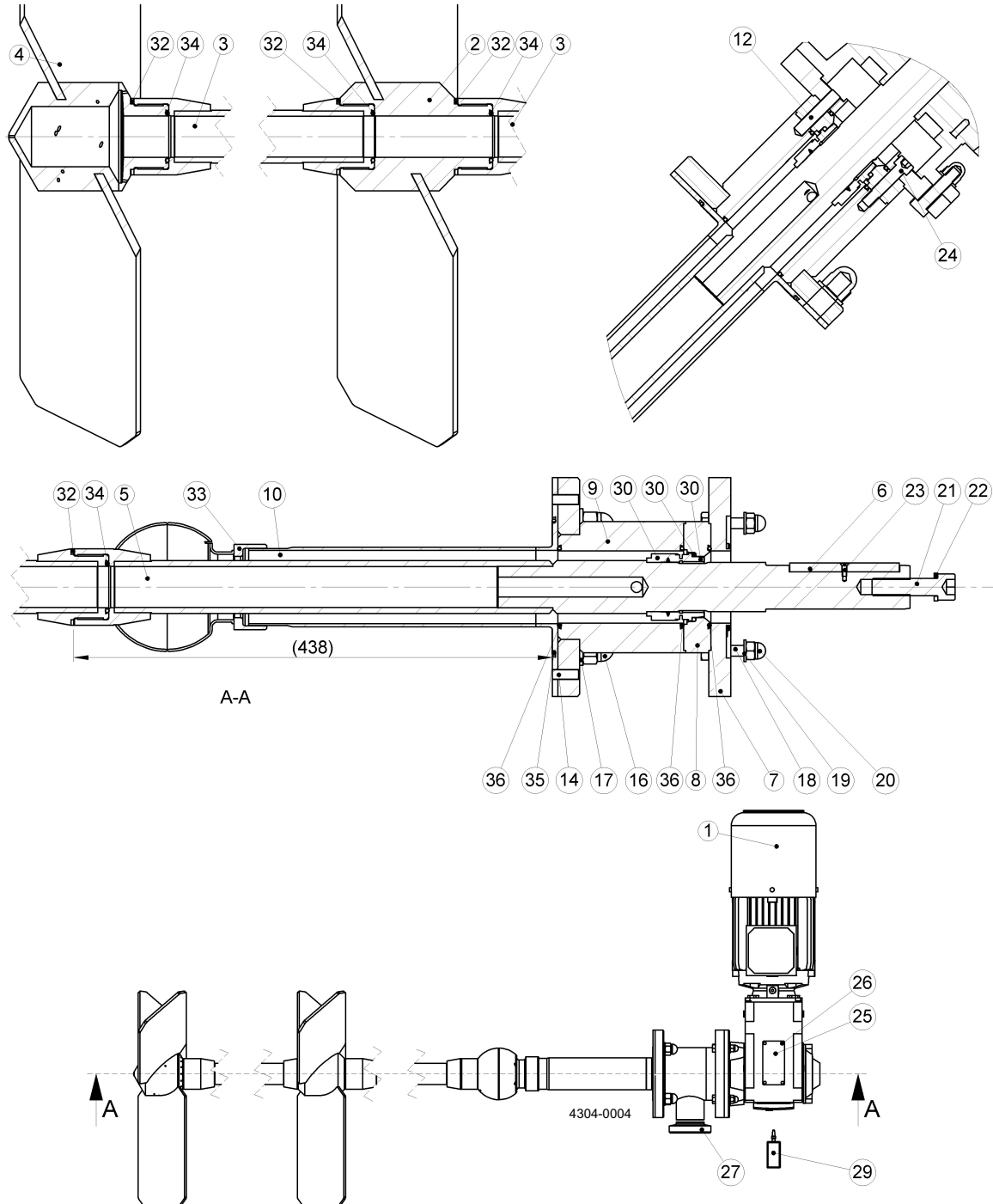

7 Parts list/Service kits

All possible configurations described below. Always use original Alfa Laval parts.

7.2.2 Part list (item number 9614328901)

Pos	Qty	Item #	Drawing #	Denomination	Material
1	1	See table*	96143250	Gear motor	NA
2	1	See table*	96143199	Propeller for agitator, Upper	14.404
3	2	See table*	96143204	Agitator shaft, Welded	14.404
4	1	See table*	96143275	Propeller, Lower	14.404
5	1	9614329001	96143290	Gear shaft	14.404
6	1	9614313403	96143134	Parallel key	1.4307/1.4301
7	1	9614318301	96143183	Flange, Upper for Agitator	1,4404
8	1	9614319701	96143197	Intermedia coupling welded	14.404
9	1	9614317901	96143179	Console for Agitator, Welded	14.404
10	1	9614318502	96143185	Tube, CIP for spray ball	14.404
11	0				
12	2	9614313504	96143135	Pin	14.404
13	0				
14	2	9614313501	96143135	Pin	14.404
15	0				
16	4	TE2601000058	None	Cap nut	A2
17	4	TE2601000348	None	Washer	A2
18	4	TE2601000630	None	Screw	A2
19	4	TE2601000346	None	Washer	A2
20	4	TE2601000355	None	Cap nut	A2
21	1	TE2601000047	None	Screw	A2
22	1	TE2601000169	None	Washer	A2
23	1	TE2601000644	None	Screw	A2
24	4	TE2601000632	None	Screw	A2
25	1	TE2601041560	4156	Name plate	AISI 304L
26	4	TE2601000202	None	Rivet	A2
27	1	3131800111	None	NW65	14.404
28	0				
29	1	9614314101	96143141	Loctite 2701, 10 ml	NA
30	1	9614321601	96143216	Single Mechanical seal	EN 12756:
31	0				
32	4	9614311803	96143118	Gasket	1,4404
33	1	9614329901	96143299	Spray ball bearing	PTFE
34	4	9614312702	96143127	O-ring	PTFE
35	1	9614312704	96143127	O-ring	EPDM
36	3	9614312703	96143127	O-ring	EPDM

* Not part of top level item number - item number must be selected on drawing

7.1.3 Spare Part Kit

Spare Part Kit item number 9614328902 includes parts pos. #29 to #36

7 Parts list/Service kits

7.3 ALT-SB-15, with and without aeration

7.3.1 Gear motor, Variants (Drawing number 96143250)

Gear motor specification	
Type:	High efficient Helical Bevel
Shaft material:	1,4057
Motor temperature protection:	PTC resistor, 3x155°C
Motor backstop / Freewheel bearing:	Yes
Lubrication type*:	Food-compatible oil ISI VG 220
Lubrication supplier*:	Klüber
Lubrication classification*:	CLP PG H1 220
Lubrication quantity:	1,2 ltr
Surface colour:	RAL 5010
Surface treatment:	Pain coat 3,0, 110-150 µm
Surface corrosion class:	EN 12944, C2
Labelling:	According to local legislation

**For more information and certificate see section 8.4 Drive Unit instructions*

Please contact Alfa Laval if a new gear motor is required. In this way it is ensured that the new gear motor fulfils all local legislation.

7.3.2 Propeller, Upper, Drawing (Drawing number 96143199)

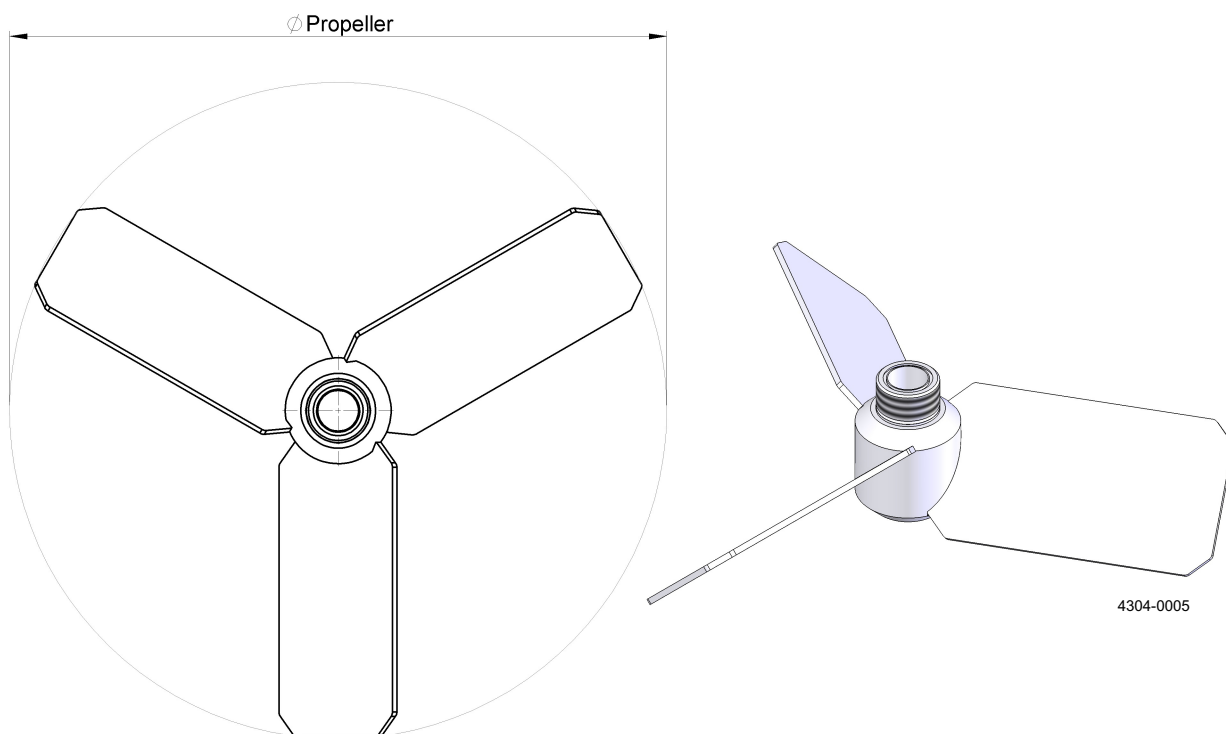

7.3.3 Propeller, Upper, Variants (Drawing number 96143199)

Item #	Drawing #	∅Propeller / [mm]
9614319901	96143199	614
9614319902	96143199	664
9614319903	96143199	713
9614319904	96143199	763
9614319905	96143199	813
9614319906	96143199	863
9614319907	96143199	912
9614319908	96143199	962
9614319909	96143199	1012
9614319910	96143199	1062
9614319911	96143199	1112
9614319912	96143199	564
9614319913	96143199	515
9614319914	96143199	466
9614319915	96143199	416
9614319916	96143199	367

7 Parts list/Service kits

7.3.4 Agitator shaft, welded, Drawing (Drawing number 96143204)

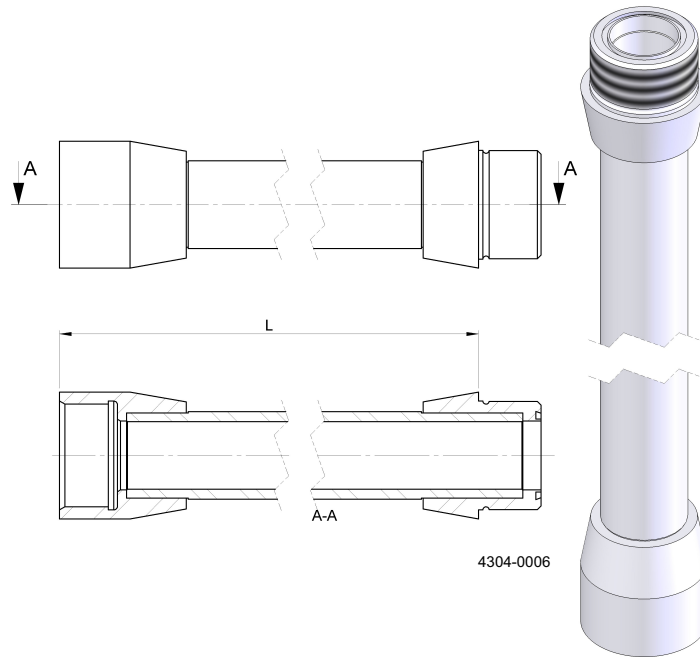

7.3.5 Agitator shaft, welded, Variants (Drawing number 96143204)

Item #	Drawing #	L / [mm]
9614320401	96143204	800
9614320402	96143204	900
9614320403	96143204	1000
9614320404	96143204	1100
9614320405	96143204	1200
9614320406	96143204	1300
9614320407	96143204	1400
9614320408	96143204	1500
9614320409	96143204	1600
9614320410	96143204	1700
9614320411	96143204	1800
9614320412	96143204	1900
9614320413	96143204	2000
9614320414	96143204	2100
9614320415	96143204	2200
9614320416	96143204	2300
9614320417	96143204	2400
9614320418	96143204	2500
9614320419	96143204	2600
9614320420	96143204	500
9614320421	96143204	550
9614320422	96143204	600
9614320423	96143204	650
9614320424	96143204	700
9614320425	96143204	750
9614320426	96143204	850
9614320427	96143204	950
9614320428	96143204	2700
9614320429	96143204	2800
9614320430	96143204	2900
9614320431	96143204	3000

7.3.6 Propeller, Lower, Drawing (Drawing number 96143275)

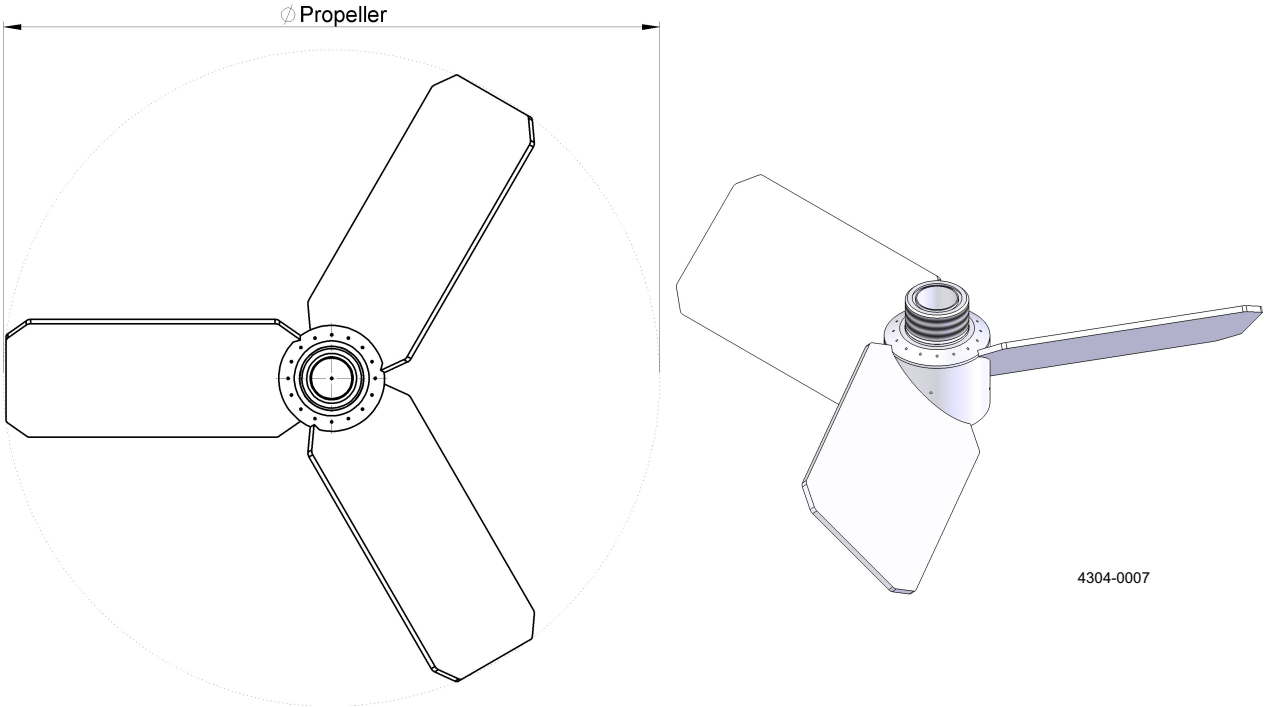

7.3.7 Propeller, Lower, Variants (Drawing number 96143275)

Item #	Drawing #	ØPropeller / [mm]
9614327501	96143275	613
9614327502	96143275	663
9614327503	96143275	712
9614327504	96143275	762
9614327505	96143275	812
9614327506	96143275	862
9614327507	96143275	912
9614327508	96143275	962
9614327509	96143275	1011
9614327510	96143275	1061
9614327511	96143275	1111
9614327512	96143275	563
9614327513	96143275	514
9614327514	96143275	464
9614327515	96143275	415
9614327516	96143275	366

7 Parts list/Service kits

7.4 Accessories

7.4.1 Mounting tool, Drawing (Drawing number 9614324701)

The mounting tool must be used for correct installation of SB Agitator Type 15

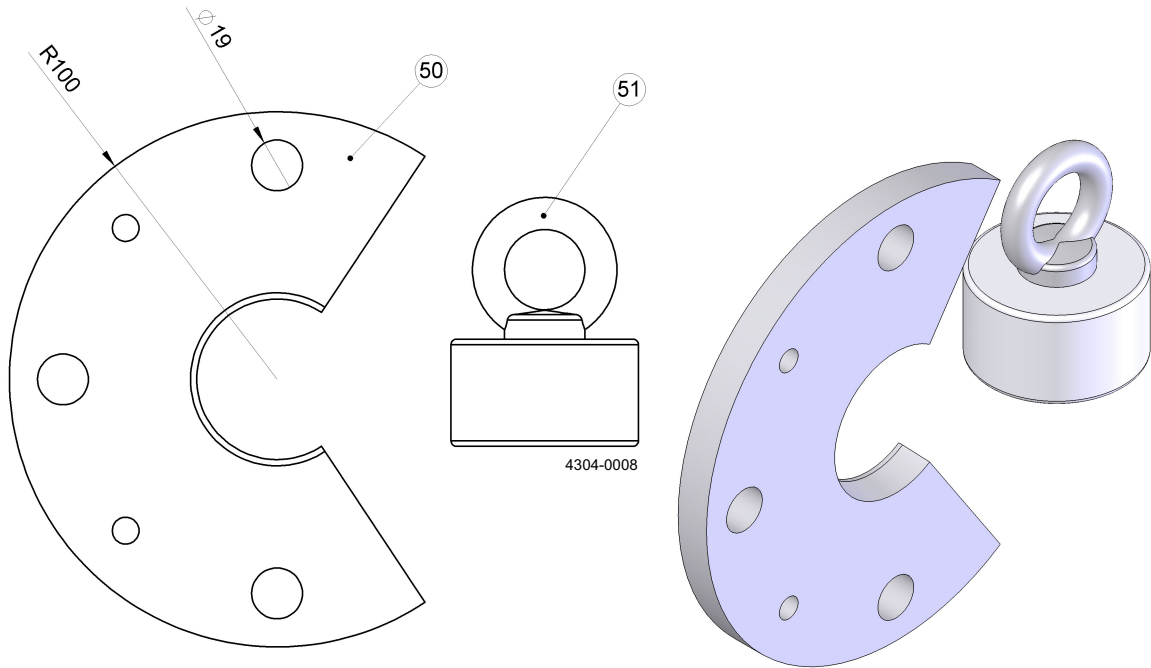

Mounting Tool, Parts list (Item number 9614324701)

Pos	Qty	Item #	Drawing #	Denomination	Material
50	1	9,61E+09	96143245	Tool – Fastener plate	Aluminium 6061 Alloy
51	1	9,61E+09	96143244	Tool – Lifting eye	1.4404 / A2

7.4.3 Welding Flange (Counter Flange), Drawing (Drawing number 9614323701)

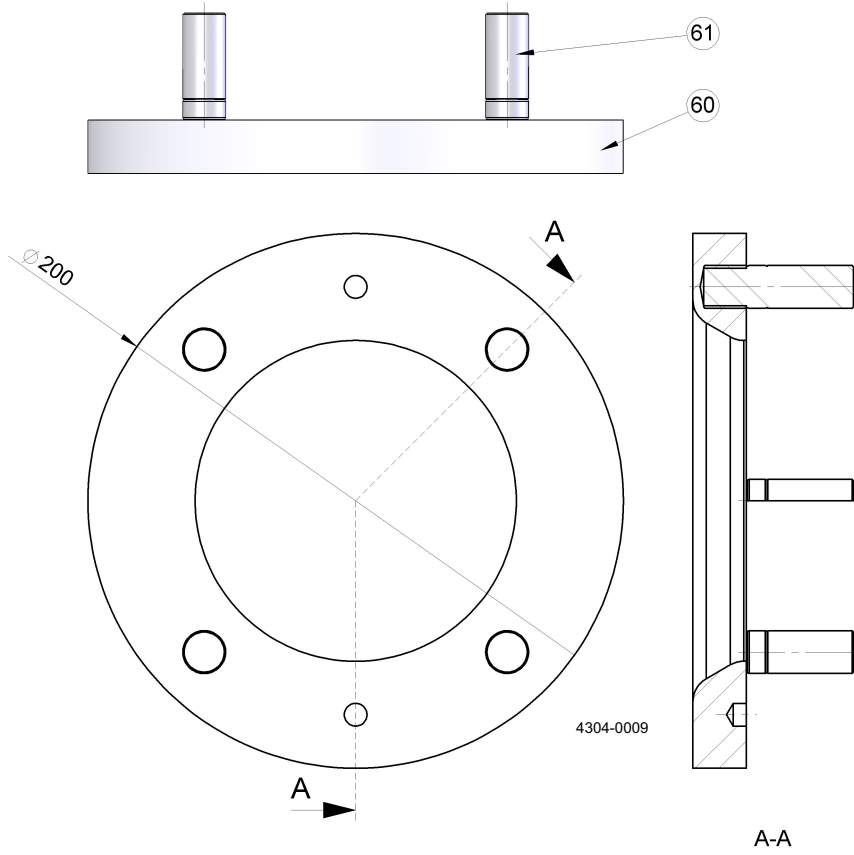

Welding Flange (Counter Flange), Parts List (Item number 9614323701)

Pos	Qty	Item #	Drawing #	Denomination	Material
60	1	9,61E+09	96143236	Welding Flange	14.404
61	4	TE2601000672	None	Stud	A2

7 Parts list/Service kits

All position numbers are according to drawings and part lists in chapter 7 Parts list/Service kits

7.5 Installation drawing

7.5.1 Complete Agitator in tank

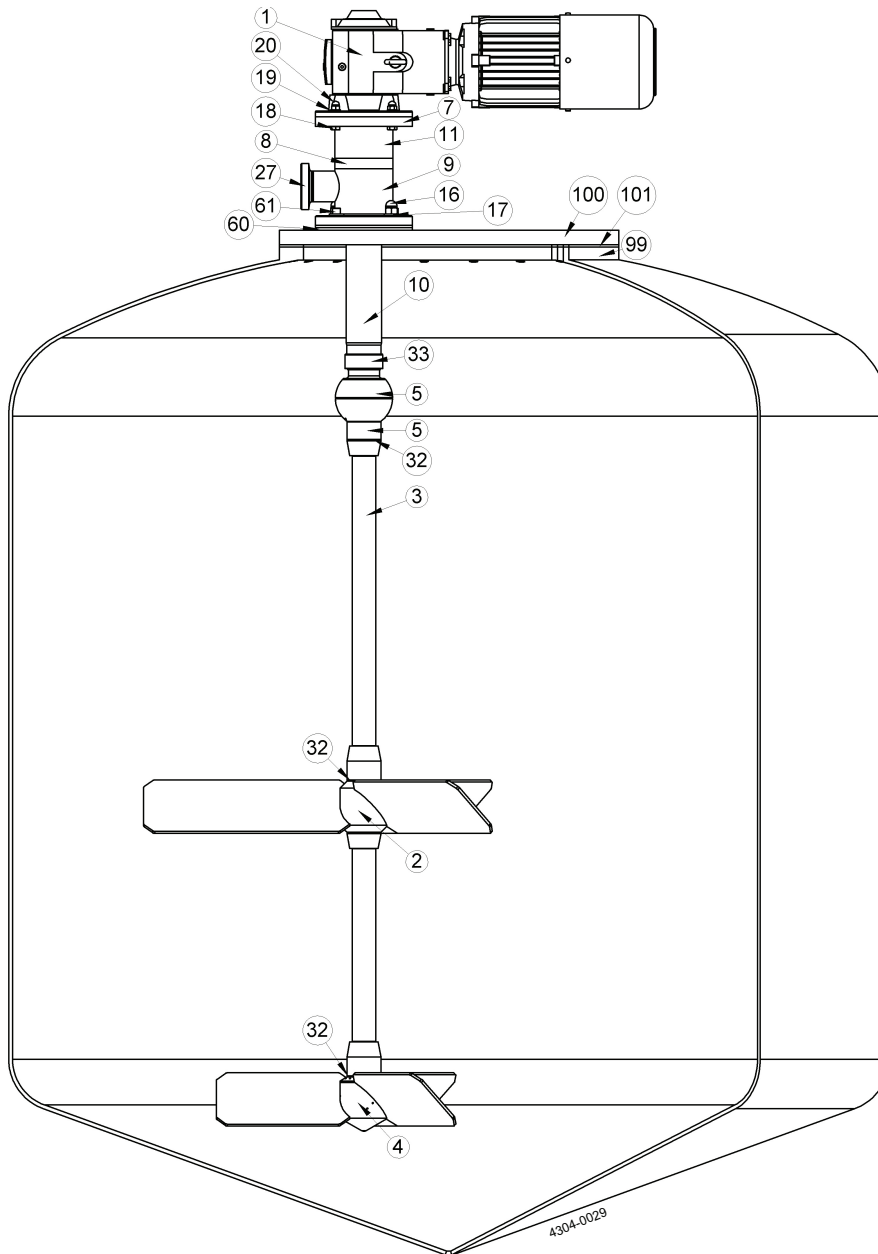

7.5.1 Complete Agitator in tank, Parts List

Pos	Qty	Item #	Drawing #	Denomination
99	1	NA	NA	Tank mounting flange (welding flange)
100	1	NA	NA	Top Plate
101	1	NA	NA	Top Plate gasket

All position numbers are according to drawings and part lists in chapter 7 Parts list/Service kits

8.1 Declaration of Compliance

Supplier

Alfa Laval Flow Equipment (Kunshan) Co Ltd
Baishu Road, Kunshan
Economic & Technical development Zone
Jiangsu - 215301 - P. R. China
Tel Switchboard: +86 512 577 145 04

Traceability

We as supplier hereby guarantee and certify that the materials and/or parts of equipment(s) stated in this manual have been manufactured in accordance to and comply with the Regulation (EC) No. 1935/2004 of the European Parliament and of the Council of 27 October 2004 on "Materials and articles intended to come into contact with food" regarding traceability.

Compliance for the U.S. Food & Drug Administration CFR 21 §177

We hereby confirm that the materials used in the equipment stated in this manual are suitable and licensed for FDA and can be used in food applications in accordance with FDA. Handling/assembly at Alfa Laval has not changed the material characteristics and parts have not been contaminated with unacceptable products. FDA Declarations from our suppliers can be forwarded upon request.

This Certified Mill Test Report is computer generated and is valid without signature

Michael Zhen, Quality Manager, Alfa Laval

8 Appendix

All position numbers are according to drawings and part lists in chapter 7 Parts list/Service kits

8.2 Order specific "Tank With Agitator" drawing, example

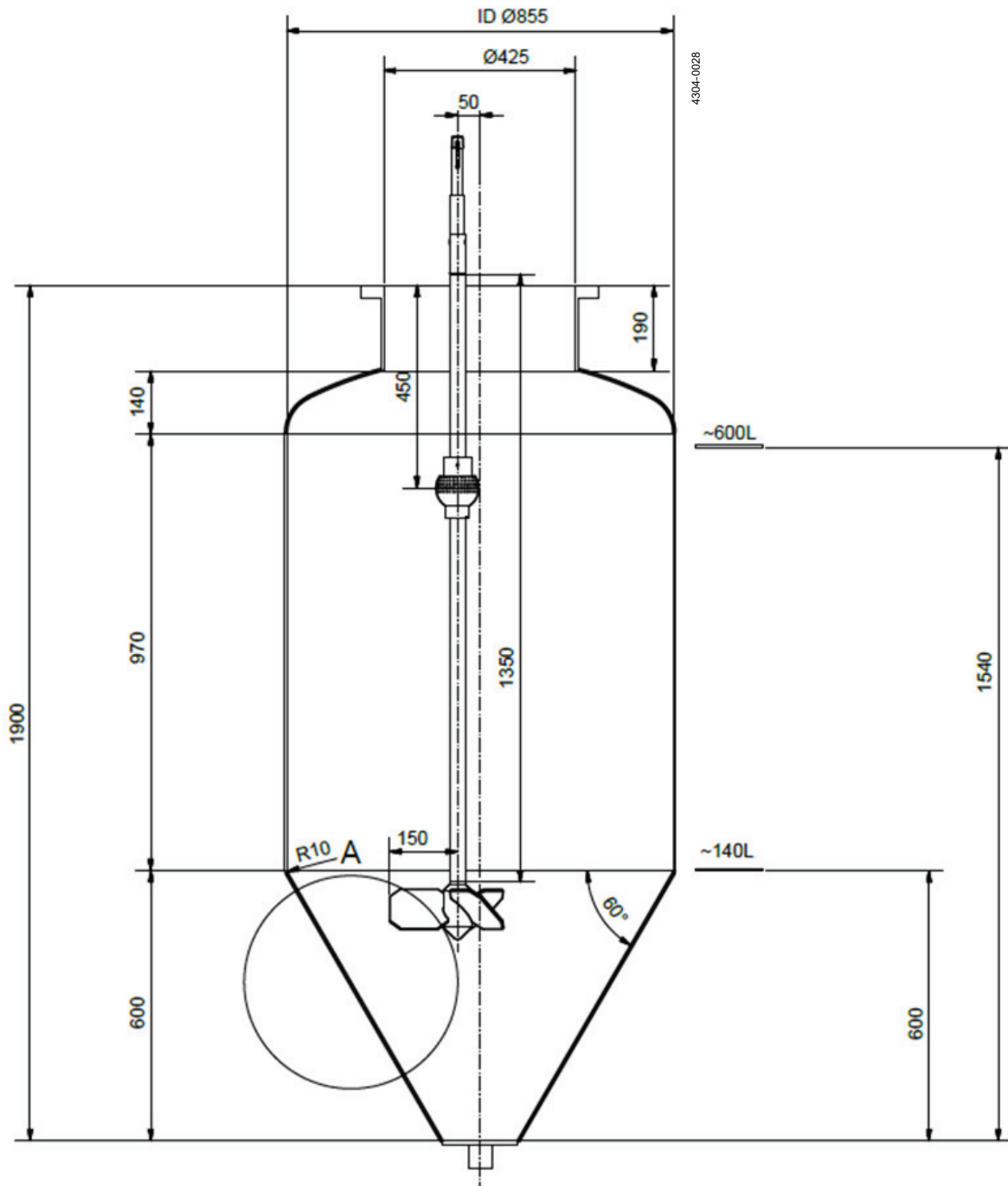

All position numbers are according to drawings and part lists in chapter 7 Parts list/Service kits

8.3 Drive Unit Lubrication



Product information

KLübersynth UH1 6 oils

Synthetic gear and high-temperature oils for the food-processing and pharmaceutical industries

Benefits for your application

- The oils meet the requirements according to DIN 51 517 – 03, CLP
- Registered by NSF as H1 lubricants for use in food-processing and pharmaceutical industries, complies with FDA 21 CFR Sec. 178.3570
- ISO 21469 certified – supports the compliance with the hygienic requirements in your production. You will find further information about ISO Standard 21469 on our website www.klueber.com.
- Much longer service life than mineral oils due to the excellent ageing and oxidation resistance of the base oil; thus maintenance intervals can be extended and in certain cases even lifetime lubrication is possible
- Owing to the wide service temperature range it is possible in many cases to use just one viscosity grade for both low and high temperatures
- The optimum friction behavior of the polyglycol base oil reduces power losses and improves efficiency
- The good wear protection of both gears and rolling bearings ensure that the service life calculated for the lubricated components is achieved.
- The oils' high micropitting resistance offers sufficient protection to gears that are subject to high loads and would normally be susceptible to this type of damage.
- The excellent viscosity-temperature behavior supports the formation of a sufficient lubricating film even at elevated and high temperatures.
- Seals made of 72 NBR 902, 75 FKM 585 and 75 FKM 170055 are resistant against KLübersynth UH1 6 oils.
- Approved by Flender, Siemens Geared Motors, SEW Eurodrive, Getriebebau Nord, Stöber Antriebstechnik, Lenze, ZAE Antriebstechnik Baldor, Boston Gear, Bonfiglioli, Watt Drive etc.

Description

KLübersynth UH1 6 oils are gear oils on a polyglycol basis. They have a high scuffing load capacity and micro-pitting resistance. These oils have also proved their good wear protection in rolling bearings on the FAG FE 8 test rig for gear oils.

KLübersynth UH1 6 oils stand out for their excellent ageing and oxidation resistance, good viscosity-temperature behaviour and very good thermal stability.

Application

KLübersynth UH1 6 oils are used for the lubrication of bevel and spur gears, rolling and plain bearings as well as all types of denture clutches, especially when exposed to high temperatures.

KLübersynth UH1 6 oils were especially developed for the lubrication of worm gears with steel/bronze pairings.

The polyglycol base oils and special additives reduce the friction coefficient and provide low wear values, which is a clear advantage in these applications.

KLübersynth UH1 6-100, 150, 220, 320, 460, 680, en
article number: 096094, 096056, 096059, 096063, 096060, 096064

Edition 12.09, replaces edition 07.09
MA-TM/HSI





Product information



KLübersynth UH1 6 oils

Synthetic gear and high-temperature oils for the food-processing and pharmaceutical industries

KLübersynth UH1 6 oils achieve a particularly low wear intensity according to DIN 3996 (calculation of load capacity). KLübersynth UH1 6 oils can also be used for the lubrication of lifting, drive and transport chains.

Application notes

KLübersynth UH1 6 oils can be applied by immersion, immersion/circulation and injection.

KLübersynth UH1 6 oils are **not** miscible with mineral oils and synthetic hydrocarbons like polyalphaolefins.

Application notes

We recommend cleaning the lubrication points or rinsing gears with the KLübersynth UH1 6 oil which will be used after conversion.

KLübersynth UH1 6 oils are neutral towards ferrous metals and almost all nonferrous metals.

There may be increased wear when the contact surfaces of design elements made of aluminium or aluminium alloys are exposed to dynamic loads. If necessary, preliminary tests should be carried out.

For permanent temperatures up to 80°C seals made of 72 NBR 902 may be used. For higher temperatures, we recommend to use seals made of 75 FKM 585.

It should be noted that elastomers from one or several manufacturers can behave differently.

When applying KLübersynth UH1 6 oils we recommend the use of two-component paints (reaction paints) for interior coating. Oil gauge glasses should preferably be made of natural glass or polyamide materials. Other transparent plastics, e.g. Plexiglas, have a tendency to crack under stress.

The suitability of materials used in contact with KLübersynth UH1 6 oils should be tested, especially prior to series application.

Viscosity selection

When determining the oil viscosity for gears, the manufacturer's instructions take priority. Only in cases where there are no gear manufacturer's instructions, the viscosity can be selected in accordance with the enclosed worksheet "KLübersynth UH1 6 oils – selection of oil viscosity for gears".

To determine the correct oil viscosity for bearings, please observe the bearing manufacturer's instructions.

For determining the existing viscosity, please refer to the enclosed viscosity-temperature diagram indicating the differing viscosity-temperature behavior of KLübersynth UH1 6 oils as compared to mineral oils.

Minimum shelf life

The minimum shelf life is approx. 36 months if the product is stored in its unopened original container in a dry, frost-free place.

Pack sizes

20 l canister
200 l drum

Material Safety Data Sheets

Material safety data sheets can be downloaded or requested via our website www.klueber.com. You may also obtain them through your contact person at Klüber Lubrication.

All position numbers are according to drawings and part lists in chapter 7 Parts list/Service kits



Product information

Klübersynth UH1 6 oils

Synthetic gear and high-temperature oils for the food-processing and pharmaceutical industries

Product data

Klübersynth UH1 6- ...	100	150	220	320	460	680
Marking acc. to DIN 51502	CLP PG 100	CLP PG 150	CLP PG 220	CLP PG 320	CLP PG 460	CLP PG 680
Marking acc. to ISO 12925-1	CKC 100	CKC 150	CKC 220	CKC 320	CKC 460	CKC 680
NSF-H1 registration*, registration no.	137872	124437	124438	124439	124440	124441
ISO VG DIN 51 519	100	150	220	320	460	680
Density, DIN 51 757, at 15 °C, [kg/m³], approx.	1040	1050	1060	1065	1075	1075
Kinematic viscosity, DIN 51 562, pt. 01 at 20 °C, [mm²/s], approx.	250	390	610	840	1270	1900
at 40 °C, [mm²/s], approx.	100	150	220	320	460	680
at 100 °C, [mm²/s], approx.	19.5	28.5	41	56	78	115
Viscosity index, DIN ISO 2909, approx.	≥ 190	≥ 210	≥ 220	≥ 220	≥ 240	≥ 250
Flash point, DIN ISO 2592, [°C]	≥ 220	≥ 220	≥ 220	≥ 220	≥ 220	≥ 220
Pour point, DIN ISO 3016, [°C]	≤ -45	≤ -35	≤ -35	≤ -30	≤ -30	≤ -25
Foaming characteristics, ASTM D 892, sequence I, II, III [ml]	≤ 100/10					
Copper corrosion, DIN EN 2160, 24 h, corrosion rating	1 - 100					
Corrosion protection on steel, DIN ISO 7120	0 - A					
Ageing characteristics, ASTM D 2893, increase in viscosity, [%]	≤ 6					
FZG gear test rig, A/8.3/90 DIN 14635-1, scuffing load stage	≥ 12					
FZG gear test rig, A/16.9/90 DIN 14635-1, scuffing load stage	≥ 11	≥ 12				
Rolling bearing test rig FE 8, D 7,5/80-80, DIN 51 819-3, wear of rolling elements, [mg]	≤ 30					
Lower service temperature range**, [°C]	-35				-30	-25
Upper service temperature range**, [°C]	160					

* This lubricant is registered as H1, which means that it has been designed for incidental, technically unavoidable food contact. Experience shows that it can be used for equivalent applications in the cosmetic and pharmaceutical industry under the conditions described in the product information leaflet. Specific test results as e.g. biocompatibility, which could be an additional requirement for applications in the pharmaceutical industry, are not available for this product. Therefore, before using the lubricant adequate risk analyses should be performed and, if necessary, suitable measures be taken by the manufacturer and user of installations in order to exclude the risk of health hazards and personal injuries.

** Service temperatures are guide values which depend on the lubricant's composition, the intended use and the application method. Lubricants change their consistency, shear viscosity or viscosity depending on the mechano-dynamical loads, time, pressure and temperature. These changes in product characteristics may affect the function of a component.

Klübersynth UH1 6-100, 150, 220, 320, 460, 680, en
article number: 096094, 096058, 096059, 096063, 096060, 096064

Edition 12.09, replaces edition 07.09
MA-TM/HSI

8 Appendix

All position numbers are according to drawings and part lists in chapter 7 Parts list/Service kits



Product information

Klübersynth UH1 6 oils

Synthetic gear and high-temperature oils for the food-processing and pharmaceutical industries

Viscosity-Temperature Diagram

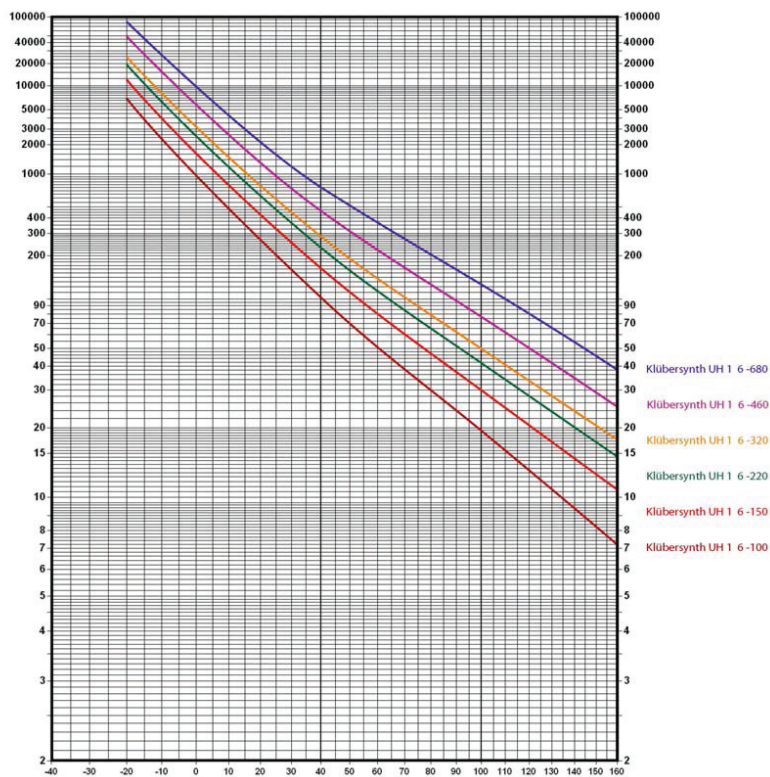

Lubrication is our world

With more than 2000 products available around the world, you can be sure that Klüber has the right product for your application. Please contact Klüber Lubrication specialists worldwide to assist you in all matters regarding lubrication.

www.klueber.com

Klüber Lubrication München KG, Geisenhausenerstraße 7, 81379 München, Germany, phone +49 89 7876-0, fax +49 89 7876-333.

The data in this product information is based on our general experience and knowledge at the time of printing and is intended to give information of possible applications to a reader with technical experience. It constitutes neither an assurance of product properties nor does it release the user from the obligation of performing preliminary tests with the selected product. We recommend contacting our Technical Consulting Staff to discuss your specific application. If required and possible we will be pleased to provide a sample for testing. Klüber products are continually improved. Therefore, Klüber Lubrication reserves the right to change all the technical data in this product information at any time without notice.



Klüber Lubrication, a company of the Freudenberg Group

Publisher and Copyright: Klüber Lubrication München KG. Reprints, total or in part, are permitted if source is indicated and voucher copy is forwarded.



All position numbers are according to drawings and part lists in chapter 7 Parts list/Service kits



NSF International / Nonfood Compounds Registration Program

Nonfood Compounds
Program Listed

July 28, 2008

Dr. Luciana Husfeld
KLUBER LUBRICATION MUNCHEN KG.
GEISENHAUSENER STR. 7
81379 MÜNCHEN
GERMANY

RE: Klübersynth UH1 6-220
Category Code: H1
NSF Registration No. 124438

Dear Dr. Luciana Husfeld:

NSF has processed the application for Registration of **Klübersynth UH1 6-220** to the NSF International Registration Guidelines for Proprietary Substances and Nonfood Compounds (2008), which are available at www.nsfwhitebook.org. The NSF Nonfood Compounds Registration Program is a continuation of the USDA product approval and listing program, which is based on meeting regulatory requirements including FDA 21 CFR for appropriate use, ingredient and labeling review.

This product is acceptable as a lubricant with incidental food contact (H1) for use in and around food processing areas. Such compounds may be used on food processing equipment as a protective anti-rust film, as a release agent on gaskets or seals of tank closures, and as a lubricant for machine parts and equipment in locations in which there is a potential exposure of the lubricated part to food. The amount used should be the minimum required to accomplish the desired technical effect on the equipment. If used as an anti-rust film, the compound must be removed from the equipment surface by washing or wiping, as required to leave the surface effectively free of any substance which could be transferred to food being processed.

NSF Registration of this product is current when the NSF Registration Number, Category Code, and Registration Mark appear on the NSF-approved product label, and the Registered product name is included in the current NSF White Book Listing of Nonfood Compounds at the NSF website (www.nsfwhitebook.org). The NSF Registration Mark can be downloaded by clicking the "Download Registration Mark" link on the NSF website (www.nsfwhitebook.org).

NSF Listing of all Registered Nonfood compounds by NSF International is not an endorsement of those compounds, or of any performance or efficacy claims made by the manufacturer.

Registration status may be verified at any time via the NSF website, at www.nsfwhitebook.org. Changes in formulation or label, without the prior written consent of NSF, will void Registration, and will supersede the on-line listing.

Sincerely,

A handwritten signature in black ink that reads "Jennifer De France".

Jennifer De France
NSF Nonfood Compounds Registration Program

Company No: N04391

8 Appendix

All position numbers are according to drawings and part lists in chapter 7 Parts list/Service kits

8.4 Drive Unit instructions

Intelligent Drivesystems, Worldwide Services



GB

B1000

Operating and Assembly Instructions for
Gear Units and Geared Motors

DRIVESYSTEMS

All position numbers are according to drawings and part lists in chapter 7 Parts list/Service kits



Contents



1. Notes	4
1.1 General information.....	4
1.2 Safety and information symbols.....	4
1.3 Correct use.....	4
1.4 Safety information.....	5
1.5 Other documents.....	6
1.6 Disposal.....	6
2. Description of gear units	7
2.1 Type designations and gear unit types.....	7
2.2 Name plate.....	8
3. Assembly instructions, storage, preparation, installation	9
3.1 Storing the gear unit.....	9
3.2 Long-term storage.....	9
3.3 Transporting the gear unit.....	10
3.4 Preparing for installation.....	10
3.5 Installing the gear unit.....	11
3.6 Fitting hubs on the gear shafts.....	12
3.7 Fitting push-on gear units.....	13
3.8 Fitting shrink discs.....	15
3.9 Fitting the covers.....	16
3.10 Fitting a standard motor.....	17
3.11 Retrospective paintwork.....	18
3.12 Fitting the cooling coil to the cooling system.....	19
4. Commissioning	20
4.1 Checking the oil level.....	20
4.2 Activating the automatic lubricant dispenser.....	20
4.3 Operation with lubricant cooling.....	21
4.4 Running-in time for the worm gear unit.....	21
4.5 Checklist.....	21
5. Service and maintenance	22
5.1 Service and maintenance intervals.....	22
5.2 Service and maintenance work.....	22
6. Appendix	26
6.1 Versions and maintenance.....	26
6.2 Torque values.....	38
6.3 Troubleshooting.....	38
6.4 Lubricants.....	39
6.5 Lubricant quantities.....	41



1. Notes



1. Notes

1.1 General information

Read the Operating Manual carefully prior to performing any work on or putting the gear unit into operation. Strict compliance with the instructions in this Operating Manual is essential. Getriebbau NORD accepts no liability for damage to persons, materials or assets as a result of the non-observance of this Operating Manual, operating errors or incorrect use. General wearing parts, e.g. radial seals are excluded from the warranty. If additional components are attached to or installed in the gear unit (e.g. motor, cooling system, pressure sensor etc.) or components (e.g. cooling system) are supplied with the order, the operating instructions for these components must be observed. If geared motors are used, compliance with the Motor Operating Manual is also necessary. If you do not understand the contents of this Operating Manual or additional operating instructions, please consult Getriebbau NORD!

1.2 Safety and information symbols

Please always observe the following safety and information symbols!

	Danger!
	Risk of fatalities and injury
	Attention!
	Machine may be damaged
	Note!
	Useful information

1.3 Correct use

These gear units generate a rotational movement and are intended for use in commercial systems. The gear unit must only be used according to the information in the technical documentation from Getriebbau NORD.

	Danger!
	Use in explosion hazard areas is prohibited.

Strict compliance with the technical data on the rating plate is essential. The documentation must be observed. Appropriate safety measures must be taken for applications where failure of a gear unit or geared motor may result in injury.

All position numbers are according to drawings and part lists in chapter 7 Parts list/Service kits



1. Notes



1.4 Safety information

All work including transportation, storage, installation, electrical connection, commissioning, servicing, maintenance and repair must be performed **only by qualified specialist personnel**. It is recommended that repairs to NORD Products are carried out by the NORD Service department.

	<p>Danger! Installation and maintenance work must only be performed when gear units are at a standstill and have cooled down. The drive must be isolated and secured to prevent accidental start-up. CAUTION! Depending on the operating conditions, the temperature of the gear unit may exceed 60°C. Danger of burns! Protection against accidental contact may need to be installed. Tighten the drive elements or secure the parallel key before switching on.</p>
--	--

	<p>Danger! Only use the eyebolts attached to the gear unit for transport. No additional loads may be attached. Transportation aids and lifting gear must have an adequate load-bearing capacity.</p> <p>If geared motors have an additional eyebolt attached to the motor, this must also be used. Avoid pulling the eyebolts at an angle. The thread of the eyebolt must be fully screwed in.</p> <p>Observe all safety information, including that provided in the individual sections of this Operating Manual. All national and other regulations on safety and accident prevention must also be observed.</p>
--	--

	<p>Danger! Serious physical and property damage may result from inappropriate installation, non-designated use, incorrect operation, non-compliance with safety information, unauthorised removal of housing components or safety covers and structural modifications to the gear unit.</p>
--	---

www.nord.com

B1000-GB-0713

-5-



1. Notes



1.5 Other documents

Further information may be obtained from the following documents:
 - Gear unit catalogues (G1000, G2000, G1011, G1012, G1034, G1035)
 - Operating and maintenance instructions for the electric motor
 - if applicable, operating instructions for attached or supplied options

1.6 Disposal

Observe the current local regulations. In particular, lubricants must be collected and disposed of correctly.

Gear unit components:	Material:
Toothed wheels, shafts, rolling bearings, parallel keys, locking rings, ...	Steel
Gear unit housing, housing components, ...	Grey cast iron
Light alloy gear unit housing, light alloy gear unit housing components, ...	Aluminium
Worm gears, bushes, ...	Bronze
Radial seals, sealing caps, rubber components, ...	Elastomers with steel
Coupling components	Plastic with steel
Flat seals	Asbestos-free sealing material
Gear oil	Additive mineral oil
Synthetic gear oil (rating plate code: CLP PG)	Polyglycol-based lubricants
Cooling spiral, embedding material of the cooling spiral, screw fittings	Copper, epoxy, yellow brass

B1000-GB-0713

www.nord.com

-6-

All position numbers are according to drawings and part lists in chapter 7 Parts list/Service kits



2. Description of Gear Units



2.1 Type designations and gear unit types

Types	Descriptions	Options / Versions
SK 11E, SK 21E, SK 31E, SK 41E, SK 51E (single-stage) SK 02, SK 12, SK 22, SK 32, SK 42, SK 52, SK 62N SK 03, SK 13, SK 23, SK 33N, SK 43, SK 53 (3-stage) SK 62, SK 72, SK 82, SK 92, SK 102 (2-stage) SK 63, SK 73, SK 83, SK 93, SK 103 (3-stage)	Helical gear units	- Foot mounting with solid shaft A Hollow shaft version V Solid shaft version L Solid shaft both sides Z Drive flange B14 F Output flange B5 X Foot mounting XZ Base and output flange B14 XF Base and output flange B5 AL Reinforced axial drive bearings 5 Reinforced output shaft V Reinforced helical gear unit D Torque support K Torque console S Shrink disc VS Reinforced shrink disc EA Hollow shaft with internal spline G Rubber buffer VG Reinforced rubber buffer R Back stop B Fixing element H Covering cap as contact guard H66 Covering cap IP66 VL Reinforced bearings VL2 Agitator design VL3 Drywell agitator design IEC Standard motor mounting NEMA Standard motor mounting W With free drive shaft VI Viton radial seals OA Oil expansion vessel OT Oil level tank SC01 Synthetic oil ISO VG 220 CC Casing cover with cooling spiral DR Spring Loaded Breather H10 Modular contrate pre-stage /31 Worm pre-stage /40 Worm pre-stage
SK 320, SK 172, SK 372, SK 472, SK 572, SK 672, SK 772, SK 872, SK 972 (2-stage) SK 273, SK 373, SK 473, SK 573, SK 673, SK 773, SK 873, SK 973 (3-stage) SK 072.1, SK 172.1, SK 372.1, SK 472.1, SK 572.1, SK 772.1 SK 872.1, SK 972.1 (2-stage) SK 373.1, SK 473.1, SK 573.1, SK 673.1, SK 773.1, SK 873.1, SK 973.1 (3-stage)	NORBLOC helical gear units	
SK 0, SK 01, SK 20, SK 25, SK 30, SK 33 (2-stage) SK 010, SK 200, SK 250, SK 300, SK 330 (3-stage)	Standard helical gear units	
SK 0182NB, SK 0282NB, SK 1282, SK 2282, SK 3282, SK 4282, SK 5282, SK 6282, SK 7282, SK 8282, SK 9282, SK 10282, SK 11282 (2-stage) SK 1382NB, SK 2382, SK 3382, SK 4382, SK 5382, SK 6382, SK 7382, SK 8382, SK 9382, SK 10382, SK 11382, SK 12382 (3-stage)	Parallel shaft gear units	
SK 92072, SK 92172, SK 92272, SK 92372, SK 92472, SK 92572, SK 92672, SK 92772, SK 92872, SK 92972, SK 93072, SK 93172, SK 93272, SK 93372, SK 93472, SK 93572, SK 93672, SK 93772, SK 93872, SK 93972, SK 94072, SK 94172, SK 94272, SK 94372, SK 94472, SK 94572, SK 94672, SK 94772, SK 94872, SK 94972, SK 95072, SK 95172, SK 95272, SK 95372, SK 95472, SK 95572, SK 95672, SK 95772, SK 95872, SK 95972, SK 96072, SK 96172, SK 96272, SK 96372, SK 96472, SK 96572, SK 96672, SK 96772, SK 96872, SK 96972, SK 97072, SK 97172, SK 97272, SK 97372, SK 97472, SK 97572, SK 97672, SK 97772, SK 97872, SK 97972, SK 98072, SK 98172, SK 98272, SK 98372, SK 98472, SK 98572, SK 98672, SK 98772, SK 98872, SK 98972, SK 99072, SK 99172, SK 99272, SK 99372, SK 99472, SK 99572, SK 99672, SK 99772, SK 99872, SK 99972, SK 100072	Bevel gear units	
SK 9012.1, SK 9016.1, SK 9022.1, SK 9032.1, SK 9042.1, SK 9052.1, SK 9062.1, SK 9072.1, SK 9082.1, SK 9096.1, SK 9092.1, SK 9096.1 (5-stage) SK 9013.1, SK 9017.1, SK 9023.1, SK 9033.1, SK 9043.1, SK 9053.1 (4-stage)	Contrate worm gear unit	
SK 02040, SK 02050, SK 12063, SK 12080, SK 32100, SK 42125 (2-stage) SK 13050, SK 13063, SK 13080, SK 33100, SK 43125 (3-stage)	Contrate worm gear unit	
SK 1532, SK 1540, SK 1550, SK 1563, SK 1575, SK 1583, SK 1596, SK 1610, SK 1625, SK 1640, SK 1655, SK 1670, SK 2532NB, SK 2540NB, SK 2550NB, SK 2563NB, SK 2575, SK 2590, SK 2605, SK 2620, SK 2635, SK 2650, SK 2665, SK 2680, SK 2695, SK 2710, SK 2725, SK 2740, SK 2755, SK 2770, SK 2785, SK 2800, SK 2815, SK 2830, SK 2845, SK 2860, SK 2875, SK 2890, SK 2905, SK 2920, SK 2935, SK 2950, SK 2965, SK 2980, SK 2995, SK 3010, SK 3025, SK 3040, SK 3055, SK 3070, SK 3085, SK 3100, SK 3115, SK 3130, SK 3145, SK 3160, SK 3175, SK 3190, SK 3205, SK 3220, SK 3235, SK 3250, SK 3265, SK 3280, SK 3295, SK 3310, SK 3325, SK 3340, SK 3355, SK 3370, SK 3385, SK 3400, SK 3415, SK 3430, SK 3445, SK 3460, SK 3475, SK 3490, SK 3505, SK 3520, SK 3535, SK 3550, SK 3565, SK 3580, SK 3595, SK 3610, SK 3625, SK 3640, SK 3655, SK 3670, SK 3685, SK 3700, SK 3715, SK 3730, SK 3745, SK 3760, SK 3775, SK 3790, SK 3805, SK 3820, SK 3835, SK 3850, SK 3865, SK 3880, SK 3895, SK 3910, SK 3925, SK 3940, SK 3955, SK 3970, SK 3985, SK 4000, SK 4015, SK 4030, SK 4045, SK 4060, SK 4075, SK 4090, SK 4105, SK 4120, SK 4135, SK 4150, SK 4165, SK 4180, SK 4195, SK 4210, SK 4225, SK 4240, SK 4255, SK 4270, SK 4285, SK 4300, SK 4315, SK 4330, SK 4345, SK 4360, SK 4375, SK 4390, SK 4405, SK 4420, SK 4435, SK 4450, SK 4465, SK 4480, SK 4495, SK 4510, SK 4525, SK 4540, SK 4555, SK 4570, SK 4585, SK 4600, SK 4615, SK 4630, SK 4645, SK 4660, SK 4675, SK 4690, SK 4705, SK 4720, SK 4735, SK 4750, SK 4765, SK 4780, SK 4795, SK 4810, SK 4825, SK 4840, SK 4855, SK 4870, SK 4885, SK 4900, SK 4915, SK 4930, SK 4945, SK 4960, SK 4975, SK 4990, SK 5005, SK 5020, SK 5035, SK 5050, SK 5065, SK 5080, SK 5095, SK 5110, SK 5125, SK 5140, SK 5155, SK 5170, SK 5185, SK 5200, SK 5215, SK 5230, SK 5245, SK 5260, SK 5275, SK 5290, SK 5305, SK 5320, SK 5335, SK 5350, SK 5365, SK 5380, SK 5395, SK 5410, SK 5425, SK 5440, SK 5455, SK 5470, SK 5485, SK 5500, SK 5515, SK 5530, SK 5545, SK 5560, SK 5575, SK 5590, SK 5605, SK 5620, SK 5635, SK 5650, SK 5665, SK 5680, SK 5695, SK 5710, SK 5725, SK 5740, SK 5755, SK 5770, SK 5785, SK 5800, SK 5815, SK 5830, SK 5845, SK 5860, SK 5875, SK 5890, SK 5905, SK 5920, SK 5935, SK 5950, SK 5965, SK 5980, SK 5995, SK 6010, SK 6025, SK 6040, SK 6055, SK 6070, SK 6085, SK 6100, SK 6115, SK 6130, SK 6145, SK 6160, SK 6175, SK 6190, SK 6205, SK 6220, SK 6235, SK 6250, SK 6265, SK 6280, SK 6295, SK 6310, SK 6325, SK 6340, SK 6355, SK 6370, SK 6385, SK 6400, SK 6415, SK 6430, SK 6445, SK 6460, SK 6475, SK 6490, SK 6505, SK 6520, SK 6535, SK 6550, SK 6565, SK 6580, SK 6595, SK 6610, SK 6625, SK 6640, SK 6655, SK 6670, SK 6685, SK 6700, SK 6715, SK 6730, SK 6745, SK 6760, SK 6775, SK 6790, SK 6805, SK 6820, SK 6835, SK 6850, SK 6865, SK 6880, SK 6895, SK 6910, SK 6925, SK 6940, SK 6955, SK 6970, SK 6985, SK 7000, SK 7015, SK 7030, SK 7045, SK 7060, SK 7075, SK 7090, SK 7105, SK 7120, SK 7135, SK 7150, SK 7165, SK 7180, SK 7195, SK 7210, SK 7225, SK 7240, SK 7255, SK 7270, SK 7285, SK 7300, SK 7315, SK 7330, SK 7345, SK 7360, SK 7375, SK 7390, SK 7405, SK 7420, SK 7435, SK 7450, SK 7465, SK 7480, SK 7495, SK 7510, SK 7525, SK 7540, SK 7555, SK 7570, SK 7585, SK 7600, SK 7615, SK 7630, SK 7645, SK 7660, SK 7675, SK 7690, SK 7705, SK 7720, SK 7735, SK 7750, SK 7765, SK 7780, SK 7795, SK 7810, SK 7825, SK 7840, SK 7855, SK 7870, SK 7885, SK 7900, SK 7915, SK 7930, SK 7945, SK 7960, SK 7975, SK 7990, SK 8005, SK 8020, SK 8035, SK 8050, SK 8065, SK 8080, SK 8095, SK 8110, SK 8125, SK 8140, SK 8155, SK 8170, SK 8185, SK 8200, SK 8215, SK 8230, SK 8245, SK 8260, SK 8275, SK 8290, SK 8305, SK 8320, SK 8335, SK 8350, SK 8365, SK 8380, SK 8395, SK 8410, SK 8425, SK 8440, SK 8455, SK 8470, SK 8485, SK 8500, SK 8515, SK 8530, SK 8545, SK 8560, SK 8575, SK 8590, SK 8605, SK 8620, SK 8635, SK 8650, SK 8665, SK 8680, SK 8695, SK 8710, SK 8725, SK 8740, SK 8755, SK 8770, SK 8785, SK 8800, SK 8815, SK 8830, SK 8845, SK 8860, SK 8875, SK 8890, SK 8905, SK 8920, SK 8935, SK 8950, SK 8965, SK 8980, SK 8995, SK 9010, SK 9025, SK 9040, SK 9055, SK 9070, SK 9085, SK 9100, SK 9115, SK 9130, SK 9145, SK 9160, SK 9175, SK 9190, SK 9205, SK 9220, SK 9235, SK 9250, SK 9265, SK 9280, SK 9295, SK 9310, SK 9325, SK 9340, SK 9355, SK 9370, SK 9385, SK 9400, SK 9415, SK 9430, SK 9445, SK 9460, SK 9475, SK 9490, SK 9505, SK 9520, SK 9535, SK 9550, SK 9565, SK 9580, SK 9595, SK 9610, SK 9625, SK 9640, SK 9655, SK 9670, SK 9685, SK 9700, SK 9715, SK 9730, SK 9745, SK 9760, SK 9775, SK 9790, SK 9805, SK 9820, SK 9835, SK 9850, SK 9865, SK 9880, SK 9895, SK 9910, SK 9925, SK 9940, SK 9955, SK 9970, SK 9985, SK 10000	MINIBLOC worm gear units UNIVERSAL worm gear units	



2.2 Description of Gear Units

Double gear units consist of two single gear units. They are to be treated as per the instructions in this Manual, i.e. as two individual gear units. Type designation of double gear units: e.g. SK 73/22 (consisting of single gears SK 73 and SK 22)

2.2 Name plate

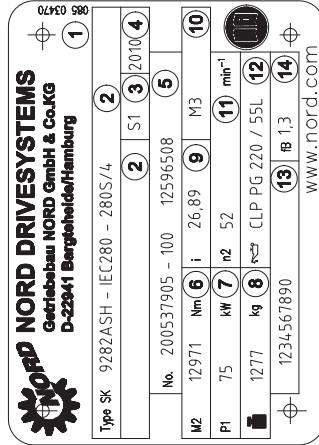

Figure 2-1: Name plate (example)

Explanation of the Name Plate

- 1 Matrix – Barcode
- 2 NORD gear unit type
- 3 Operating mode
- 4 Year of manufacture
- 5 Serial number
- 6 Rated torque of gear unit output shaft
- 7 Drive power
- 8 Weight according to ordered version
- 9 Overall gear unit ratio
- 10 Installation orientation
- 11 Rated speed of gear unit output shaft
- 12 Lubricant type, viscosity and quantity
- 13 Customer's part number
- 14 Operating factor



All position numbers are according to drawings and part lists in chapter 7 Parts list/Service kits



3. Assembly instructions, storage, preparation, installation



3. Assembly instructions, storage, preparation, installation

Please observe all of the general safety information in Section 1.4, 1.3 and in the individual sections.

3.1 Storing the gear unit

For short-term storage before commissioning, please observe the following:

- Store in the fitting position (see Section 6.1) and secure gear units against falling
- Lightly grease bare metal housing surfaces and shafts
- Store in dry rooms
- Temperature must not fluctuate beyond the range of -5°C to $+50^{\circ}\text{C}$
- Relative humidity less than 60%
- No direct exposure to sunlight or UV light
- No aggressive, corrosive substances (contaminated air, ozone, gases, solvents, acids, alkalis, salts, radioactivity etc.) in the immediate vicinity
- No vibration or oscillation

3.2 Long-term storage



Note!

For storage or standstill periods in excess of 9 months, Getriebebau NORD recommends the long-term storage option. With the long-term storage option and the use of the measures listed below, storage for up to 2 years is possible. As the actual influences on the unit greatly depend on the local conditions, these times should only be regarded as guide values.

Conditions of the gear unit and storage area for long-term storage prior to commissioning:

- Store in the fitting position (see Section 6.1) and secure gear units against falling
- Transportation damage to the external paint must be repaired. Check that a suitable rust inhibitor is applied to the flange bearing surfaces. If necessary apply a suitable rust inhibitor to the surfaces.
- Gear units with the long-term storage option are completely filled with lubricant or have VCI corrosion protection agents added to the gear oil. (See label on gear unit)
- The sealing band in the vent plug must not be removed during storage. The gear unit must remain sealed tight.
- Store in a dry place.
- In tropical regions, the drive unit must be protected against damage by insects
- Temperature must not fluctuate beyond the range of -5°C to $+40^{\circ}\text{C}$
- Relative humidity less than 60%
- No direct exposure to sunlight or UV light
- No aggressive, corrosive substances (contaminated air, ozone, gases, solvents, acids, alkalis, salts, radioactivity etc.) in the immediate vicinity
- No vibration or oscillation

Measures during storage or standstill periods

- If the relative humidity is $<50\%$ the gear unit can be stored for up to 3 years.

Measures before commissioning

- If the storage or standstill period exceeds 2 years or the temperature during short-term storage greatly deviates from the standard range, the lubricant in the gear unit must be replaced before commissioning.
- If the gear unit is completely filled, the oil level must be reduced before commissioning.



3. Assembly instructions, storage, preparation, installation



3.3 Transporting the gear unit



Danger!

To prevent injury, the danger area must be generously cordoned off. Standing under the gear unit during transport is extremely dangerous.

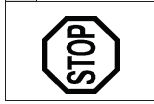

Attention!

Avoid damage to the gear unit. Impacts to the free ends of the shafts may cause internal damage to the gear unit.

Use adequately dimensioned and suitable means of transportation. Lifting tackle must be designed for the weight of the gear unit. The weight of the gear unit can be obtained from the dispatch documents.

3.4 Preparing for installation

The drive unit must be inspected and may only be installed if no transportation damage or leaks are visible. In particular the radial seals and the sealing caps must be inspected for damage.

All bare metal surfaces and shafts of the gear unit are protected against corrosion with oil, grease or corrosion protection agents before shipping.

Thoroughly remove all oil, grease or corrosion protection agents and any dirt from the shafts and flange surfaces before assembly.

In applications where an incorrect rotational direction may result in damage or potential risk, the correct rotational direction of the drive shaft is to be established by test running the drive when uncoupled and guaranteeing such for subsequent operation.

Gears with integrated return stops are marked with arrows on the driven/driving sides. The arrows point in the rotation direction of the gear unit. It must be ensured, when connecting the motor and during motor control, that the gear unit can only operate in the rotation direction, e.g. by means of a rotary field test. (For further details, please refer to Catalogue G1000 and WN 0-000 40)



Attention!

With gear units with an integrated back stop, switching the drive motor to the blocked rotation direction, i.e. incorrect rotation direction, can lead to gear damage.

Ensure that no aggressive or corrosive substances are present in the area surrounding the installation site or are subsequently expected during operation, which attack metal, lubricants or elastomers. In case of doubt, please contact Getriebebau NORD and take the recommended action.

Oil expansion tanks (Option OA) must be fitted in accordance with works standard WN 0-530 04. For gear units with an \square 10x1 vent plug, works standard WN 0-52135 must be observed.

Oil expansion tanks (Option OT) must be fitted in accordance with works standard WN 0-521 30.

If venting of the gear unit is provided, the vent or the pressure vent must be activated before commissioning. To activate, remove the transport securing devices (sealing cord). Position of the vent plug: see Section 6.1.

All position numbers are according to drawings and part lists in chapter 7 Parts list/Service kits



3. Assembly instructions, storage, preparation, installation



	<p>Danger!</p> <p>To ensure that the gearbox does not get too warm and to avoid injury to persons, observe the following during installation:</p> <ul style="list-style-type: none"> The surfaces of gear units or geared motors may become hot during or shortly after operation. Attention: danger of burns! Protection against accidental contact may need to be installed. With geared motors, the cooling air of the motor fan must be able to flow unobstructed onto the gear unit.
--	---

3.6 Fitting hubs on the gear shafts

	<p>Attention!</p> <p>Do not subject the gear unit to harmful axial forces when fitting the hubs.</p>
--	---

Drive and driven elements, e.g. coupling and chain-wheel hubs must be mounted onto the drive and driven shaft of the gear unit using suitable pullers that will not apply damaging axial forces onto the gear unit. In particular, do not hit the hubs with a hammer. Use the end thread of the shafts for pulling. Fitting can be aided by coating the hub with lubricant or heating it up to approx. 100°C beforehand.

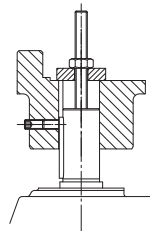

Figure 3-3: Example of a simple pulling device

	<p>Danger!</p> <p>Drive and driven elements, such as belt drives, chain drives and couplings must be fitted with contact protection.</p>
--	--

Driven elements may only subject the drive units to the maximum radial force F_R and axial force F_A as specified in the catalogue. Observe the correct tension, particularly on belts and chains. Additional loads due to unbalanced hubs are not permitted. The radial force must be applied to the gear unit as closely as possible.

www.nord.com

B1000-GB-0713

-12-



3. Assembly instructions, storage, preparation, installation

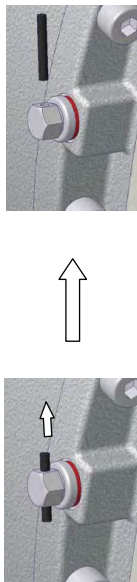

Figure 3-1: Activating the vent plug

Special pressure vents are supplied as loose parts. Before commissioning, the vent plug must be replaced with the pressure vent which is supplied as a loose part. This is achieved by screwing out the vent fitting and replacing it with the pressure vent and seal (refer to Section 6.2 for torque values). Double gear units consist of two single units and are equipped with 2 oil chambers and 2 pressure vents.



Figure 3-2: Removing vent plug and fitting the pressure vent

3.5 Installing the gear unit

The eyebolts screwed into the gear units must be used during installation. The safety notes in Section 1.4 must be observed.

The base and/or flange to which the gear unit is fitted should be vibration-free, torsionally strong and flat. The smoothness of the mating surface on the base or flange must be according to tolerance class K of DIN ISO 2768-2. All contamination to the bolting surfaces of gear unit and base and/or flange must be thoroughly removed.

The gear unit must be precisely aligned with the drive shaft of the machine in order to prevent additional forces from being imposed on the gear unit due to tension.

Welding of the gear unit is prohibited. The gear unit must not be used as the earth connection for welding work, as this may cause damage to the bearings and gear wheels.

The gear unit must be installed in the correct configuration (see Section 6.1) (UNIVERSAL gear unit types SI and SMI are independent of the configuration). Changes to the installation position after delivery require adjustment of the quantity of oil, and often other measures such as e.g. the installation of encapsulated roller bearings. **Damage may result if the stated installation position is not observed.**

All gear unit feet and/or all flange bolts on each side must be used. Bolts must have a minimum quality of 8.8. The bolts must be tightened to the correct torques (refer to Section 6.2 for torque values). Tension-free bolting must be ensured, particularly for gear units with a foot and flange.

www.nord.com

B1000-GB-0713

-11-

All position numbers are according to drawings and part lists in chapter 7 Parts list/Service kits



3. Assembly instructions, storage, preparation, installation

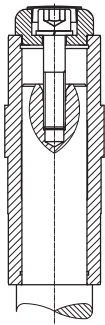

Figure 3-6: Gear unit mounted to shaft with a shoulder using the fastening element

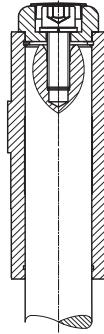

Figure 3-7: Gear unit mounted to shaft without a shoulder using the fastening element

A gear unit can be dismantled from a shaft with shoulder using the following device, for example.

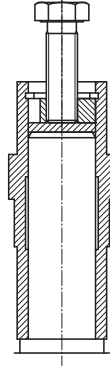

Figure 3-8: Dismantling using dismantling device

When mounting push-on gears with torque supports, the support must not be distorted. Tension-free mounting is aided by the rubber buffer (Option G and/or VG).

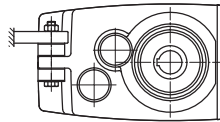

Figure 3-9: Mounting the rubber buffer (Option G and/or VG) on parallel shaft gear units

To fit the rubber buffer, tighten the screw fastening until there is no play between the contact surfaces when there is no load. Then turn the fastening nut (only applies for screw fastenings with adjusting threads) half a turn in order to pre-tension the rubber buffer. Greater pre-tension is not permissible. Secure the screw fastening from coming loose, e.g. with Loctite 242 or a second nut.



3. Assembly instructions, storage, preparation, installation



3.7 Fitting push-on gear units



Attention!

The bearings, gear wheels, shafts and housing may be damaged by incorrect fitting.

The push-on gear unit must be fitted onto the shaft using a suitable puller, which will not exert damaging axial forces on the gear unit. In particular, do not hit the gear unit with a hammer. Assembly and subsequent dismantling is aided by applying an anti-corrosive lubricant to the shaft before fitting (e.g. Nord Anti-Corrosion Art.No. 089 00099). Excess grease or anti-corrosion agent may escape after assembly and may drip off. Clean these points on the output shaft after a running-in time of approx. 24 hours. This escape of grease is not due to a leak in the gear unit.

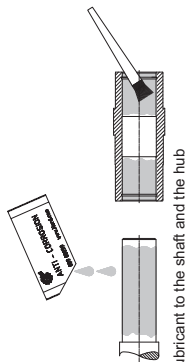

Figure 3-4: Applying lubricant to the shaft and the hub

Note!

The gear unit can be fitted to shafts with and without a shoulder using the fastening element (Option B). Tighten the bolt of the fastening element to the correct torque. (See Chapter 6.2 for torque values) For gear units with option H66, the factory-fitted closing cap must be removed before assembly.



For shaft mounted gear units with option H66 and fastening element (Option B) the pressed-in closing cap must be pushed out before fitting the gear unit. The pressed-in closing cap may be destroyed during dismantling. As standard a second closing cap is supplied as a loose spare part. After fitting the gear unit, fit the new / new condition closing cap as described in Section 3.11.



Figure 3-5: Removing the factory-fitted closing cap

All position numbers are according to drawings and part lists in chapter 7 Parts list/Service kits



3. Assembly instructions, storage, preparation, installation



3. Slide the shrink disc onto the hollow shaft until the outer clamping flange is flush with the hollow shaft. The shrink disc is easier to slide on if the bore of the inner ring is lightly greased.
4. Prior to mounting, grease the solid shaft only in the area which will later come into contact with the bronze bush in the hollow shaft of the gear unit. Do not grease the bronze bush, in order to prevent grease penetrating the area around the shrink connection.
5. The hollow shaft of the gear unit must be completely de-greased and **completely free of grease**.
6. In the area of the shrink connection the solid shaft of the machine must be degreased and **completely free of grease**.
7. Insert the solid shaft of the machine into the hollow shaft so as to completely fill the area around the shrink connection.
8. Position the clamping flange by gently tightening the bolts.
9. Tighten the bolts successively in a clockwise direction by several turns – not crosswise – with approx. ¼ rotation per turn. Tighten the bolts with a torque wrench to the torque indicated on the shrink disc.
10. When the tensioning bolts have been tightened, there must be an even gap between the clamping flanges. If this is not the case, the gear unit must be dismantled and the shrink disc connection checked for correct fit.

	Danger!
Risk of injury from incorrect mounting and dismantling of the shrink disc.	

Dismantling sequence:

1. Loosen the bolts successively in a clockwise direction by several turns with approx. ¼ rotation per turn. Do not remove the bolts from their thread.
2. Loosen the clamping flanges from the cone of the inner ring.
3. Remove the gear unit from the solid shaft of the machine.

3.9 Fitting the covers

	Danger!
Shrink discs and exposed rotating shaft ends require contact guards in order to prevent injuries. A cover (Option H and Option H66) can be used as a guard. If this does not achieve sufficient protection against contact according to the required protection type, the machinery and plant constructor must ensure this by means of special attached components.	

All fixing screws must be used and tightened to the correct torque. (See Section 6.2 for torque values) For covers with option H66, press in the new / new condition closing cap by tapping it lightly with a hammer.



3. Assembly instructions, storage, preparation, installation

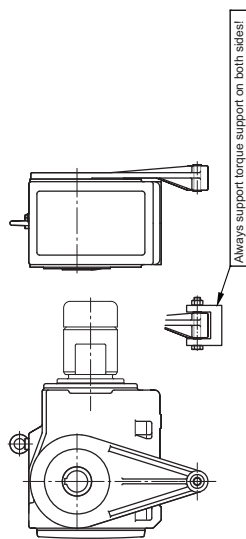

Figure 3-10: Attaching the torque support on bevel gear and worm gear units

Tighten the bolts on the torque support to the correct torque (see Section 6.2 for torque values) and secure to prevent loosening (e.g. Loctite 242, Loxeal 54-03).

3.8 Fitting shrink discs

Shrink disc type, Mat. No. and torque details for tensioning screws

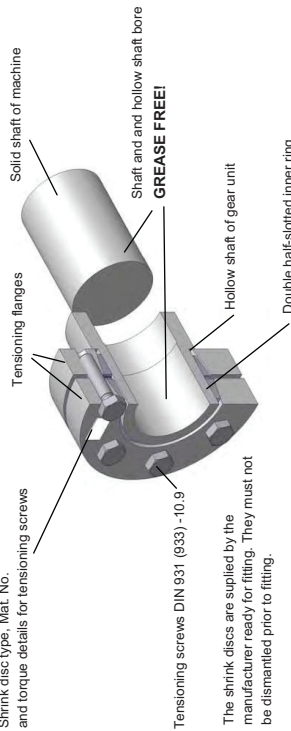

Figure 3-11: Hollow shaft with shrink disc

	Attention!
Do not tighten bolts if the solid shaft is not inserted!	

Assembly sequence:

1. Remove any transport securing devices.
2. Loosen but do not remove tightening bolt and tighten gently by hand until there is no play between the flanges and the inner ring.

All position numbers are according to drawings and part lists in chapter 7 Parts list/Service kits

3. Assembly instructions, storage, preparation, installation

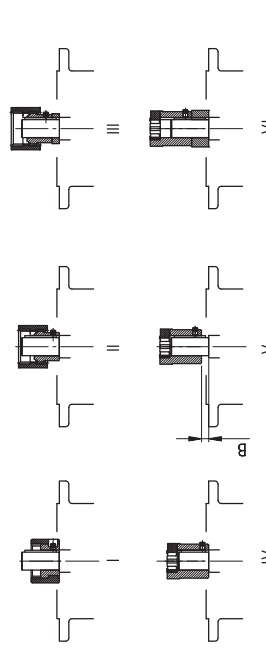

Figure 3-13: Fitting the coupling onto the motor shaft - various types of coupling

- I Gear coupling, one-part
- II Gear coupling, two-part
- III Gear coupling, two-part with spacer bush
- IV Claw coupling, two-part
- V Claw coupling, two-part, observe dimension B:
- VI Claw coupling, two-part with spacer bush

Standard helical gear unit:	SK0, SK01, SK20, SK25, SK30, SK33 (2-stage) SK010, SK200, SK250, SK300, SK330 (3-stage)
Dimension B (Fig. 3-13V)	IEC size 63 IEC size 71 B = 4,5mm B = 11,5 mm

3.11 Retrospective paintwork



Attention!

For retrospective painting of the gear unit, the radial seals, rubber elements, pressure venting valves, hoses, type plates, adhesive labels and motor coupling components must not come into contact with paints, lacquers or solvents, as otherwise components may be damaged or made illegible.

3. Assembly instructions, storage, preparation, installation



Figure 3-12: Fitting the covers, Option SH, Option H, and Option H66

3.10 Fitting a standard motor

The maximum permitted motor weights indicated in the table below must not be exceeded when attaching the motor to an IEC- /NEMA adapter

Maximum permitted motor weights														
IEC motor size	63	71	80	90	100	112	132	160	180	200	225	250	280	315
NEMA Motor size	56C	143T	145T	182T	184T	210T	250T	280T	324T	326T	365T			
Max. motor weight [kg]	25	30	40	50	60	80	100	200	250	350	500	700	1000	1500

Assembly procedure to attach a standard motor to the IEC adapter (Option IEC)/NEMA adapter

1. Clean motor shaft and flange surfaces of motor and IEC /NEMA adapter and check for damage. Mounting dimensions and tolerances of the motor must conform to DIN EN 50347/NEMA MG1 Part 4.
2. Push the coupling sleeve onto the motor shaft so that the motor parallel key engages into the groove in the sleeve on tightening.
3. Tighten the coupling sleeve on the motor shaft in accordance with the motor manufacturer's instructions until it touches the collar. With motor sizes 90, 160, 180 and 225, any spacer bushes must be positioned between the coupling sleeve and the collar. With standard helical gear units, dimension B between the coupling sleeve and the collar must be observed (see Figure 3-13). Certain **NEMA adapters** require the adjustment of the coupling in accordance with the specifications indicated on the adhesive plate.
4. If the coupling half contains a threaded pin, the coupling must be secured axially on the shaft. The threaded pin must be coated prior to use with a securing lubricant e.g. Loctite 242, Loxeal 54-03 and tightened to the correct torque. (See Chapter 6.2 for torque values)
5. Sealing of the flange surfaces of the motor and the IEC /NEMA adapter is recommended if the motor is installed outdoors or in a humid environment. **The flange surfaces** of motor and adapter must be completely coated with **surface sealant** Loctite 574 or Loxeal 58-14 prior to mounting so that the flange seals after mounting.
6. Mount the motor to the IEC /NEMA adapter, do not forget to fit the gear rim or the sleeve. (See Figure 3-13)
7. Tighten the IEC /NEMA adapter bolts to the correct torque. (See Chapter 6.2 for torque values)

All position numbers are according to drawings and part lists in chapter 7 Parts list/Service kits



3. Assembly instructions, storage, preparation, installation



3.12 Fitting the cooling coil to the cooling system

Cutting ring screw threads (see Item 1, Figs. 3-14) are located at the casing cover for the connection of a pipe with an external diameter of 10 mm according to DIN 2353. **Remove the drain plug from the screw neck prior to assembly to avoid any contamination of the cooling system.** The screw necks should be connected with the coolant circuit, which must be provided by the operator. The flow direction of the coolant is irrelevant. **Make sure not to twist the screw necks during or after assembly** as the cooling coil may be damaged (see Item 3, Fig. 3-14). You must ensure that no external forces act on the cooling coil.

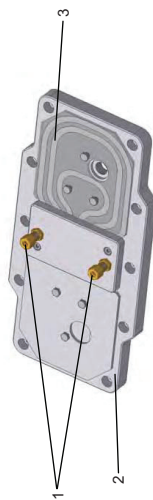

Figure 3-14: Cooling cover



Danger!

The pressure released from the cooling circuit before carrying out any work on the gear unit.



4. Commissioning



4. Commissioning

4.1 Checking the oil level

The oil level must be checked prior to commissioning. See Section 5.2.

4.2 Activating the automatic lubricant dispenser

Some gear unit types with standard motor (Option IEC/NEMA) have an automatic lubricant dispenser for the rolling bearings. This dispenser must be activated prior to commissioning. The cartridge case cover has a red information sign for the activation of the lubricant dispenser.

Activating the Automatic Lubricant Dispenser:

1. Loosen and remove cylinder bolts M8x16 (1)
2. Lift off cartridge case cover (2)
3. Insert activation screw (3) into the lubricant dispenser (5) until the lug (4) breaks off at the defined fracture point
4. Refit cartridge case cover (2) and fasten using cylinder bolt (1). (See Chapter 6.2 for torque values)
5. Mark activation date on the adhesive plate (6) indicating month/year

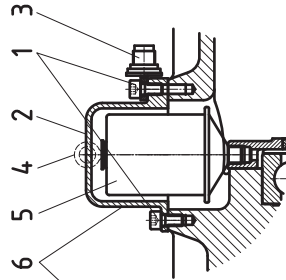

Attention!

Screw in the activation screw until the lug breaks off before commissioning the gear unit.

Dispensing time: 12 Months

Month	Activation date	Year
1	2	3
4	5	6
7	8	9
10	11	12
13	14	15

Figure 4-1: Activating the automatic lubricant dispenser with standard motor mounting

All position numbers are according to drawings and part lists in chapter 7 Parts list/Service kits



4. Commissioning



4.3 Operation with lubricant cooling

Water cooling



Caution!

The drive may only be commissioned after the cooling spiral has been connected to the cooling circuit, and the cooling circuit has been put into operation.

The coolant must have a similar thermal capacity as water (specific thermal capacity at 20°C c=4,18 kJ/kgK). Industrial water without any air bubbles or sediments is recommended as a coolant. The water hardness must be between 1° dH and 15° dH, and the pH value must be between pH 7.4 and pH 9.5. No aggressive liquids should be added to the coolant!

The **coolant pressure** must not exceed **8 bar**. The required **quantity of coolant** is **10 litres/minute**, and the **coolant inlet temperature** should not exceed 40°C, we recommend 10°C.

We also recommend fitting a pressure reducer at the coolant inlet to avoid any damage due to excessive pressure.

If there is a danger of frost the operator should add a suitable anti-freeze solution to the cooling water.

The **temperature of the cooling water** and the **cooling water flow rate** must be **supervised** and **ensured** by the operator.

Air/Oil cooler

This version and all important data concerning the air/oil cooler can be obtained from Catalogue G-1000, or contact the manufacturer of the cooling unit.

4.4 Running-in time for the worm gear unit



Note!

In order to achieve maximum efficiency of the worm gear unit, the gear unit must be subjected to a running-in period of approx. 25 h – 48 h under maximum load.

There may be a reduction in efficiency before the running-in period is complete.

4.5 Checklist

Checklist		Information – see Section
Object of the check	Checked on:	
Is the vent plug activated or the pressure vent screwed in?		Sec. 3.4
Does the required configuration conform with the actual installation?		Sec. 6.1
Are the external gear shaft forces within permitted limits (chain tension)?		Sec. 3.6
Is the torque support correctly fitted?		Sec. 3.7
Are contact guards fitted to rotating components?		Sec. 3.9
Is the automatic lubricant dispenser activated?		Sec. 4.2
Is the cooling cover connected to the cooling circuit?		Sec. 3.12/4.3



5. Service and Maintenance



5. Service and maintenance

5.1 Service and maintenance intervals

Service and Maintenance Intervals	Service and Maintenance Work	Information – see Section
At least every six months	- Visual inspection - Check for running noises - Check oil level - Re-grease (applicable only to free drive shaft / Option W and on agitator bearings / Option VL2 / VL3) - Replace automatic lubricator (for operating times < 8 h/day; a replacement interval for the lubricant dispenser of 1 year is permissible) (only with IEC/NEMA standard motors)	5.2 5.2 5.2 5.2 5.2
For operating temperatures up to 80°C Every 10000 operating hours at least every 2 years (The interval is double this if the unit is filled with synthetic products) For higher temperatures or extreme operating conditions (high humidity, aggressive environments and large temperature fluctuations) the oil change intervals must be halved.	- Change the oil - Clean or replace the vent plug.	5.2 5.2
Every 25000 operating hours, at least every 5 years At least every 10 years	- Replace shaft sealing rings if worn - Re-lubrication of the bearings in the gear unit - General overhaul	5.2 5.2 5.2

5.2 Service and maintenance work

Servicing and maintenance work must only be performed by qualified specialist personnel.

Installation and maintenance work must only be performed when gear units are at a standstill. The drive must be isolated and secured to prevent accidental start-up.

Visual inspection

The gear unit must be checked for leaks. In addition, the gear unit must be inspected for external damage and cracks in the hoses, hose connections and rubber buffers. Have the gear unit repaired in case of leaks, e.g. dripping gear oil or cooling water, damage or cracks. Please contact the NORD service department.

Note!



Shaft sealing rings are rubbing seals and have sealing lips made from an elastomer material. These sealing lips are lubricated with a special grease at the factory. This reduces the wear due to their function and ensures a long service life. An oil film in the region of the rubbing sealing lip is therefore normal and is not due to leakage.

All position numbers are according to drawings and part lists in chapter 7 Parts list/Service kits



5. Service and Maintenance



Check for running noises

If the gear unit produces unusual running noises and/or vibrations, this could indicate damage to the gear unit. In this case the gear should be shut down and a general overhaul carried out.

Check the oil level

Section 6.1 describes the versions and the corresponding oil level screws. With double gear units, the oil level must be checked on both units. The pressure vent must be at the position marked in Section 6.1.

The oil level does not need to be checked on gear units without oil level screw (see Section 6.1). Gear unit types that are not supplied full of oil must be filled before the oil level is checked. (see "Changing the oil")

Checking the oil level:

1. The oil level may only be checked when the gear unit is **at a standstill and has cooled down**. The gear unit must be secured to prevent accidental switch-on.
2. The oil level screw corresponding to the version must be screwed out. (See Section 6.1)

Note!

At the first oil level check a small amount of oil may escape, as the oil level may be below the lower edge of the oil level hole.

3. **Gear units with oil level screw:** The maximum oil level is the lower edge of the oil level hole. The minimum oil level is 4 mm below the oil level hole. If the oil level is too low, this must be corrected using the correct type of oil. An oil level glass is available instead of the oil level screw

4. **Gear units with an oil level vessel:** The oil level must be checked **in the oil level vessel** with the aid of the dipstick plug (thread G1 1/4). The oil level must be between the upper and lower mark when the dipstick is completely screwed in (see Fig. 5-2). The oil level must be corrected with the correct type of oil if necessary. These gearboxes may only be operated in the configuration stated in Section 6.1.

5. The oil level screw or the cap screw with dipstick and all other loosened screws must be correctly re-tightened.

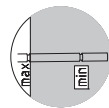

Figure 5-2: Check the oil level with a dipstick



5. Service and Maintenance



Regreasing

Some gear unit designs (free drive shaft, Option W, agitator designs VL2 and VL3) are equipped with a regreasing device.

For agitator versions VL2 and VL3, the vent screw located opposite to the grease nipple must be unscrewed before regreasing. Grease should be injected until a quantity of 20-25g escapes from the vent hole. After this, the vent plug must be reinserted and tightened.

For Option W and some IEC adapters, the outer roller bearing must be regreased with approx. 20-25g of grease via the grease nipple provided

Recommended grease: Peiama GHY 133N (see Section 6.4; Klüber Lubrication).

Replacing the automatic lubricant dispenser

Screw-off the cartridge case cover (2), (see Fig. 4-1). The lubrication dispenser (5) is screwed out and replaced with a new component (Part No. 283.0100). Then activate (see Chapter 4.2!)

Changing the oil

The figures in Section 6.1 show the oil drain screw, the oil level screw and the pressure vent screw for various designs.

Sequence:

1. Place the drip tray below the oil drain screw or the oil drain cock
2. Completely remove oil level screw, screwed sealing plug with dipstick if an oil level tank is being used and oil drain screw.



Danger!

Warning: Hot oil!

3. Drain all the oil from the gear unit.
4. If the screw lock coating of the oil drain screw or oil level screw is damaged in the thread, a new oil level screw must be used or the thread cleaned and coated with securing lubricant, e.g. Loctite 242, Loctite 54-03 prior to inserting. Check the sealing ring for damage. Replace with a new sealing ring in case of damage.
5. Support the seal ring, insert the oil drain screw into the hole and tighten to the correct torque! (See Section 6.2 for torque values)
6. Using a suitable filling device, refill with oil of the same type through the oil level hole until oil emerges from the oil level hole. (The oil can also be filled through the pressure vent screw or a sealing plug located higher than the oil level). If an oil level vessel is used, fill the oil through the upper inlet (thread G1 1/4) until the oil level is set as described in Section 5.2.
7. Wait at least 15 minutes, or at least 30 minutes if an oil level tank is used, and then check the oil level. Proceed as described in Section 5.2.

Note!

The oil does not need to be changed on gear units without oil level screw (see Section 6.1). These gear units are lubricated for life.

Standard helical gear units have no oil level screw. Here, the oil is topped up through the pressure vent bolt using the quantities listed in the table in Section 6.5.



All position numbers are according to drawings and part lists in chapter 7 Parts list/Service kits



5. Service and Maintenance



Cleaning or replacing the vent plug

Unscrew the vent screw and thoroughly clean it (e.g. with compressed air) and fit the vent screw in the same place, if necessary, use a new vent screw with a new sealing ring.

Replacing the shaft sealing ring

Shaft sealing rings are rubbing seals made from an elastomer material and according to their principle are subject to natural wear. The wearing life of shaft sealing rings depends on many factors and cannot be calculated in advance. Once the shaft sealing ring has reached the end of its service life, the oil film in the region of the sealing lip increases and a measurable leakage with dripping oil occurs. **The shaft sealing ring must then be replaced.** To reduce the risk of leaks due to worn shaft sealing rings we recommend that as a precaution, the shaft sealing rings are replaced after every 25,000 operating hours or every 5 years. The space between the sealing lip and the protective lip must be filled approximately 50% with grease on fitting (recommended grease: PETAMO GHY 133N). Take care that after fitting, the new shaft sealing ring does not run in the old wear track.

Re-lubricating bearings

For bearings which are not oil-lubricated and whose holes are completely above the oil level, replace the roller bearing grease (recommended grease: PETAMO GHY 133N). Please contact the NORD service department.

General overhaul

The gear units must be completely dismantled. The following work must be carried out:

- Clean all gear unit components
- Examine all gear unit components for damage
- All damaged components must be replaced
- All roller bearings must be replaced
- Replace back stops if fitted
- Replace all seals, radial seals and Nilos rings
- Replace plastic and elastomer components of the motor coupling

The general overhaul must be carried out by qualified personnel in a specialist workshop with appropriate equipment in observance of national regulations and laws. We recommend that the general overhaul is carried out by the NORD service department.



6. Appendix



6. Appendix

6.1 Versions and maintenance

Explanation of symbols for the following version illustrations:

- Vent
- Oil level
- Oil drain



Note!

SK 320, SK 172, SK 272, SK 372K, SK 273 and SK373 as well as SK 01282 NB, SK 0282 NB, SK 1382 NB and UNIVERSAL / Minibloc gear units are lubricated for life. These gear units do not have an oil filler screw.

UNIVERSAL / MiniBloc worm gear units

NORD UNIVERSAL / MiniBloc worm gear units are suitable for all installation positions. They have an oil filler which is independent of the version.

As an option, types SI and SMI can be equipped with a vent screw. Gear units with vents must be installed in the stated position (see section 6.5)

Types SI, SMI, S, SM and SU as 2-stage gear unit types and types SI, SMI as worm gear units for direct motor mounting have an oil filler which depends on the version and must be installed in the stated position.

All position numbers are according to drawings and part lists in chapter 7 Parts list/Service kits



6. Appendix



Parallel shaft gear units with oil level vessel

The following applies for SK 9282, SK 9382, SK 10282, SK 10382, SK 11282, SK 11382, parallel gear units and SK 12382. In the M4 configuration with oil level vessels:

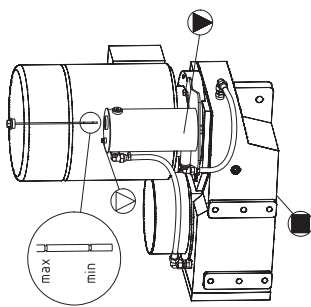
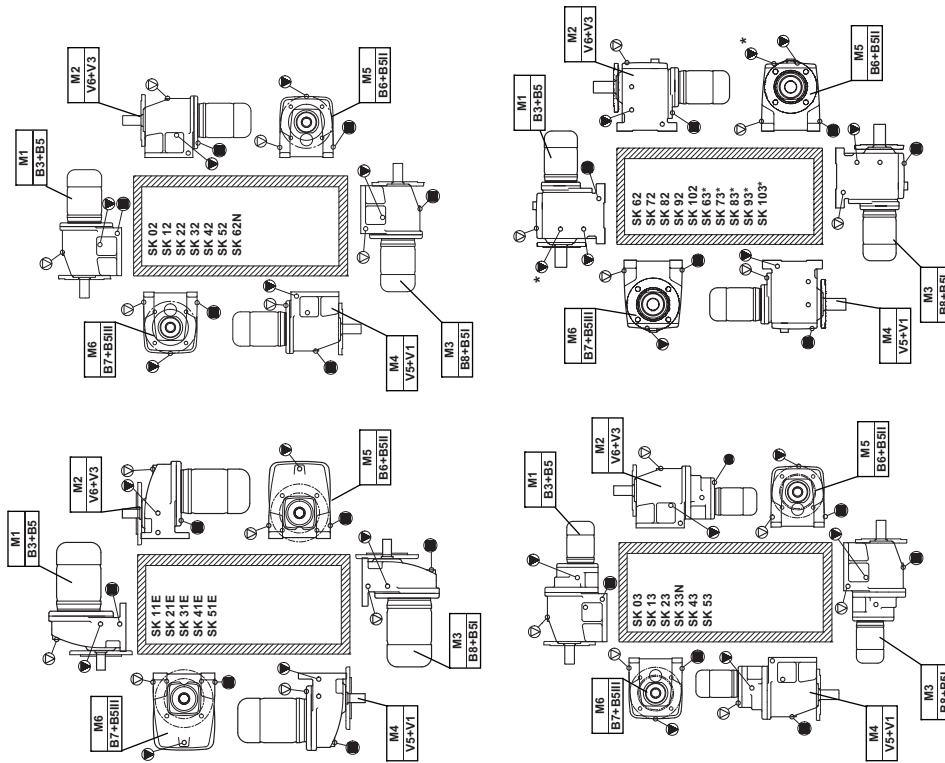
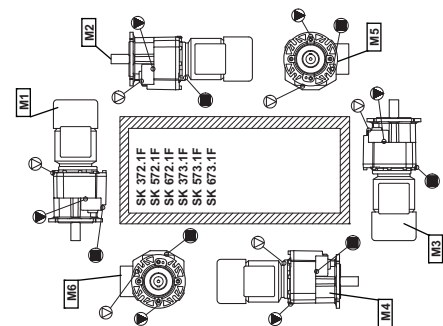
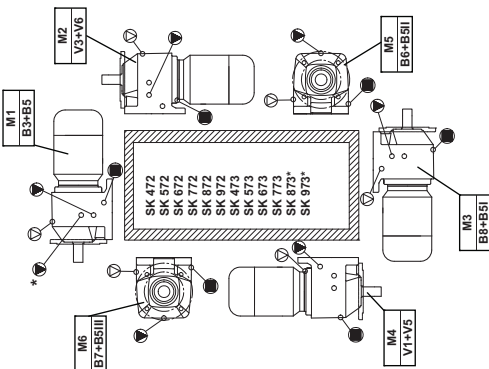
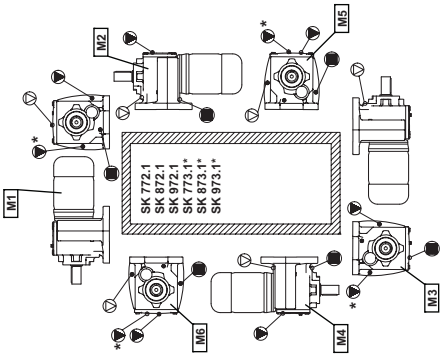
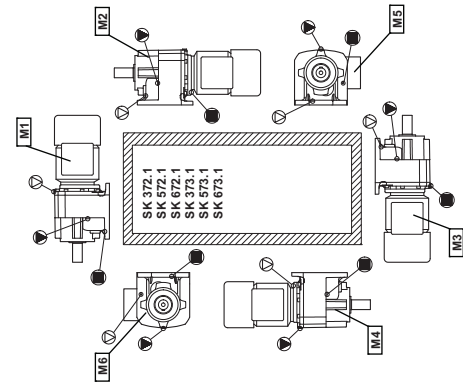
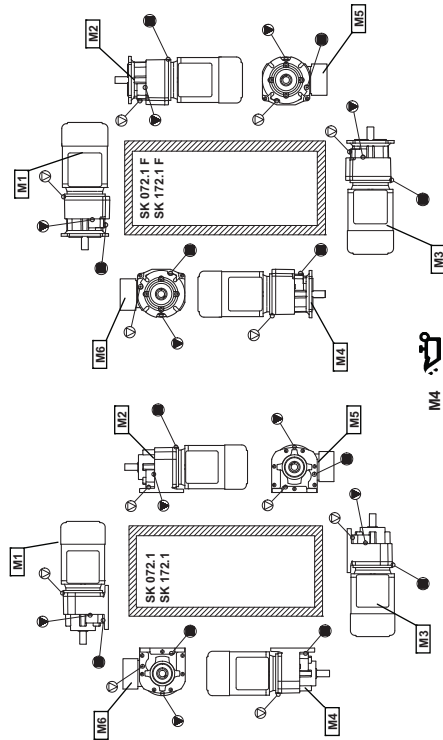
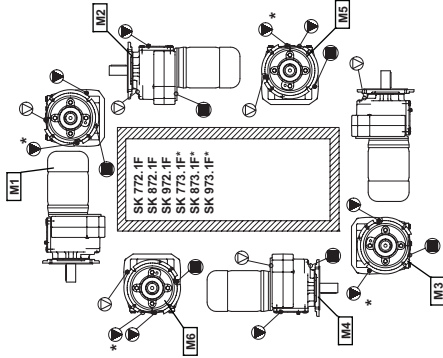

Figure 6-1: Oil level check with oil level tank



8 Appendix

All position numbers are according to drawings and part lists in chapter 7 Parts list/Service kits



All position numbers are according to drawings and part lists in chapter 7 Parts list/Service kits

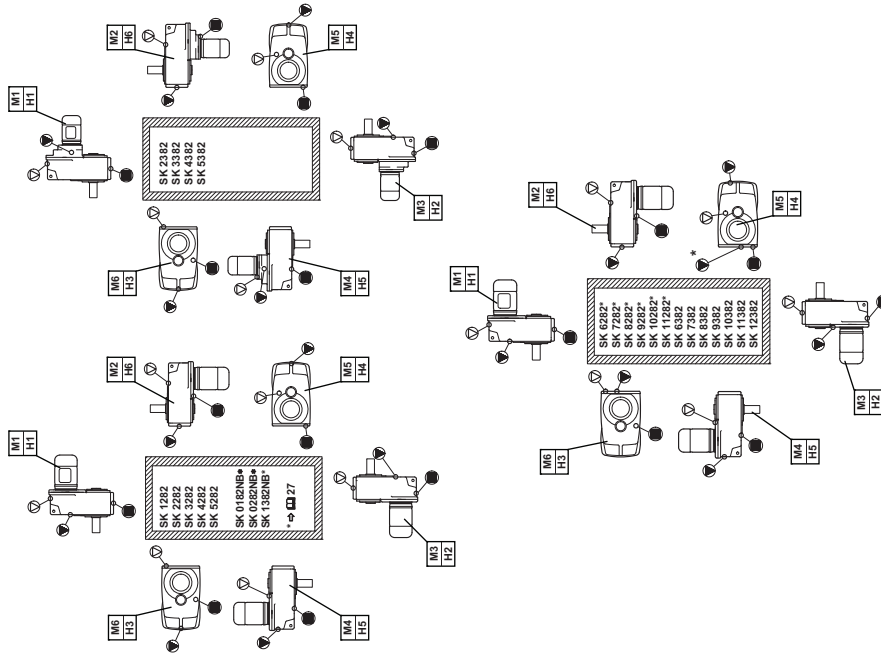

www.nord.com

B1000-0713

-32-

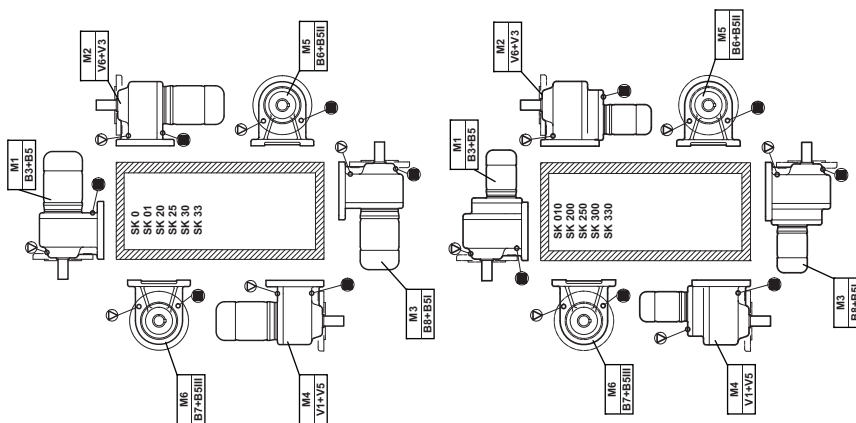

-31-

B1000-0713

www.nord.com

8 Appendix

All position numbers are according to drawings and part lists in chapter 7 Parts list/Service kits

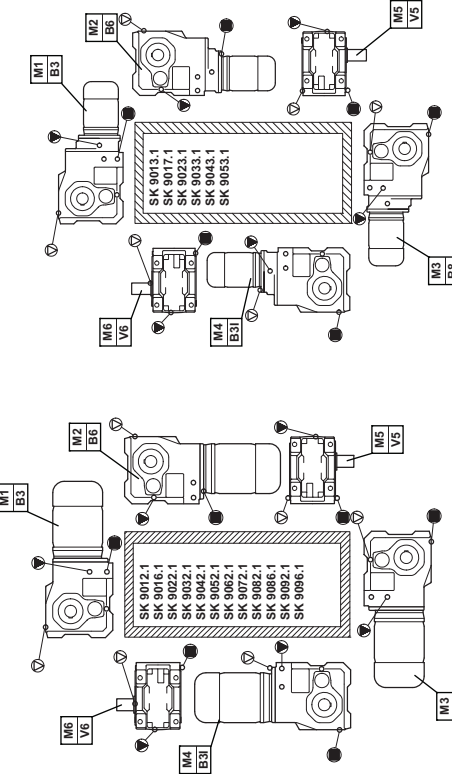
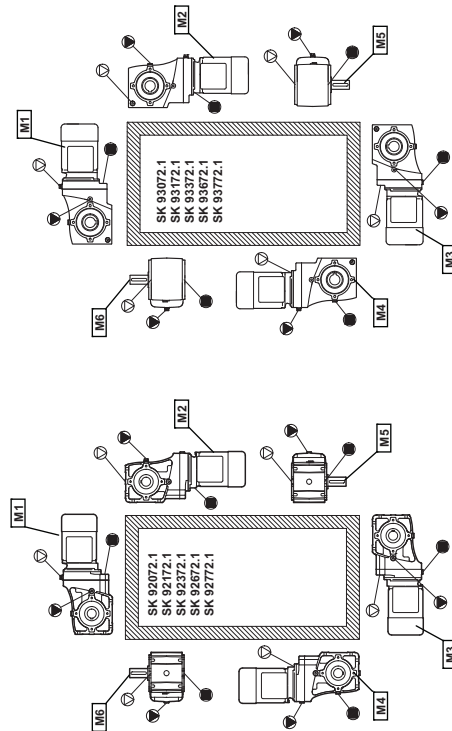
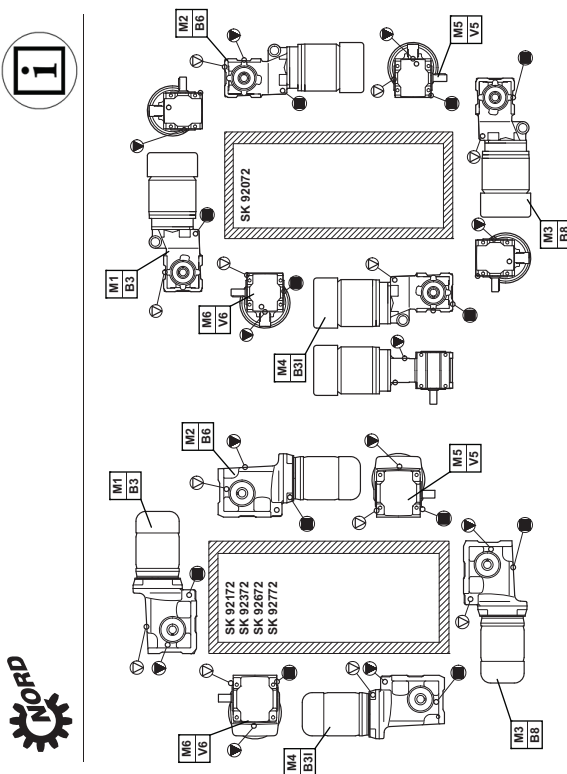
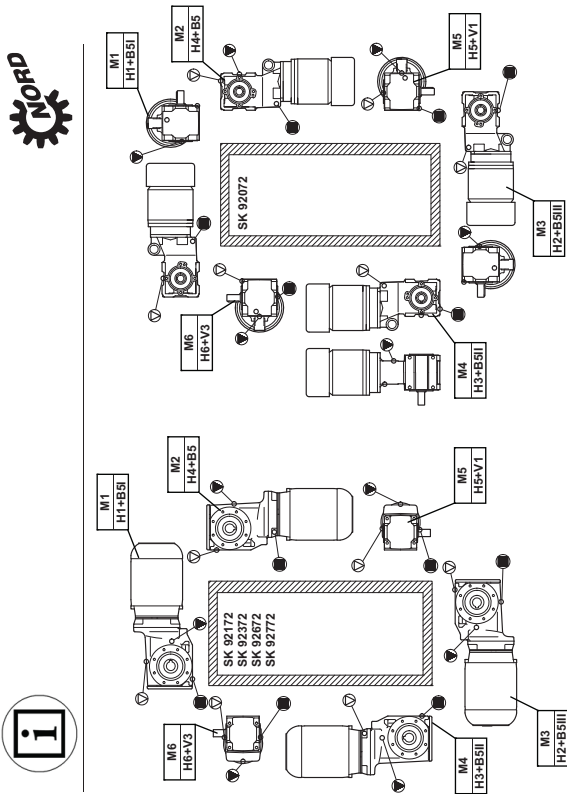

www.nord.com

B1000-0713

-34-

-33-

B1000-0713

www.nord.com

All position numbers are according to drawings and part lists in chapter 7 Parts list/Service kits

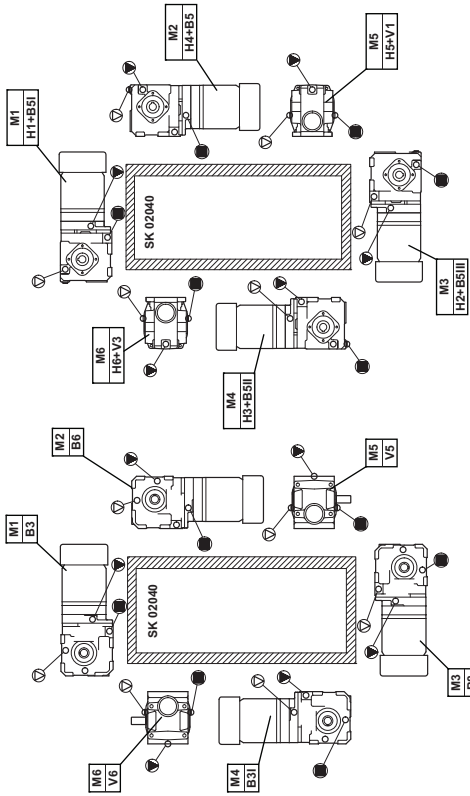
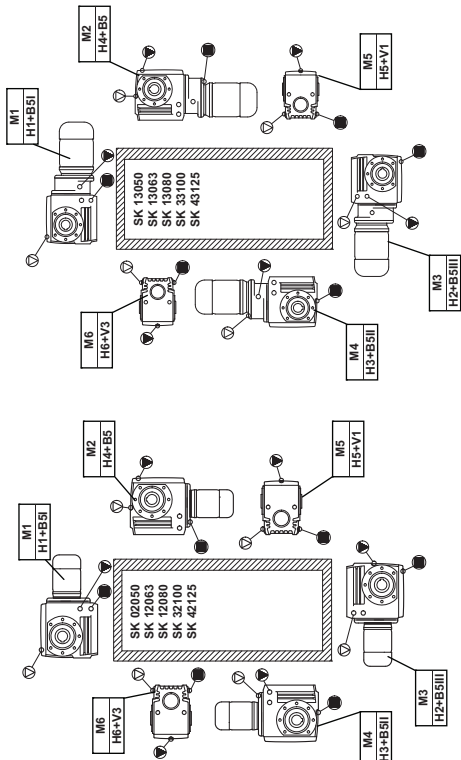

www.nord.com

B1000-0713

-36-

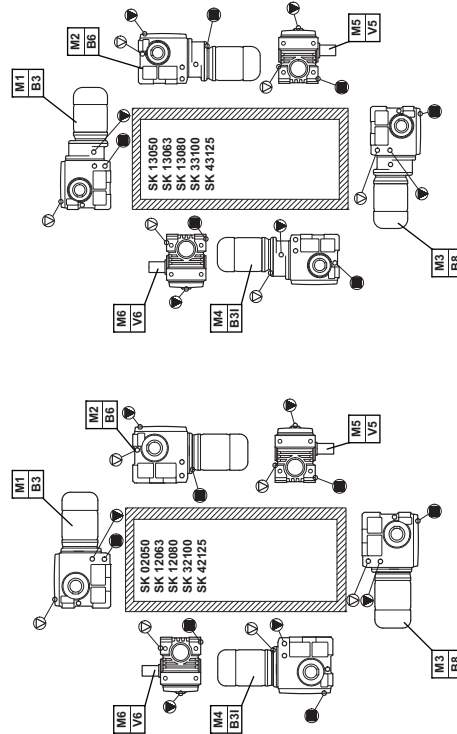
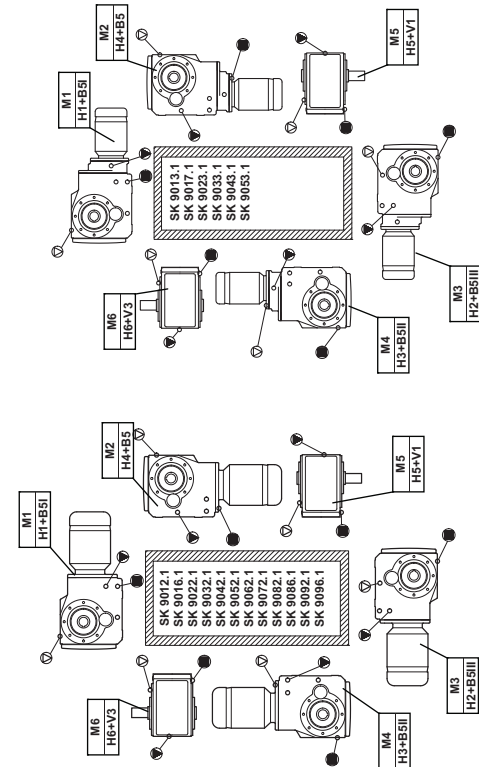

-35-

B1000-0713

www.nord.com

All position numbers are according to drawings and part lists in chapter 7 Parts list/Service kits



6. Appendix



6.2 Torque values

Size	Bolt Torques [Nm]			
	Screw connections in the strength classes	10.9	12.9	Sealing screws
M4	8.8	5	6	-
M5	6.4	9	11	-
M6	11	16	19	-
M8	27	39	46	11
M10	53	78	91	17
M12	92	135	155	27
M16	230	335	390	-
M20	460	660	770	-
M24	790	1150	1300	80
M30	1600	2250	2650	170
M36	2780	3910	4710	-
M42	4470	6290	7540	-
G1 1/4	-	-	-	20



- SK 1S32 – SK 1S63
- SK 1SU32 – SK 1SU63
- SK 1SM31 – SK 1SM63
- SK 1SI31 – SK 1SI75
- SK 1SIS31 – SK 1SIS75
- SK 1SMI31 – SK 1SMI75
- SK 1SID31 – SK 1SID75
- SK 1SIS-D31 – SK 1SIS-D63
- SK 1SMID31 – SK 1SMID75
- SK 2S32NB – SK 2S63NB
- SK 2SU32NB – SK 2SU63NB
- SK 2SM40 – SK 2SM63
- SK 2SIS-D40 – SK 2SIS-D63
- SK 2SID40 – SK 2SID63
- SK 2SMID40 – SK 2SMID63

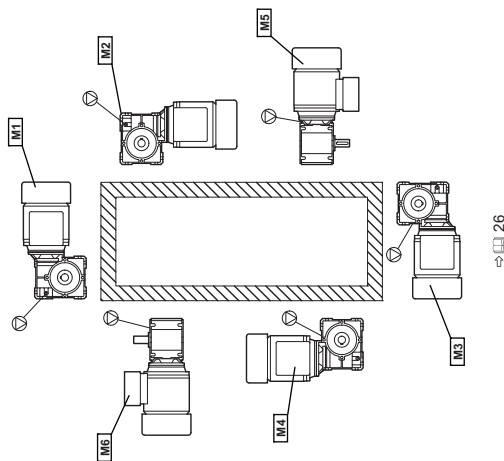

6.3 Troubleshooting

Fault	Gear unit malfunctions	
	Possible cause	Remedy
Unusual running noises, vibrations	Oil too low or bearing damage or toothed wheel damage	Consult NORD Service
Oil escaping from gear unit or motor	Defective seal	Consult NORD Service
Oil escaping from pressure vent	Incorrect oil level or incorrect, contaminated oil or unfavourable operating conditions	Oil change Use oil expansion tank (Option OA)
Gear unit becomes too hot	Unfavourable installation conditions or gear unit damage	Consult NORD Service
Shock when switched on, vibrations	Defective motor coupling or loose gear unit mounting or defective rubber element	Replace elastomer gear rim, tighten motor and gear unit fastening bolts, replace rubber element
Drive shaft does not rotate although motor is running	Fracture in gear unit or defective motor coupling or shrink disc slippage	Consult NORD Service



Attention!

Warning: shut down the gear unit immediately should any of the above faults occur

All position numbers are according to drawings and part lists in chapter 7 Parts list/Service kits



6. Appendix



6.4 Lubricants

With the exception of type SK 11282, SK 11382, SK 12382 and SK 9096.1 gear units, all gear units are filled with lubricant ready for operation in the required installation position when delivered. This initial filling corresponds to a lubricant from the column for the ambient temperatures (normal version) in the lubricant table.

Roller bearing greases

This table shows comparable roller bearing greases from various manufacturers. The manufacturer can be changed for a given grease type. Getriebebau NORD must be contacted in case of change of grease type or ambient temperature range, as otherwise no warranty for the functionality of our gear units can be accepted.

Lubricant type	Ambient temperature	bp	Castrol	Fuchs	KLUBER	Mobil	Shell
Mineral oil-based grease	-30 ... 60°C	Engr grease LS 2 Engr grease LS-EP 2	Longtime PD 2	RENOLIT SP 2 RENOLIT LZR 2 H RENOLIT JP 1619	-	Mobilux EP 2	Gladia S2 V160 Z
Synthetic grease	-25 ... 80°C	Engr grease S1 Z202	Optitemp LG 2 Tribol 4747	RENOLIT HLT 2 RENOLIT LST 2 PLANTOGEL 2 S	GETALUS GHY 133 N Klubberplex BEM 41-132 Klubberbo M 7242	MultiTemp SHC 32	Cassida EP52
Biodegradable grease	-25 ... 40°C	Biogrease EP 2	-	-	-	Mobil SHC Grease 102 EAL	Naturelle Grease EP2
Foodstuff-compatible grease	-25 ... 40°C	-	Oberon UIF 2	RENOLIT G 7 FG 1	Klubberynth UH1 14-151	Mobilgrease PM 222	Cassida RL52



6. Appendix



Lubricant table

This table shows comparable lubricants from various manufacturers. The manufacturer can be changed within a particular viscosity or lubricant type. Getriebebau NORD must be contacted in case of change of viscosity or lubricant type, as otherwise no warranty for the functionality of our gearboxes can be accepted.

Lubricant type	Details on type plate	DN (ISO) / Ambient temperature	bp	Castrol	Fuchs	KLUBER	Mobil	Shell
Mineral oil	CLP 680	ISO VG 680 0...40°C	Engral GR-XP 680 Optigear BM 680	Alpha EP 680 Alpha SP 680 Optigear BM 680	RENOLIN CLP 680 Plus	Klubberoil GEM 1-680 N	Mobilgear 600 XP 680	Omala S2 G 680
	CLP 220	ISO VG 220 -10...40°C	Engral GR-XP 220	Alpha EP 220 Alpha SP 220 Optigear BM 220	RENOLIN CLP 220 Plus	Klubberoil GEM 1-220 N	Mobilgear 600 XP 220	Omala S2 G 220
	CLP 100	ISO VG 100 -15...25°C	Engral GR-XP 100	Alpha EP 100 Alpha SP 100 Optigear BM 100	RENOLIN CLP 100 Plus	Klubberoil GEM 1-100 N	Mobilgear 600 XP 100	Omala S2 G 100
	CLP PG 680	ISO VG 680 -25...40°C	Alphasyn GS Tribol 800/680	Alphasyn GS Tribol 800/680	RENOLIN PG 680	Klubberynth GH 6-680	Mobil Gygoyle 680	Omala S4 WE 680
Synthetic oil (Polyglycol)	CLP PG 220	ISO VG 220 -25...80°C	Engral SO-XP 220	Alphasyn PG 220	RENOLIN PG 220	Klubberynth GH 6-220	Mobil Gygoyle 220	Omala S4 WE 220
	CLP HC 460	ISO VG 460 -30...80°C	-	Alphasyn EP Tribol 1510/460	RENOLIN Unisyn CLP 460	Klubberynth GEM 4-460 N	Mobil SHC 634	Omala S4 GX 460
Synthetic oil (Hydrocarbon)	CLP HC 220	ISO VG 220 -40...80°C	-	Alphasyn EP Tribol 1510/220 Tribol 1510/220 Synthetic X 220	RENOLIN Unisyn CLP 220	Klubberynth GEM 4-220 N	Mobil SHC 630	Omala S4 GX 220
	CLP E 680	ISO VG 680 -5...40°C	-	Tribol Bio Top 1418/220	PLANTOGEAR 680 S	-	-	-
Bio-degradable oil	CLP E 220	ISO VG 220 -5...40°C	-	-	PLANTOGEAR 220 S	Klubberynth GEM 2-220	-	Naturelle Gear Fluid EP 220
	CLP PG H1 680	ISO VG 680 -5...40°C	-	Tribol FoodProof 1800/680	-	Klubberynth UH1 6-680	Mobil Gygoyle 680	Cassida Fluid PG 680
Food grade oil	CLP PG H1 220	ISO VG 220 -25...40°C	-	Tribol FoodProof 1800/220	-	Klubberynth UH1 6-220	Mobil Gygoyle 220	Cassida Fluid WG 220
	CLP HC H1 680	ISO VG 680 -5...40°C	-	Optilub GT 680	GERALYN SF 680	Klubberoil 4 UH1-680 N	-	Cassida Fluid GL 680
	CLP HC H1 220	ISO VG 220 -25...40°C	-	Optilub GT 220	GERALYN SF 220	Klubberoil 4 UH1-220 N	Mobil SHC Cibus 220	Cassida Fluid GL 220
	CLP PG H1 220	ISO VG 220 -25...40°C	-	Engr grease LS-EP 100	Longtime PD 00 Tribol DUBPLEX 3020/1000-00	MCSOLUBE EP 00 Klubberynth GE 46-1200	Mobil Grease LBZ Mobil Gygoyle Grease 00	Cassida Fluid EP LUF 2

All position numbers are according to drawings and part lists in chapter 7 Parts list/Service kits



6. Appendix



6.5 Lubricant quantities

Note!

After changing the lubricant, and in particular after the initial filling, the oil level may change during the first few hours of operation, as the oil galleries and hollow spaces only fill gradually during operation. The oil level is still within the permissible tolerance.

If at the express request of the customer, an oil inspection glass is installed at an additional charge, we recommend that the customer corrects the oil level after an operating period of approx. 2 hours, so that when the gear unit is at a standstill and has cooled down, the oil level is visible in the inspection glass. Only then, is it possible to check the oil level by means of the inspection glass.

The filling quantities stated in the following tables are for guidance only. The precise quantities vary depending on the exact gear ratio. When filling, always observe the oil level screw hole as an indicator of the precise quantity of oil.



* Type SK11282, SK11382, SK12382 and SK 9096. 1 gear units are normally supplied without oil.



Type	Oil level screw hole											
	M1	M2	M3	M4	M5	M6	M1	M2	M3	M4	M5	M6
SK1E	0.60	1.20	1.20	1.00	1.00	1.00	0.50	0.30	0.35	0.50	0.30	0.40
SK2E	1.10	2.70	2.20	2.30	1.70	1.70	0.80	1.30	1.65	1.10	2.00	2.00
SK3E	1.70	2.60	3.30	2.90	2.60	2.60	1.00	2.60	2.60	1.60	3.30	3.30
SK4E	2.20	4.40	4.70	4.00	3.40	3.40	1.60	3.50	4.10	3.00	3.80	3.80
SK102	6.50	15.00	13.00	16.00	15.00	15.00	7.00	15.00	14.00	18.50	16.00	16.00
SK122	10.00	23.00	18.00	26.00	23.00	23.00	10.00	23.00	18.50	26.00	23.00	23.00
SK142	14.00	35.00	27.00	44.00	32.00	32.00	15.00	37.00	29.00	45.00	34.50	34.50
SK162	25.00	73.00	47.00	76.00	52.00	52.00	26.00	73.00	47.00	78.00	52.00	52.00
SK182	36.00	79.00	85.00	102.00	71.00	71.00	40.00	81.00	66.00	104.00	72.00	72.00
SK202	0.30	1.00	0.80	0.90	0.60	0.60	0.50	0.80	0.90	1.10	0.80	0.80
SK222	0.60	1.25	1.10	1.20	0.70	0.70	0.85	1.20	1.20	1.20	0.95	0.95
SK242	1.30	2.40	2.30	2.35	1.60	1.60	1.50	2.60	2.50	2.80	2.80	2.80
SK262	1.60	2.90	3.20	3.70	2.30	2.30	2.30	3.40	3.50	4.40	2.60	2.60
SK282	3.00	5.60	5.20	6.60	3.60	3.60	3.50	5.70	5.00	6.10	4.10	4.10
SK302	4.50	8.70	7.70	8.70	6.00	6.00	5.20	8.40	7.00	8.90	6.70	6.70
SK322	13.00	14.50	14.50	16.00	15.00	13.00	13.50	14.00	15.50	16.00	14.00	14.00
SK342	20.50	20.00	22.50	27.00	20.00	20.00	22.00	22.50	23.00	27.50	20.00	20.00
SK362	30.00	31.00	34.00	37.00	33.00	33.00	31.00	34.00	35.00	40.00	34.00	34.00
SK382	53.00	70.00	59.00	72.00	49.00	49.00	53.00	70.00	59.00	74.00	49.00	49.00
SK402	74.00	71.00	74.00	97.00	67.00	67.00	69.00	78.00	78.00	99.00	67.00	67.00

All position numbers are according to drawings and part lists in chapter 7 Parts list/Service kits



	M1	M2	M3	M4	M5	M6	M1	M2	M3	M4	M5	M6						
⇒ 6.1 SK072.1	0.35	0.50	0.50	0.50	0.50	0.50	B3	V6	B8	V5	B6	B7	B5	V3	B51	V1	B51l	B51ll
SK172	0.60	1.00	1.00	1.00	1.00	1.00	SK772	0.60	1.00	1.00	1.00	1.00	0.60	1.00	1.00	1.00	1.00	1.00
SK472	1.00	1.90	1.90	2.00	1.80	1.80	SK772	1.00	1.90	1.90	2.00	1.80	1.00	1.90	1.90	2.00	1.80	1.80
SK672	1.40	3.40	3.10	3.15	1.45	3.15	SK772	1.40	3.40	3.10	3.15	1.45	3.15	3.40	2.70	2.80	1.25	2.70
SK872	3.70	9.60	9.10	7.30	4.70	8.00	SK772	3.70	9.60	9.10	7.30	4.70	8.00	3.50	9.00	7.90	7.70	3.90
SK972	6.50	16.00	15.70	14.70	8.50	14.00	SK772	6.50	16.00	15.70	14.70	8.50	14.00	6.50	15.00	13.00	13.50	6.50



	M1	M2	M3	M4	M5	M6	M1	M2	M3	M4	M5	M6	
⇒ 6.1 SK072.1	0.16	0.32	0.21	0.23	0.18	0.20	SK972.1 F	0.16	0.32	0.21	0.23	0.18	0.20
SK172.1	0.27	0.89	0.42	0.46	0.32	0.39	SK972.1 F	0.27	0.89	0.42	0.46	0.32	0.39
SK372.1	0.45	1.05	0.75	1.00	0.60	0.65	SK972.1 F	0.45	1.05	0.75	1.00	0.60	0.65
SK572.1	0.75	1.90	1.50	2.00	1.10	1.15	SK972.1 F	0.75	1.90	1.50	2.00	1.10	1.15
SK672.1	1.10	2.80	2.15	2.70	1.55	1.65	SK972.1 F	1.10	2.80	2.15	2.70	1.55	1.65
SK772.1	1.35	3.65	2.25	3.15	1.35	2.15	SK972.1 F	1.35	3.65	2.25	3.15	1.35	2.15
SK872.1	3.20	8.00	5.30	7.00	2.80	4.60	SK972.1 F	3.20	8.00	5.30	7.00	2.80	4.60
SK972.1	4.50	12.90	8.10	12.70	4.60	7.80	SK972.1 F	4.50	12.90	8.10	12.70	4.60	7.80
SK772.1VL	2.00	3.65	2.25	3.15	1.35	2.15	SK772.1VL F	2.00	3.65	2.25	3.15	1.35	2.15
SK872.1VL	5.00	8.00	5.30	7.00	2.80	4.60	SK872.1VL F	5.00	8.00	5.30	7.00	2.80	4.60
SK972.1VL	8.50	12.90	8.10	12.70	4.60	7.80	SK972.1VL F	8.50	12.90	8.10	12.70	4.60	7.80



	M1	M2	M3	M4	M5	M6	M1	M2	M3	M4	M5	M6	
⇒ 6.1 SK20	0.55	1.00	0.55	1.00	0.55	0.55	SK20 F	0.35	0.60	0.35	0.60	0.35	0.35
SK0	0.13	0.22	0.13	0.22	0.13	0.13	SK0 F	0.13	0.22	0.13	0.22	0.13	0.13
SK01	0.22	0.38	0.22	0.38	0.22	0.22	SK01 F	0.22	0.38	0.22	0.38	0.22	0.22
SK25	0.50	0.90	0.50	0.90	0.50	0.50	SK25 F	0.50	0.90	0.50	0.90	0.50	0.50
SK33	0.80	1.60	1.00	1.60	0.80	1.00	SK33 F	1.00	1.60	1.00	1.60	0.80	1.00
SK30	0.80	1.40	0.70	1.40	0.70	0.70	SK30 F	0.80	1.40	0.70	1.40	0.70	0.70
SK300	1.40	1.50	1.40	1.50	1.40	1.40	SK300 F	1.40	1.50	1.40	1.50	1.40	1.40
SK330	1.50	1.58	1.50	1.58	1.50	1.50	SK330 F	2.00	1.58	1.50	2.80	1.50	1.50
SK200	0.80	1.30	0.80	1.30	0.80	0.80	SK200 F	0.60	1.04	0.60	1.04	0.60	0.60
SK010	0.38	0.60	0.38	0.60	0.38	0.38	SK010 F	0.38	0.60	0.38	0.60	0.38	0.38
SK250	1.20	1.50	1.40	1.50	1.40	1.40	SK250 F	1.40	1.50	1.40	1.50	1.40	1.40
SK000	0.24	0.41	0.24	0.41	0.24	0.24	SK000 F	0.24	0.41	0.24	0.41	0.24	0.24

www.nord.com

B1000-0713

-4-

-43-

B1000-0713

www.nord.com

8 Appendix

All position numbers are according to drawings and part lists in chapter 7 Parts list/Service kits



SK	M1			M2			M3			M4			M5			M6		
	B3	B6	B8	B6	B8	B3I	B6	B8	B3I	B6	B8	B3I	B6	B8	B3I	B6	B8	B3I
SK9072.1	0,40	0,60	0,95	0,50	0,50	0,50	0,40	0,40	0,40	0,60	0,50	0,50	0,40	0,40	0,40	0,40	0,40	0,40
SK9072.2	0,55	0,90	0,95	1,10	0,75	0,62	0,50	0,50	0,50	0,82	0,87	1,05	0,75	0,65	0,65	0,65	0,65	0,65
SK9272	0,90	1,30	1,45	1,60	1,20	1,20	1,15	1,20	1,20	1,15	1,20	1,15	1,20	1,15	1,15	1,15	1,15	1,15
SK9272.1	1,50	3,50	3,20	3,40	2,60	2,60	1,55	2,80	2,50	3,30	2,40	2,40	2,40	2,40	2,40	2,40	2,40	2,40
SK9272.2	2,30	4,50	4,60	5,30	4,10	4,10	2,75	4,40	4,50	5,85	3,50	3,50	3,50	3,50	3,50	3,50	3,50	3,50
SK9072.1	0,39	0,93	0,79	1,02	0,49	0,62	0,39	0,93	0,79	1,02	0,49	0,62	0,39	0,93	0,79	1,02	0,49	0,62
SK9072.2	0,60	1,17	0,94	1,37	0,65	0,65	0,60	1,17	0,94	1,37	0,65	0,65	0,60	1,17	0,94	1,37	0,65	0,65
SK9372.1	1,00	1,97	1,65	2,14	1,12	1,34	1,00	1,97	1,65	2,14	1,12	1,34	1,00	1,97	1,65	2,14	1,12	1,34
SK9372.2	1,80	3,23	2,71	4,20	2,02	2,45	1,80	3,23	2,71	4,20	2,02	2,45	1,80	3,23	2,71	4,20	2,02	2,45
SK9372.1	2,72	4,63	3,70	5,40	2,93	3,25	2,72	4,63	3,70	5,40	2,93	3,25	2,72	4,63	3,70	5,40	2,93	3,25
SK9016.1	0,70	1,60	1,90	2,40	1,20	1,70	0,70	1,60	1,90	2,40	1,20	1,70	0,70	1,60	1,90	2,40	1,20	1,70
SK9016.2	0,70	1,60	1,90	2,40	1,20	1,70	0,70	1,60	1,90	2,40	1,20	1,70	0,70	1,60	1,90	2,40	1,20	1,70
SK9021.1	1,30	2,60	3,50	4,20	2,00	2,60	1,30	2,60	3,50	4,20	2,00	2,60	1,30	2,60	3,50	4,20	2,00	2,60
SK9021.2	1,70	4,80	5,40	6,70	4,10	5,10	1,90	5,20	6,40	7,30	3,30	5,10	1,90	5,20	6,40	7,30	3,30	5,10
SK9042.1	4,40	8,70	10,00	9,80	6,80	7,50	3,60	9,70	11,40	11,50	6,50	6,20	3,60	9,70	11,40	11,50	6,50	6,20
SK9052.1	6,50	16,00	19,00	21,50	11,00	15,50	7,50	16,50	20,00	23,50	11,50	18,00	7,50	16,50	20,00	23,50	11,50	18,00
SK9052.2	10,00	27,50	32,00	36,00	18,00	24,00	12,00	27,50	33,00	38,50	19,00	26,00	12,00	27,50	33,00	38,50	19,00	26,00
SK9052.3	17,00	52,00	63,00	72,00	33,00	47,00	21,00	54,00	66,00	80,00	38,00	52,00	21,00	54,00	66,00	80,00	38,00	52,00
SK9085.1	29,00	73,00	85,00	102,00	45,00	62,00	36,00	78,00	91,00	107,00	53,00	76,00	36,00	78,00	91,00	107,00	53,00	76,00
SK9085.2	41,00	157,00	170,00	172,00	80,00	90,00	40,00	130,00	154,00	175,00	82,00	91,00	40,00	130,00	154,00	175,00	82,00	91,00
SK9085.3	70,00	187,00	194,00	254,00	109,00	152,00	80,00	187,00	193,00	257,00	113,00	156,00	80,00	187,00	193,00	257,00	113,00	156,00
SK9013.1	1,20	2,00	2,20	3,00	1,40	1,90	1,20	2,30	2,20	3,00	1,40	1,90	1,20	2,30	2,20	3,00	1,40	1,90
SK9017.1	1,20	2,00	2,20	3,00	1,40	1,90	1,20	2,30	2,20	3,00	1,40	1,90	1,20	2,30	2,20	3,00	1,40	1,90
SK9023.1	2,40	3,00	3,60	5,30	2,20	3,10	2,40	3,00	3,60	5,30	2,20	3,10	2,40	3,00	3,60	5,30	2,20	3,10
SK9033.1	3,30	6,60	7,00	7,80	4,30	5,10	3,60	5,70	6,90	8,50	3,60	5,60	3,60	5,70	6,90	8,50	3,60	5,60
SK9043.1	4,60	10,20	10,70	12,80	5,20	6,70	5,70	10,20	14,70	14,70	6,80	9,60	5,70	10,20	14,70	14,70	6,80	9,60
SK9053.1	10,00	17,00	20,00	24,20	11,50	16,50	12,50	18,00	21,50	26,50	13,00	17,00	12,50	18,00	21,50	26,50	13,00	17,00



SK	M1			M2			M3			M4			M5			M6		
	H1	H6	H4	H1	H6	H4	H2	H5	H4	H3	H2	H5	H4	H3	H2	H5	H4	H3
SK10282 A	0,90	1,30	0,90	1,20	0,95	0,95	2,30	2,60	1,90	3,10	1,50	1,50	1,50	1,50	1,50	1,50	1,50	1,50
SK2282 A	1,65	2,40	1,90	2,00	1,80	1,80	4,10	4,90	3,30	5,60	3,30	3,30	3,30	3,30	3,30	3,30	3,30	3,30
SK3282 A	3,15	4,10	3,25	4,10	3,15	3,15	5,90	6,80	4,90	8,30	4,90	4,90	4,90	4,90	4,90	4,90	4,90	4,90
SK4282 A	4,70	6,10	4,75	5,40	4,70	4,70	12,50	12,00	6,70	13,50	8,30	8,30	8,30	8,30	8,30	8,30	8,30	8,30
SK5282 A	7,50	8,80	7,50	8,80	7,20	7,20	1,45	1,60	1,15	1,70	1,10	1,10	1,10	1,10	1,10	1,10	1,10	1,10
SK6382 A	17,00	14,00	12,00	17,50	10,00	14,00	16,50	13,00	9,60	18,00	14,00	14,00	14,00	14,00	14,00	14,00	14,00	14,00
SK7382 A	25,00	21,00	20,00	27,00	16,00	21,00	22,00	20,00	16,00	25,00	23,00	22,00	22,00	22,00	22,00	22,00	22,00	22,00
SK8382 A	37,00	33,00	30,00	41,00	31,00	31,00	34,00	32,00	25,00	36,00	35,00	30,00	30,00	30,00	30,00	30,00	30,00	30,00
SK9382 A	74,00	70,00	65,00	80,00	65,00	65,00	73,00	70,00	45,00	74,00	65,00	60,00	60,00	60,00	60,00	60,00	60,00	60,00
SK10382 A	90	90	40	90	60	82	85	100	73	100	80	80	80	80	80	80	80	80
SK11382 A	165	160	145	195	100	140	160	155	140	210	155	135	135	135	135	135	135	135
SK12382 A							160	155	140	210	155	135	135	135	135	135	135	135

* 38



How to contact Alfa Laval

Contact details for all countries are continually updated on our website.

Please visit www.alfalaval.com to access the information directly.

© Alfa Laval Corporate AB

This document and its contents is owned by Alfa Laval Corporate AB and protected by laws governing intellectual property and thereto related rights. It is the responsibility of the user of this document to comply with all applicable intellectual property laws. Without limiting any rights related to this document, no part of this document may be copied, reproduced or transmitted in any form or by any means (electronic, mechanical, photocopying, recording, or otherwise), or for any purpose, without the expressed permission of Alfa Laval Corporate AB. Alfa Laval Corporate AB will enforce its rights related to this document to the fullest extent of the law, including the seeking of criminal prosecution.