



Alfa Laval CB300 / CBH300

Brazed plate heat exchanger

Alfa Laval CB brazed plate heat exchangers provide efficient heat transfer with a small footprint.

Applications

- HVAC heating and cooling
- Refrigeration
- Oil cooling
- Industrial heating and cooling

Benefits

- Compact
- Easy to install
- Self-cleaning
- Low level of service and maintenance is required
- All units are pressure and leak tested
- Gasket free

Design

The brazing material seals and holds the plates together at the contact points ensuring optimal heat transfer efficiency and pressure resistance. Using advanced design technologies and extensive verification guarantees the highest performance and longest possible service life.

Different pressure ratings are available for different needs.

Based on standard components and a modular concept, each unit is custom-built to meet the specific requirements of each individual installation.



Examples of connections

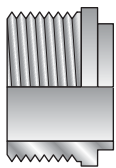

External thread

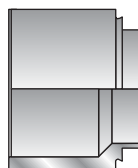

Welding

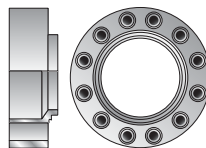

Compact flange

Technical Data

Standard materials

Cover plates	Stainless steel
Connections	Stainless steel
Plates	Stainless steel
Brazing filler	Copper

Dimensions and weight¹

A measure (mm)	11 + (2.62 * n)
A measure (inches)	0.43 + (0.1 * n)
Weight (kg) ²	21 + (1.26 * n)
Weight (lb) ²	46.3 + (2.78 * n)

- n = number of plates
- Excluding connections

Standard data

Volume per channel, litres (gal)	(S1-S2): 0.69 (0.178) (S3-S4): 0.58 (0.150)
Max. particle size, mm (inch)	1.8 (0.071)
Max. flowrate ¹ m ³ /h (gpm)	200 (880)
Flow direction	Parallel
Min. number of plates	10
Max. number of plates	250

- Water at 5 m/s (16.4 ft/s) (connection velocity)

Dimensional drawing

Measurements in mm (inches)

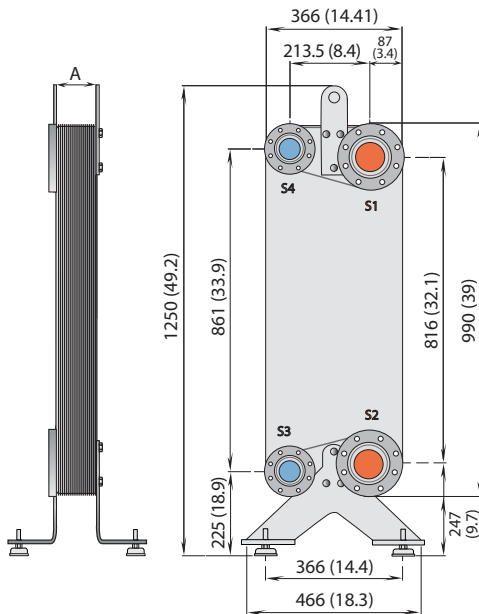

Design pressure and temperature

CB300/CBH300 – PED approval pressure/temperature graph

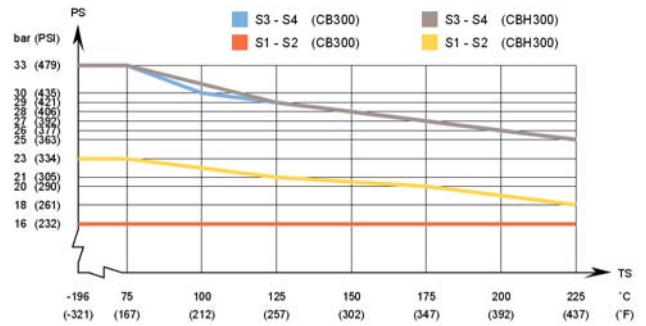

CB300/CBH300 – UL approval pressure/temperature graph

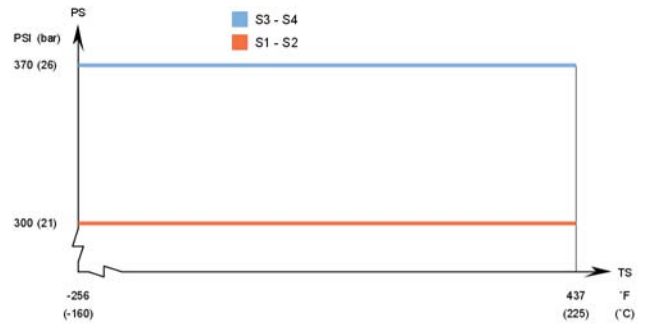

Designed for full vacuum.

Alfa Laval plate heat exchangers are available with a wide range of pressure vessel approvals. Please contact your Alfa Laval representative for more information.

NOTE: Values above are to be used as an indication. For exact values, please use the drawing generated by the Alfa Laval configurator or contact your local Alfa Laval representative.

How to contact Alfa Laval

Contact details for all countries are continually updated on our website. Please visit www.alfalaval.com to access the information direct.