

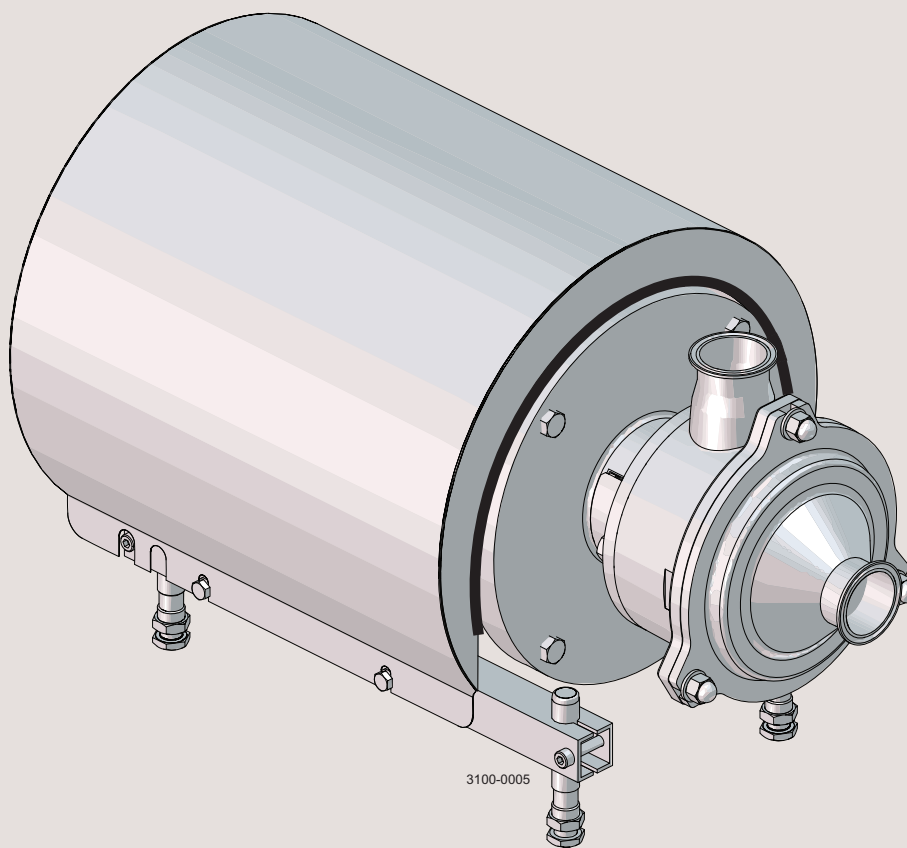

Instruction Manual

MR-166S, -185S, -200S Liquid-Ring Pump



ESE00675-EN5

2017-03

Original manual



www.sk-online.com

The information herein is correct at the time of issue but may be subject to change without prior notice

1. EC Declaration of Conformity	4
2. Safety	5
2.1. Important information	5
2.2. Warning signs	5
2.3. Safety precautions	6
3. Installation	7
3.1. Unpacking/delivery	7
3.2. Installation/Pre-use check - MR-166S	8
3.3. Installation/Pre-use check - MR-185S and MR-200S	10
3.4. Recycling information	11
4. Operation	12
4.1. Operation/Control	12
4.2. Trouble shooting and remedy	13
4.3. Recommended cleaning	14
5. Maintenance	15
5.1. General maintenance	15
5.2. Dismantling of pump - MR-166S	17
5.3. Dismantling of pump - MR-185S and MR-200S	20
5.4. Assambly of pump - MR-166S	23
5.5. Assembly of pump - MR-185S and MR-200S	26
6. Technical data	29
6.1. Technical data	29
6.2. Torque specifications	30
6.3. Weight (kg)	30
6.4. Noise emission	31
7. Parts list and service kits	32
7.1. Drawings MR 166	32
7.2. Drawings MR 185/200	33
7.3. MR - Wet end	34
7.4. MR - Motor dependent parts	36
7.5. MR - Shaft seal	38

1 EC Declaration of Conformity

Revision of Declaration of Conformity 2009-12-29

The Designated Company

Alfa Laval Kolding A/S

Company Name

Albuen 31, DK-6000 Kolding, Denmark

Address

+45 79 32 22 00

Phone No.

hereby declare that

Pump

Designation

MR-166S, MR-185S, MR-200S

Type

From serial number 10.000 to 1.000.000

is in conformity with the following directive with amendments:

- Machinery Directive 2006/42/EC

The person authorised to compile the technical file is the signer of this document

Global Product Quality Manager
Pump, Valves, Fittings and Tank Equipment

Title

Lars Kruse Andersen

Name

Kolding
Place

2016-02-01
Date

Signature



*Unsafe practices and other important information are emphasised in this manual.
Warnings are emphasised by means of special signs. All warnings in this manual are summarised on this page.
Pay special attention to the instructions below so that serious personal injury or damage to the pump are avoided.*

2.1 Important information

Always read the manual before using the pump!

WARNING

Indicates that special procedures must be followed to avoid serious personal injury.

CAUTION

Indicates that special procedures must be followed to avoid damage to the pump.

NOTE

Indicates important information to simplify or clarify procedures.

2.2 Warning signs

General warning:



Dangerous electrical voltage:



Caustic agents:



2 Safety

Unsafe practices and other important information are emphasised in this manual.

Warnings are emphasised by means of special signs. All warnings in this manual are summarised on this page.

Pay special attention to the instructions below so that serious personal injury or damage to the pump are avoided.

2.3 Safety precautions

Installation:

Always read the technical data thoroughly. (See chapter 6 Technical data).

Never stick your fingers or any tool through the adaptor or the drain hole in the pump casing when the pump is running.

Never test the direction of rotation with liquid in the pump.



Always have the pump electrically connected by authorised personnel. (See the motor instruction)

Always disconnect the power supply when servicing the pump.



Operation:

Always read the technical data thoroughly. (See chapter 6 Technical data).

Never touch the pump or the pipelines when pumping hot liquids or when sterilising.

Never run the pump with both the suction side and the pressure side blocked.

Never run the pump when partially installed or not completely assembled.

Necessary precautions must be taken if leakage occurs as this can lead to hazardous situations.



Always handle lye and acid with great care.

Never use the pump for products not mentioned in Alfa Laval pump selection program.

The Alfa Laval pump selection program can be acquired from your local Alfa Laval sales company.



Maintenance:

Always read the technical data thoroughly. (See chapter 6 Technical data).

Never service the pump when it is hot.

Never service the pump if pressurised.



Motors with grease nipples:

Remember lubrication according to the information plate/label on the motor.

Always disconnect the power supply when servicing the pump.

Always use Alfa Laval genuine spare parts.



Transportation:

Transportation of the pump or the pump unit:

Never lift or elevate in any way other than as described in this manual

Always drain the pump head and accessories of any liquid

Always ensure that no leakage of lubricants can occur

Always transport the pump in its upright position

Always ensure that the unit is securely fixed during transportation

Always use the original packaging or similar during transportation

3.1 Unpacking/delivery

Step 1

CAUTION

Alfa Laval cannot be held responsible for incorrect unpacking.
Inspect the pump for visible transport damage.

Check the delivery for:

1. Complete pump, MR-166S, MR-185S or MR-200S.
2. Delivery note.
3. Motor instructions.

Step 2

Clean the inlet and the outlet of all possible packing materials.

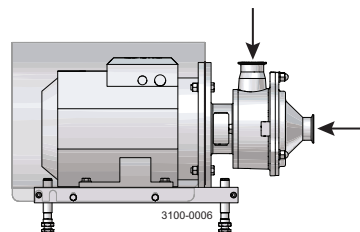

Step 3

Avoid damaging the inlet and the outlet.

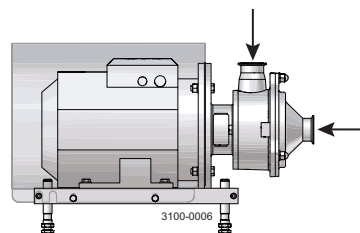

Step 4

Always remove the shroud, if fitted, before lifting the pump.

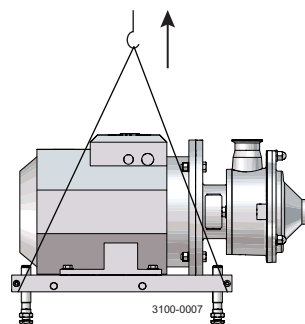

3 Installation

Study the instructions carefully and pay special attention to the warnings!

The direction of rotation of the impeller can be checked by observing the direction of rotation of the motor fan.

- See the indication label on the pump.

3.2 Installation/Pre-use check - MR-166S

Step 1



Always read the technical data carefully.

See chapter 6 Technical data

CAUTION

Alfa Laval cannot be held responsible for incorrect installation.



Never stick your fingers or any tool through the adaptor or the drain hole in the pump casing when the pump is running.

WARNING:

Alfa Laval recommends the installation of a lockable repair breaker. If the repair breaker is to be used as an emergency stop, the colours of the repair breaker must be red and yellow.

CAUTION

The pump does not prevent back flow when intentionally or unintentionally stopped. If back flow can cause any hazardous situations, precautions must be taken e.g. check valve to be installed in the system preventing the problems described above.

NOTE!

In case of shaft seal leakage, the media will drip from the slot in the bottom of the adaptor. In case of shaft seal leakage, Alfa Laval recommends placing a drip tray underneath the slot to collect the leakage.

Step 2

Ensure a clearance of at least 0.5 m around the pump.

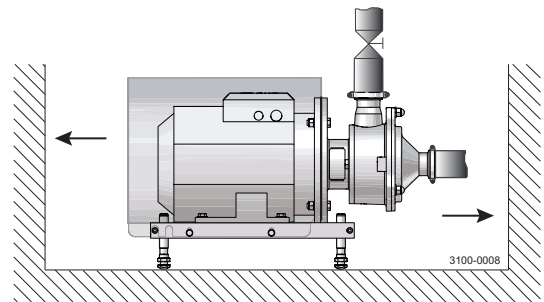

Step 3

Ensure that the flow direction is correct.

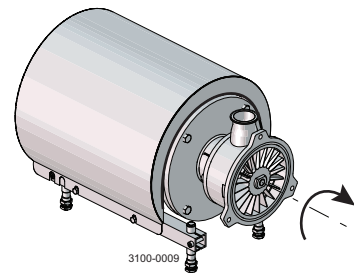

Step 4

1. Ensure that the pipelines are correctly routed.
2. Ensure that connections are tight.

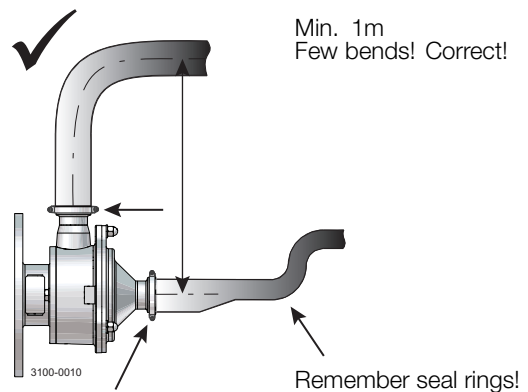

Study the instructions carefully and pay special attention to the warnings!

The direction of rotation of the impeller can be checked by observing the direction of rotation of the motor fan.

- See the indication label on the pump.

Step 5

Avoid stresses to the pump

Pay special attention to:

- Vibrations.
- Thermal expansion of the tubes.
- Excessive welding.
- Overloading of the pipelines.

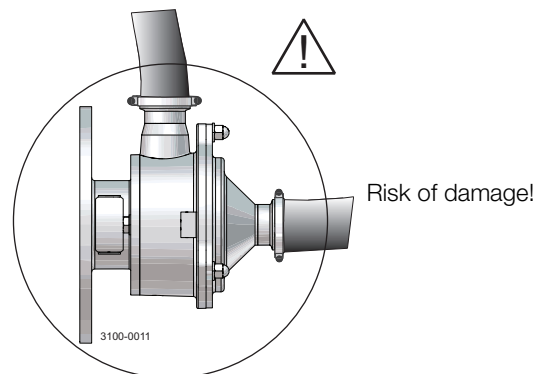

Step 6



Never test the direction of rotation with liquid in the pump.

Pre-use check:

1. Start and stop the motor momentarily.
2. Ensure that the direction of rotation of the motor is **anti-clockwise** as viewed from the back of the motor.

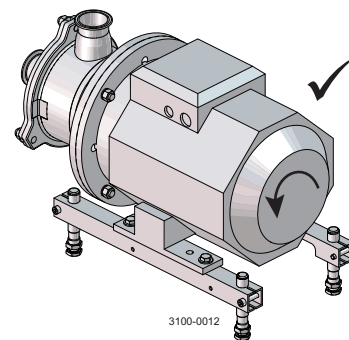

3 Installation

Study the instructions carefully and pay special attention to the warnings!

The direction of rotation of the impeller can be checked by observing the direction of rotation of the motor fan.

- See the indication label on the pump.

3.3 Installation/Pre-use check - MR-185S and MR-200S

Step 1



Always read the technical data carefully.



Never stick your fingers or any tool through the adaptor or the drain hole in the pump casing when the pump is running.



Always have the pump electrically connected by authorised personnel.

CAUTION

Alfa Laval cannot be held responsible for incorrect installation.

Step 2

Ensure a clearance of at least 0.5 m around the pump.

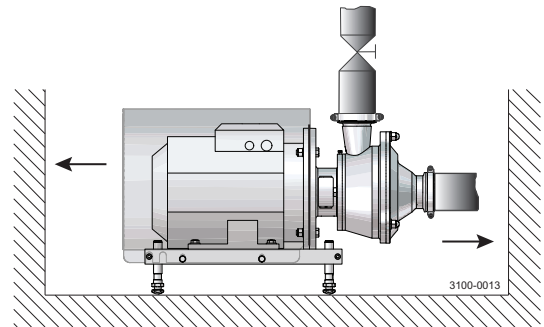

Step 3

Ensure that the flow direction is correct.

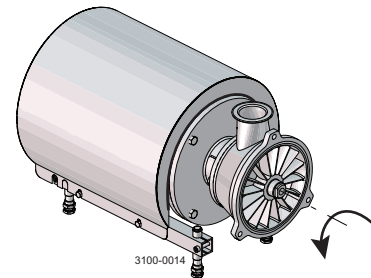

Step 4

1. Ensure that pipelines are routed correctly.
2. Ensure that connections are tight.

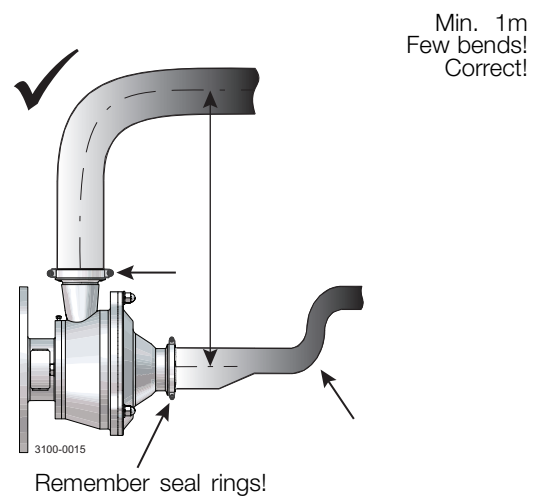

Step 5

Avoid stresses to the pump.

Pay special attention to:

- Vibrations.
- Thermal expansion of the tubes.
- Excessive welding.
- Overloading of the pipelines.

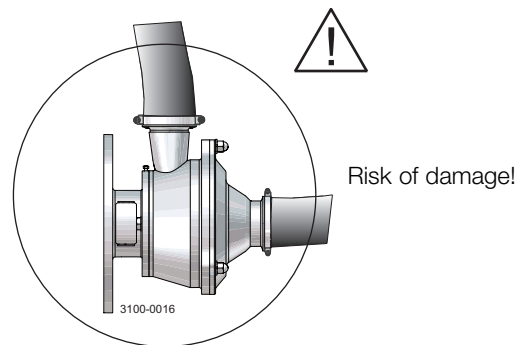

Step 6



Never test the direction of rotation with liquid in the pump.

Pre-use check:

1. Start and stop the motor momentarily.
2. Ensure that the direction of rotation of the motor is **clockwise** as viewed from the back of the motor.

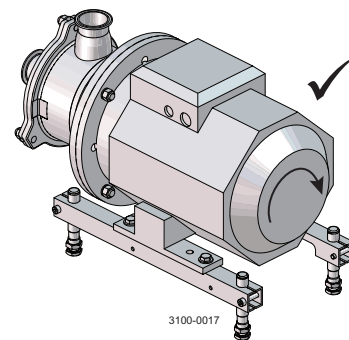

3.4 Recycling information

• Unpacking

- Packing material consists of wood, plastics, cardboard boxes and in some cases metal straps.
- Wood and cardboard boxes can be reused, recycled or used for energy recovery.
- Plastics should be recycled or burnt at a licensed waste incineration plant.
- Metal straps should be sent for material recycling.

• Maintenance

- During maintenance, oil and wear parts in the machine are replaced.
- All metal parts should be sent for material recycling.
- Worn out or defective electronic parts should be sent to a licensed handler for material recycling.
- Oil and all non-metal wear parts must be taken care of in accordance with local regulations.

• Scrapping

- At the end of use, the equipment shall be recycled according to the relevant, local regulations. Besides the equipment itself, any hazardous residues from the process liquid must be considered and dealt with in a proper manner. When in doubt, or in the absence of local regulations, please contact your local Alfa Laval sales company.

4 Operation

Study the instructions carefully and pay special attention to the warnings!
The pump is fitted with a warning label indicating correct throttling.

4.1 Operation/Control

Step 1



Always read the technical data carefully.

CAUTION

Alfa Laval cannot be held responsible for incorrect operation/control.

Step 2



Never touch the pump or the pipelines when pumping hot liquids or when sterilising.

**Danger of burns!
Rotating parts!**



Never stick your fingers or any tool through the adaptor or the drain hole in the pump casing when the pump is running.

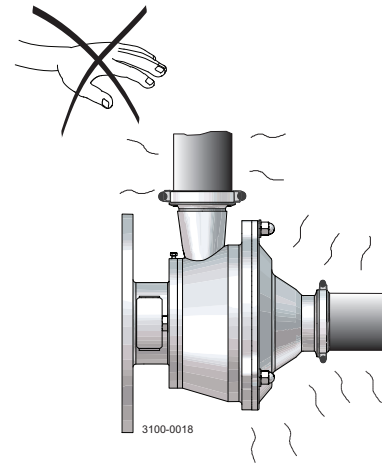

Step 3

Never run the pump with both the suction side and the pressure side blocked.

Danger of explosion!

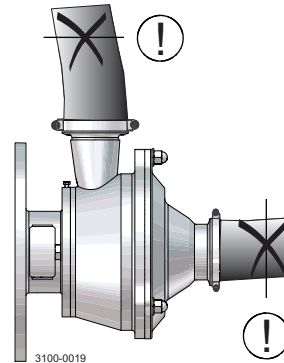

**See the
warning label!**

Step 4

CAUTION

The shaft seal must not run dry.

CAUTION

Never throttle the inlet side.

Control:

Reduce the capacity by means of:

- Throttling the pressure side of the pump.
- Speed control of the motor.

**Do not allow
to run dry**

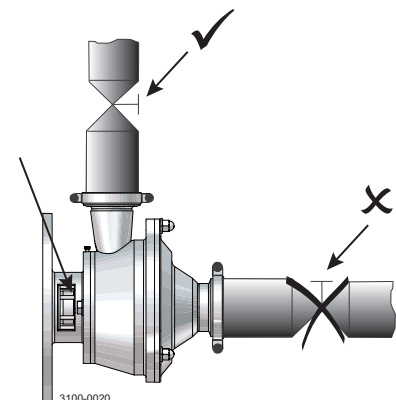

*Pay attention to possible faults.
Study the instructions carefully.*

4.2 Trouble shooting and remedy

Step 1

NOTE

Study the maintenance instructions carefully before replacing worn parts.

Problem	Cause/result	Remedy
Leaking shaft seal	<ul style="list-style-type: none"> - Dry run (see section 3.1) - Incorrect rubber grade - Abrasive particles in the liquid 	<p>Replace: All wearing parts (see section 4.3)</p> <ul style="list-style-type: none"> - Select a different rubber grade - Select stationary and rotating seal ring in silicon carbide/silicon carbide (only MR-185S, -200S)
Leaking seals	Incorrect rubber grade	Select a different rubber grade

4 Operation

The pump is designed for cleaning in place (CIP). CIP = Cleaning In Place. Study the instructions carefully and pay special attention to the warnings! NaOH = Caustic Soda. HNO₃ = Nitric acid.

4.3 Recommended cleaning

Step 1



Always handle lye and acid with great care.

Caustic danger!



Always use rubber gloves!



Always use protective goggles!

Step 2



Never touch the pump or the pipelines when pumping hot liquids or when sterilising.



Danger of burns!

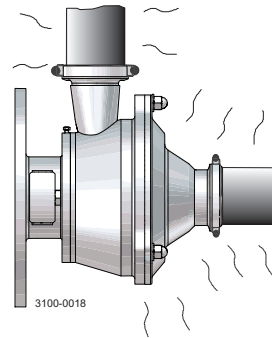

Step 3

Examples of cleaning agents: Use clean water, free from chlorides.

1. 1% by weight NaOH at 70°C (158°F).

1 kg (2.2 lb) NaOH + 100 l (26.4 gal) water = Cleaning agent.

2.2 l (0.6 gal) 33% NaOH + 100 l (26.4 gal) water = Cleaning agent.

2. 0.5% by weight HNO₃ at 70°C (158°F).

0.7 l (0.2 gal) 53% HNO₃ + 100 l (26.4 gal) water = Cleaning agent.

1. Avoid excessive concentration of the cleaning agent
⇒ Dose gradually!
2. Adjust the cleaning flow to the process.
Sterilisation of milk/viscous liquids
⇒ Increase the cleaning flow!

Step 4



Always rinse well with clean water after using a cleaning agent.

Always rinse!



Clean water Cleaning agent

NOTE

The cleaning agents must be stored/disposed of in accordance with current regulations/directives.

Maintain the pump carefully. Study the instructions carefully and pay special attention to the warnings! Always keep spare shaft seals and rubber seals in stock. See separate motor instructions.

5.1 General maintenance

Step 1



Always read the technical data carefully.



Always disconnect the power supply when servicing the pump.

Step 2



Never service the pump when it is hot.

NOTE

All scrap must be stored/discharged in accordance with current rules/directives.



Danger of burns!

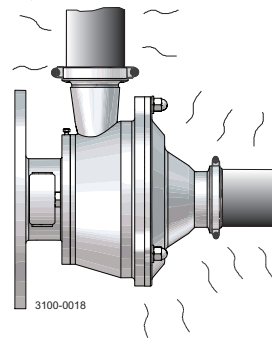

Step 3



The pump and the pipelines must **never** be pressurised when the pump is serviced.

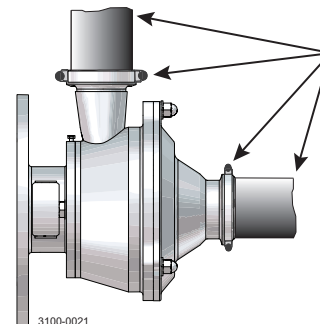

Atmospheric pressure required!

Step 4

CAUTION

Always ensure that the impeller rotates smoothly after service.

CAUTION

Fit the electrical connections correctly if they have been removed from the motor during service.

Pay special attention to the warnings!

1. Rotate impeller (11) through the inlet.
2. Ensure that the impeller does not come into contact with pump casing (9) or casing cover (10).
3. Adjust the impeller position if necessary (see section 4.4 for MR-166S and section 4.5 for MR-185S and MR-200S).

Step 5

Ordering spare parts

Contact your local Alfa Laval sales company.

Recommended spare parts:

Order service kits from the service kits list (see chapter 7 Parts list and service kits.)

5 Maintenance

Maintain the pump carefully. Study the instructions carefully and pay special attention to the warnings! Always keep spare shaft seals and rubber seals in stock. See separate motor instructions.

	Shaft seals	Rubber seals	Motor bearings
Preventive maintenance	Replace after 12 months (one-shift) Complete shaft seal	Replace when replacing the shaft seal	
Maintenance after leakage (leakage normally starts slowly)	Replace at the end of the day: Complete shaft seal	Replace when replacing the shaft seal	
Planned maintenance	<ul style="list-style-type: none"> - Regular inspection for leakage and smooth operation - Keep a record of the pump - Use the statistics for inspection planning Replace after leakage: Complete shaft seal	Replace when replacing the shaft seal	Yearly inspection is recomm. <ul style="list-style-type: none"> - Replace complete bearing if worn - Ensure that the bearing is axially locked (See motor instructions)
Lubrication	Before fitting Lubricate the O-rings with silicone grease or silicone oil (not the sealing surfaces)	Before fitting Silicone grease or silicone oil	None The bearings are permanently lubricated

Study the instructions carefully. The items refer to the parts list and service kits section. Handle scrap correctly.

5.2 Dismantling of pump - MR-166S

Step 1

Loosen screws (43) and remove shroud (5).

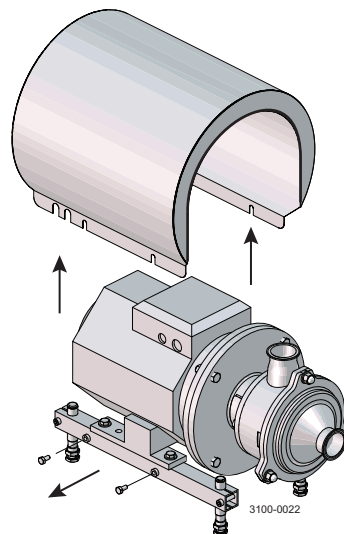

Step 2

Remove covers (2a)

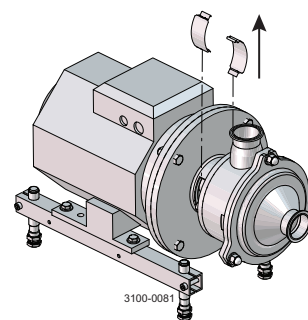

Step 3

Remove cap nuts (14), washers (15a) and casing cover (10).

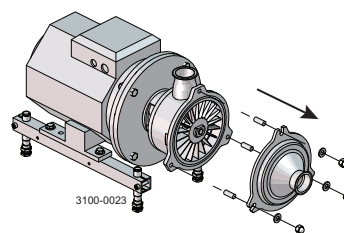

Step 4

Remove O-ring (8) from pump casing (9).

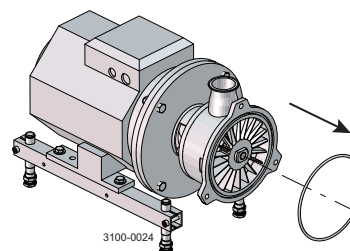

5 Maintenance

Study the instructions carefully. The items refer to the parts list and service kits section. Handle scrap correctly.

Step 5

1. Remove impeller nut clockwise (13),
(counterhold stub shaft (3)).
2. Remove impeller (11) from the stub shaft.

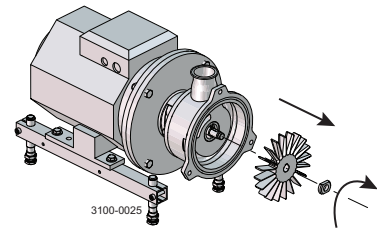

Step 6

Remove key (12) from stub shaft (3) using a pair of pliers.

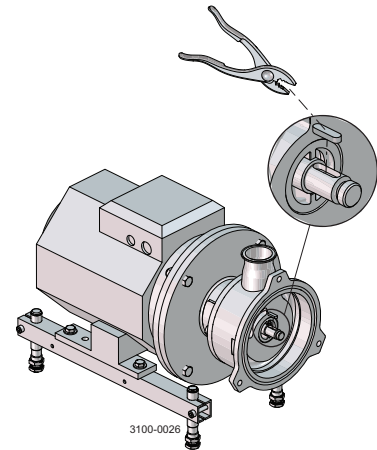

Step 7

Turn stationary seal ring (29) anti-clockwise and remove it from pump casing (9) (use the tool supplied).

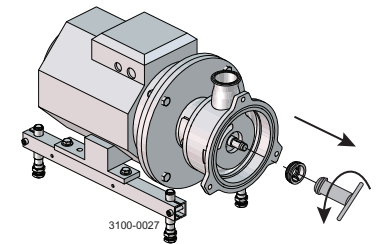

Step 8

Remove O-ring (30) from stationary seal ring (29).

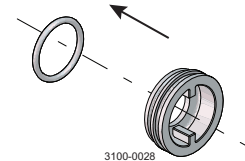

Step 9

Remove rotating seal ring (28), O-ring (27), washer (26), spacer ring (25) and spring (24) from stub shaft (3).

NOTE!

If necessary, insert a screwdriver through the hole in the pump casing (9) and push the seal parts out.

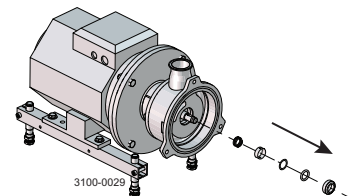

Step 10

1. Remove screws (45) and washers (46).
2. Remove bracket (2) together with pump casing (9).

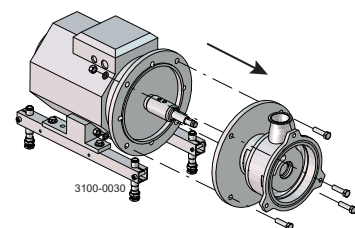

5 Maintenance

Study the instructions carefully. The items refer to the parts list and service kits section. Handle scrap correctly.

Step 11

1. Remove screws (40).
2. Remove pump casing (9) from bracket (2).

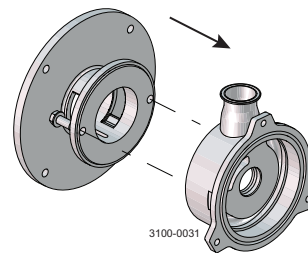

Step 12

- Remove thrower (21) from stub shaft (3).

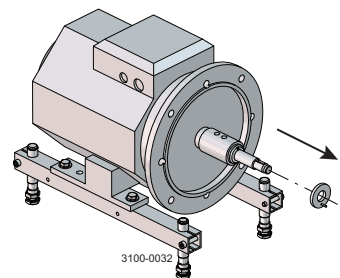

Step 13

1. Loosen screws (4)
2. Remove stub shaft (3).

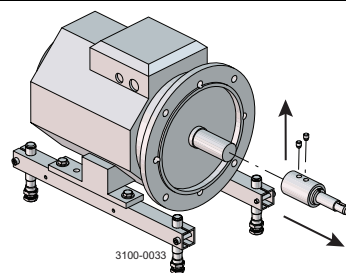

5 Maintenance

Study the instructions carefully. The items refer to the parts list and service kits section. Handle scrap correctly.

5.3 Dismantling of pump - MR-185S and MR-200S

Step 1

Remove screws (34), shroud (31) and distance sleeve (42).

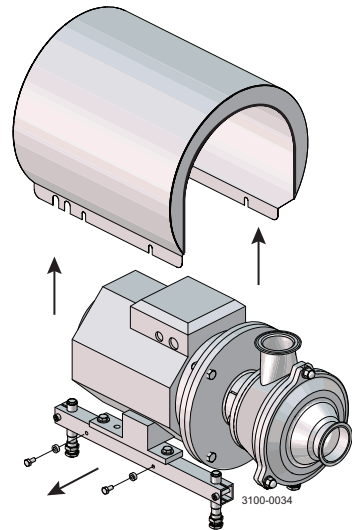

Step 2

Remove covers (2a)

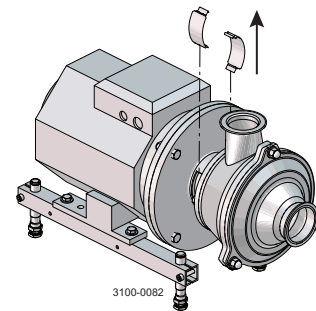

Step 3

Remove cap nuts (14), washers (15a) and casing cover (10).

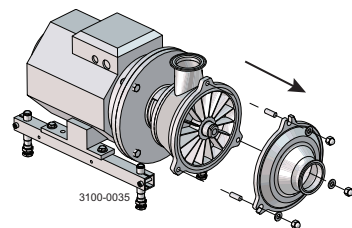

Step 4

Remove O-ring (8) from pump casing (9).

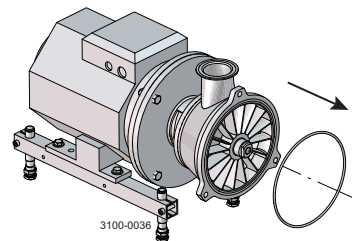

Step 5

1. Remove impeller nut (13) anti-clockwise, (counterhold stub shaft (3)).
2. Remove impeller (11) from the stub shaft.

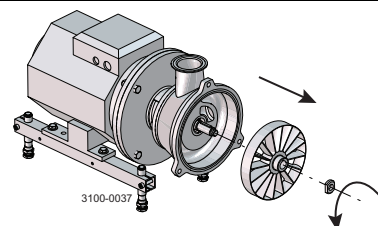

Study the instructions carefully. The items refer to the parts list and service kits section. Handle scrap correctly.

Step 6

Remove key (12) from stub shaft (3) using a pair of pliers.

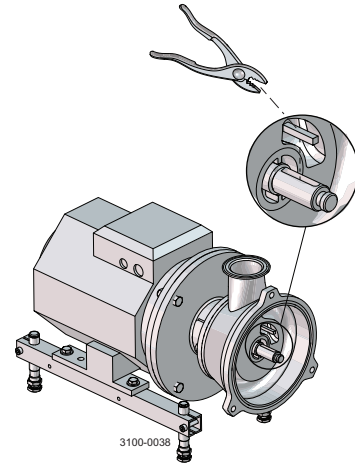

Step 7

Turn stationary seal ring (28) clockwise and remove it from pump casing (9) (use the tool supplied).

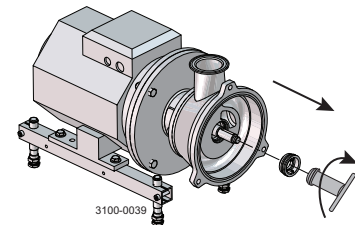

Step 8

Remove O-ring (30) from stationary seal ring (29).

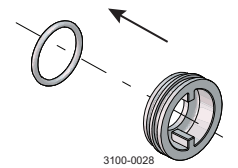

Step 9

Remove rotating seal ring (27), spring (25) and O-ring (26) from stub shaft (3).

NOTE!

If necessary, place a screwdriver through the hole in pump casing (9) and push the seal parts out.

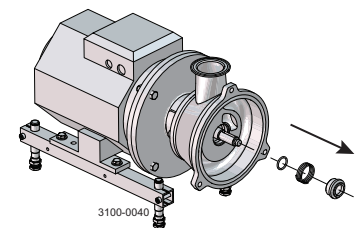

Step 10

1. Remove screws (6) and washers (7).
2. Remove adaptor (2) together with pump casing (9).

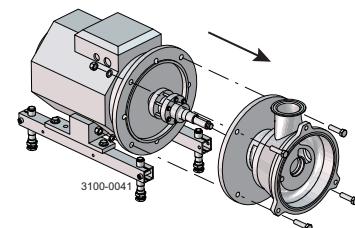

5 Maintenance

Study the instructions carefully. The items refer to the parts list and service kits section. Handle scrap correctly.

Step 11

1. Remove screws (16) and washers (17).
2. Remove pump casing (9) from adaptor (2).

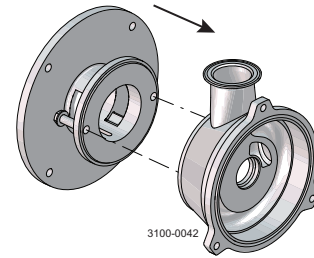

Step 12

1. Remove thrower (24) from stub shaft (3).

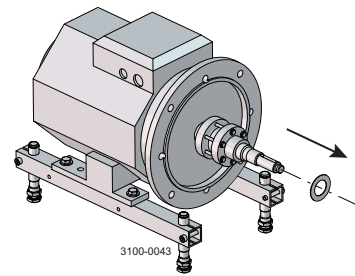

Step 13

1. Loosen screws (5).
2. Remove stub shaft (3) together with compression rings (4a+b).

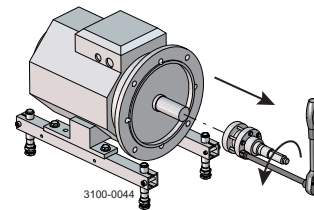

Step 14

1. Remove screws (5), washer (5a) and compression rings (4a+b) from stub shaft (3).

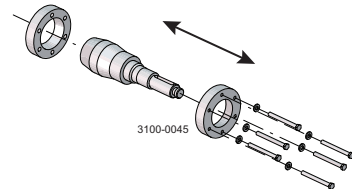

Study the instructions carefully. The items refer to the parts list and service kits section. Lubricate the rubber seals before fitting them.

5.4 Assembly of pump - MR-166S

Step 1

1. Fit stub shaft (3) on the motor shaft.
2. Check the clearance between the end of the stub shaft and the motor flange (10-20 mm)

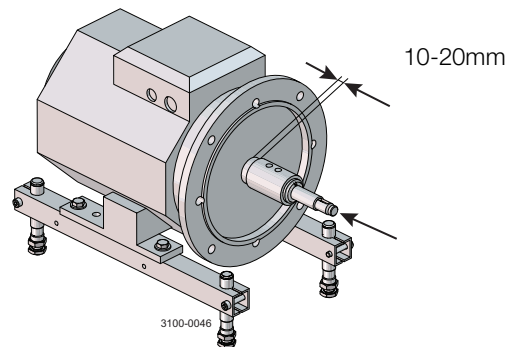

Step 2

1. Tighten screws (4) lightly and evenly.
2. Ensure that the stub shaft (3) can be moved on the motor shaft.

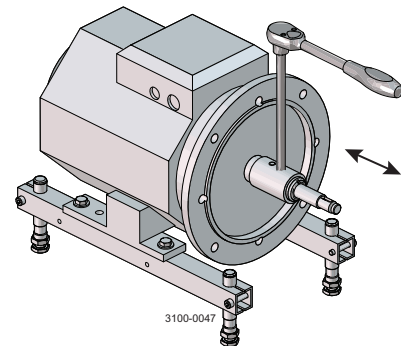

Step 3

1. Fit pump casing (9) on bracket (2).
2. Fit washers (41) and screws (40).
3. Tighten the screws.

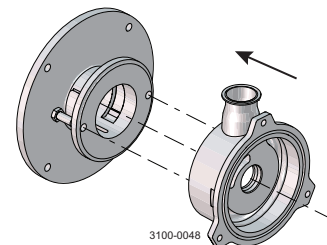

Step 4

1. Fit bracket (2) on the motor.
2. Fit washers (46) and screws (45).
3. Tighten the screws.

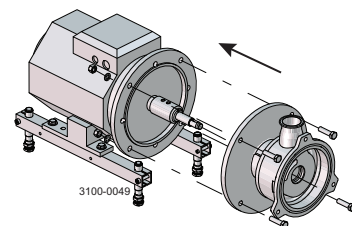

Step 5

1. Fit impeller (11) on stub shaft (3).
2. Fit impeller nut anti-clockwise (13) on the shaft and tighten lightly.

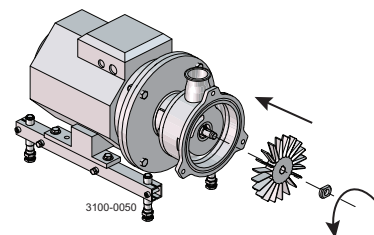

5 Maintenance

Study the instructions carefully. The items refer to the parts list and service kits section. Lubricate the rubber seals before fitting them.

Step 6

Ensure that the clearance between impeller (11) and pump casing (9) is 0.2-0.3 mm (tap gently with a plastic hammer).

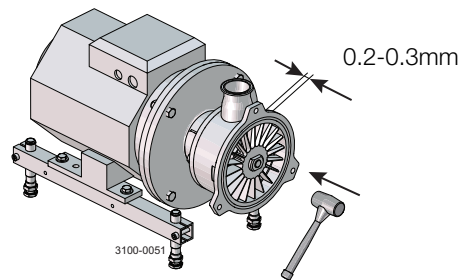

Step 7

Remove impeller (11), pump casing (9) and bracket (2) without moving stub shaft (3) on the motor shaft.

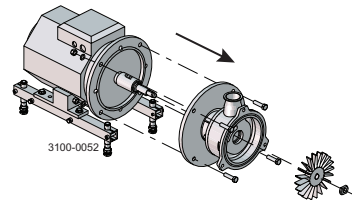

Step 8

Torque tighten screws (4) evenly to 15 Nm

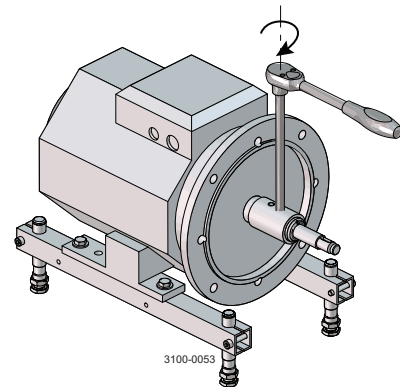

Step 9

1. Fit thrower (21) on stub shaft (3).
2. Fit bracket (2) together with pump casing (9) on the motor.
3. Fit washers (46) and screws (45).

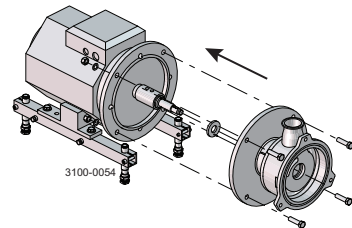

Step 10

CAUTION!

Ensure that the notch in the seal ring is opposite the driving pin on thrower (21).

1. Fit spring (24), spacer ring (25) and washer (26) on the stub shaft.
2. Lubricate O-ring (27) and fit it on the stub shaft.
3. Fit rotating seal ring (28) on the stub shaft.

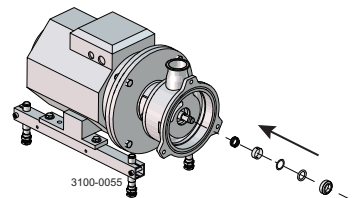

Step 11

1. Fit O-ring (30) on stationary seal ring (29).
2. Fit the seal ring in pump casing (9), turn it clockwise and tighten (use the tool supplied).

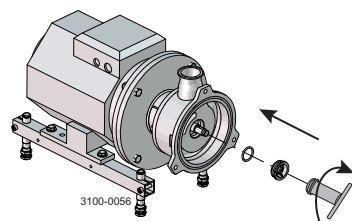

Study the instructions carefully. The items refer to the parts list and service kits section. Lubricate the rubber seals before fitting them.

Step 12

1. Place key (12) in the groove of stub shaft (3).
2. Fit impeller (11) on the shaft.
3. Fit and tighten impeller nut (13) anti-clockwise on the shaft.
4. Check that the clearance between the impeller and the pump casing (9) is 0.2 - 0.3 mm (adjust if necessary).

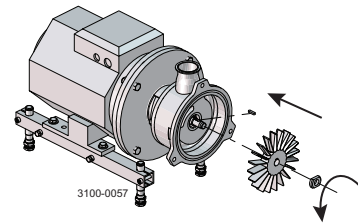

Step 13

1. Fit O-ring (8) in pump casing (9).
2. Fit casing cover (10).
3. Fit washers (15a) and cap nuts (14).
4. Tighten the cap nuts firmly.
5. Ensure that impeller (11) rotates smoothly (see section 2.3).

Note! Pay special attention to warnings.

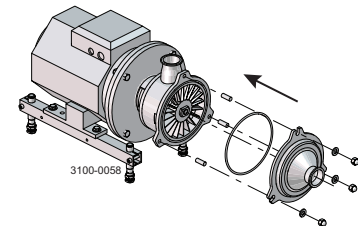

Step 14

1. Fit shroud (5).
2. Fit distance sleeve (44) and screws (43).

CAUTION! Ensure that the notch in the seal ring is opposite the driving pin on thrower (21).

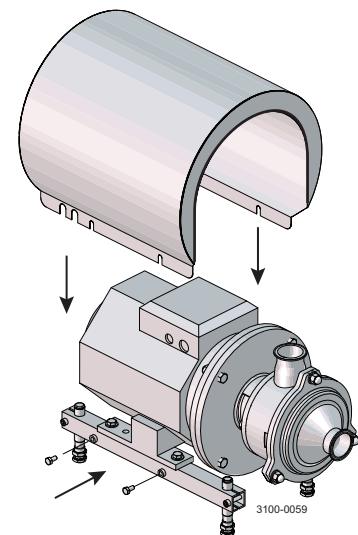

Step 15

Fit covers (2a)

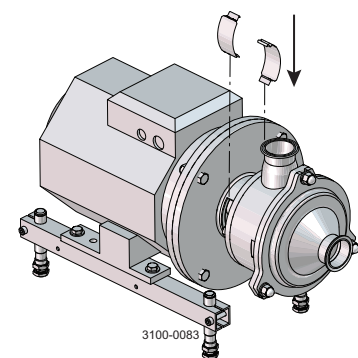

5 Maintenance

Study the instructions carefully. The items refer to the parts list and service kits section. Lubricate the rubber seals before fitting them.

5.5 Assembly of pump - MR-185S and MR-200S

Step 1

Fit compression rings (4a+b), screws (5) and washer (5a) correctly on stub shaft (3).

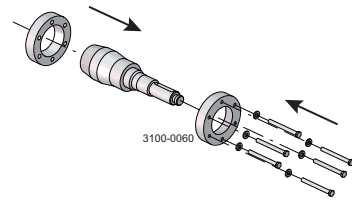

Step 2

1. Fit stub shaft (3) on the motor shaft.
2. Check the clearance between the end of the stub shaft and the motor flange (10-20 mm)

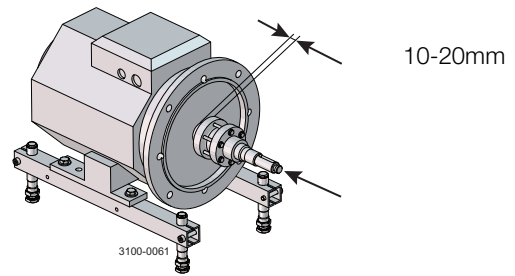

Step 3

1. Tighten screws (5) lightly and evenly.
2. Ensure that stub shaft (3) can be moved on the motor shaft.

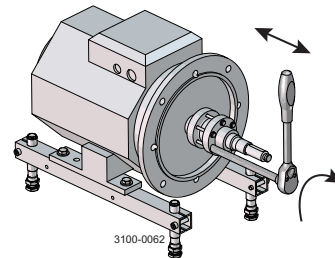

Step 4

1. Fit pump casing (9) on adaptor (2).
2. Fit washers (17) and screws (16).
3. Tighten the screws.

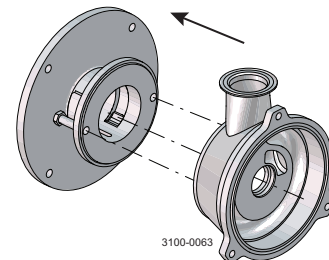

Step 5

1. Fit adaptor (2) on the motor.
2. Fit washers (7) and screws (6).
3. Tighten the screws.

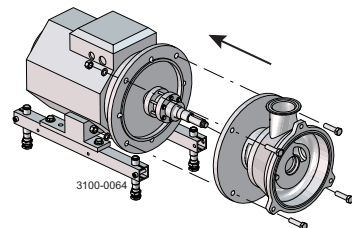

Step 6

1. Fit impeller (11) on stub shaft (3).
2. Fit impeller nut (13) clockwise on the shaft and tighten lightly.

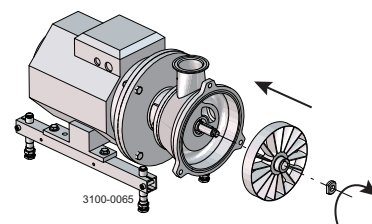

Study the instructions carefully. The items refer to the parts list and service kits section. Lubricate the rubber seals before fitting them.

Step 7

Ensure that the clearance between impeller (11) and pump casing (9) is 0.15-0.20 mm (tap gently with a plastic hammer).

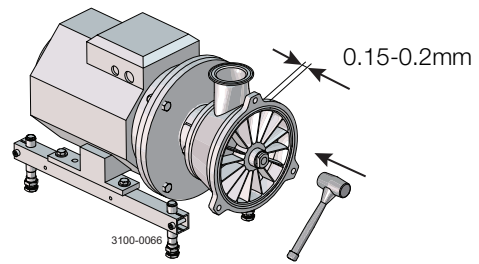

Step 8

Remove impeller (11), pump casing (9) and adaptor (2) without moving stub shaft (3) on the motor shaft.

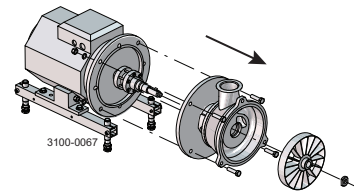

Step 9

Torque tighten screws (5) evenly to 15 Nm (counterhold stub shaft (3)).

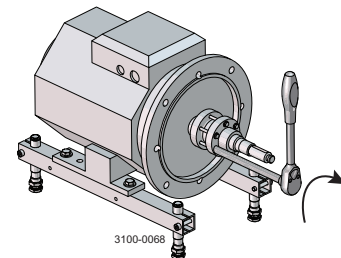

Step 10

1. Fit thrower (24) on stub shaft (3).
2. Fit adaptor (2) together with pump casing (9) on the motor.
3. Fit washers (7) and screws (6).

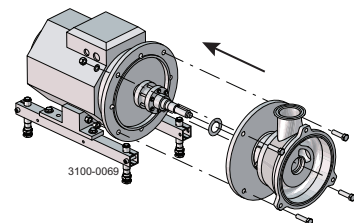

Step 11

1. Lubricate O-ring (26) and push it on stub shaft (3) and position it correctly.
2. Place spring (25) on rotating seal ring (27).
3. Push the seal ring over the O-ring as far as possible against the shoulder.

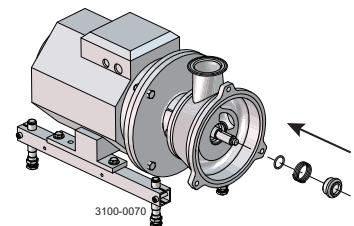

Step 12

1. Fit O-ring (29) on stationary seal ring (28).
2. Fit the seal ring in pump casing (9), turn anti-clockwise and tighten (use the tool supplied).

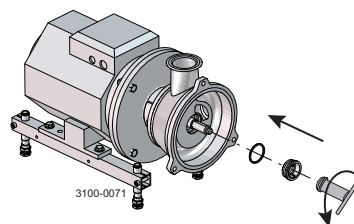

5 Maintenance

Study the instructions carefully. The items refer to the parts list and service kits section. Lubricate the rubber seals before fitting them.

Step 13

1. Place key (12) in the groove of stub shaft (3).
2. Fit impeller (11) and impeller nut (13) on the shaft.
3. Tighten the nut clockwise.

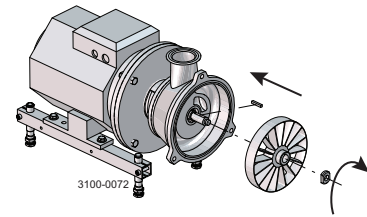

Step 14

1. Fit O-ring (8) in pump casing (9).
2. Fit casing cover (10).
3. Fit washers (15a) and cap nuts (14).

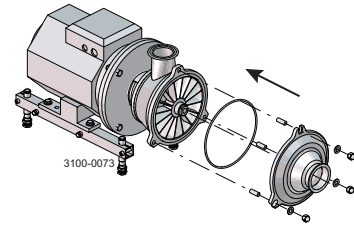

Step 15

1. Fit shroud (31).
2. Fit distance sleeve (42), washers (33) and screws (34).

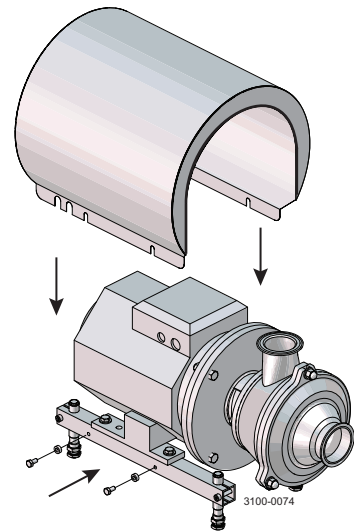

Step 16

Fit covers (2a)

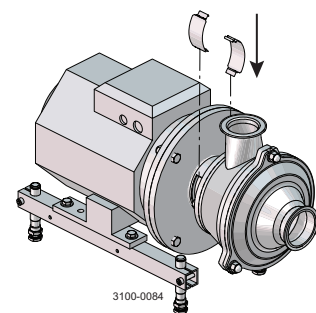

*It is important to observe the technical data during installation, operation and maintenance.
Inform personnel about the technical data.*

6.1 Technical data

MR is a liquid-ring pump specially designed for pumping liquids containing air or gas. The pump is for use in the food, chemical, pharmaceutical and similar industries. The pump is mainly used for CIP-return application. This instruction manual is part of the delivery. Study the instructions carefully. The pump is available in the following sizes, MR-166S, MR-185S and MR-200S.

Data	
Max. inlet pressure	400 kPa (4 bar)
Temperature range	-10°C to +140°C (EPDM)
Max. speed	1800 rpm
Materials	
Product wetted steel parts	AISI 316L
Other steel parts	Stainless steel
Product wetted seals	EPDM (standard)
Alternative seals	Nitrile (NBR) and flourinated rubber (FPM)
Finish	Standard blasted
Shaft seal	
Seal type	Mechanical single seal
Material, stationary seal ring	Acid resistant steel, duplex grade (standard) or Acid resistant steel, duplex grade with sealing surface of silicon carbide*
Material, rotating seal ring	Carbon (standard) or silicon carbide*
Material, O-rings	EPDM (standard)
Alternative material, O-rings	Nitrile (NBR) and flourinated rubber (FPM)
Motor	
Standard foot-flanged motor according to IEC metric standard	
4 pol = 1500/1800 rpm. at 50/60 Hz	
IP55 (with drain holes with labyrinth plug), insulation class F	
IEC motors (kW)	
Motor sizes, 50 Hz	2.2 Frame size 100 (MR-166S)
Motor sizes, 60 Hz	2.5 Frame size 100 (MR-166S)
Motor sizes, 50 Hz	5.5 Frame size 132 (MR-185S)
	7.5 Frame size 132 (MR-200S)
	11 Frame size 132 (MR-200S)
Motor sizes, 60 Hz	6.3 Frame size 132 (MR-185S)
	8.6 Frame size 132 (MR-200S)
	12.5 Frame size 132 (MR-200S)
NEMA motors (Hp)	
Motor sizes, 60 Hz	3.35 (MR-166S)
Motor sizes, 60 Hz	8.44 (MR-185S)
Motor sizes, 60 Hz	11.5 (MR-200S), 16.75 (MR-200S)
* Only MR-185S and MR-200S.	

6 Technical data

*It is important to observe the technical data during installation, operation and maintenance.
Inform personnel about the technical data.*

6.2 Torque specifications

The table below specifies the tightening torques for the screws, bolts and nuts in this pump.

Always use the torques specified below if no other values are stated. This can be a matter of personal safety.

Size	Tightening torque	
	Nm	lbf-ft
M8	20	15
M10	40	30
M12	67	49
M14	110	81

6.3 Weight (kg)

Pump Type: MR

Size	Motor					
	90 2.2kW	132 5.5kW	132 7.5kW	160 11kW	160 15kW	160 18.5kW
166S	74					
185S		104				
200S			119	160		
300					188	217

Weight can vary depending of configuration. Weight is only to be seen as a reference value during handling, transporting and packaging.

*It is important to observe the technical data during installation, operation and maintenance.
Inform personnel about the technical data.*

6.4 Noise emission

Pump Type	Sound pressure level (dBA)
LKH-5	60
LKH-10	69
LKH-15	72
LKH-20	70
LKH-25	74
LKH-35	71
LKH-40	75
LKH-45	70
LKH-50	75
LKH-60	77
LKH-70	88
LKH-75	79
LKH-85	86
LKH-90	75
LKH-112	70
LKH-113	69
LKH-114	68
LKH-122	75
LKH-123	77
LKH-124	80
SolidC-1	68
SolidC-2	72
SolidC-3	73
SolidC-4	72
MR-166	76
MR-185	82
MR-200	81
MR-300	82
GM	54
FM-OS	61

The above LKH noise levels are the same for LKHPF, LKHI, LKH UltraPure, LKH Evap, LKH Hex.
The above SolidC noise levels are the same for SolidC UltraPure.

The noise measurements have been carried out using the original motor and shroud, at the approximate Best Efficiency Point (BEP) with water at ambient temperature and at 50 Hz.

Very often, the noise level generated by the flow through the process system (e.g. valves, pipes, tanks etc.) is much higher than what generated by the pump itself. Therefore, it is important to consider the noise level from the total system and take the necessary precautions with regards to personal safety if required.

7 Parts list and service kits

The drawings show MR-166S, -185S and -200S and include all items.
The items refer to the parts lists in the following sections.

7.1 Drawings MR 166

For further information, see parts list section 6.2.

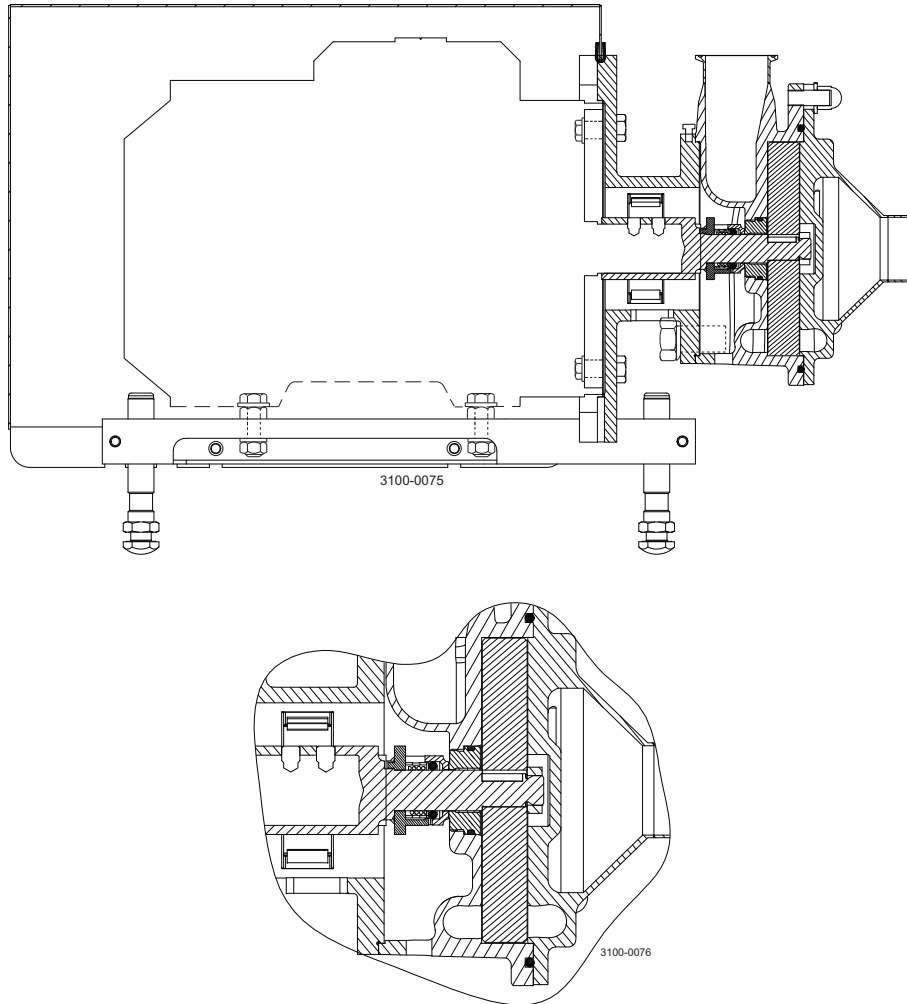

7 Parts list and service kits

The drawings show MR-166S, -185S and -200S and include all items.
The items refer to the parts lists in the following sections.

7.2 Drawings MR 185/200

For further information, see parts list section 6.3

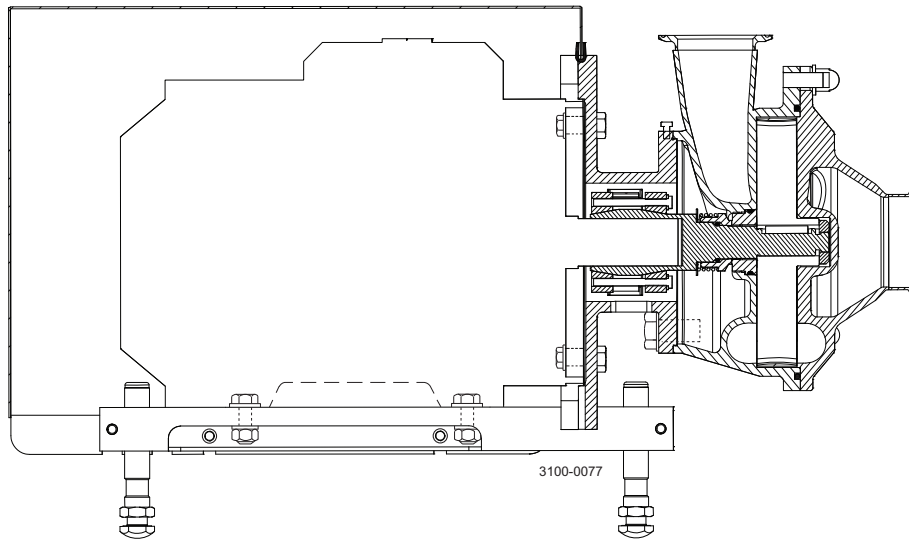

Shaft seal

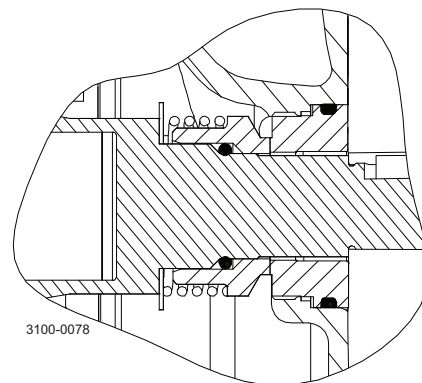

7 Parts list and service kits

The drawing shows the MR-166S, sanitary version. The items refer to the parts lists in the following sections.

7.3 MR - Wet end

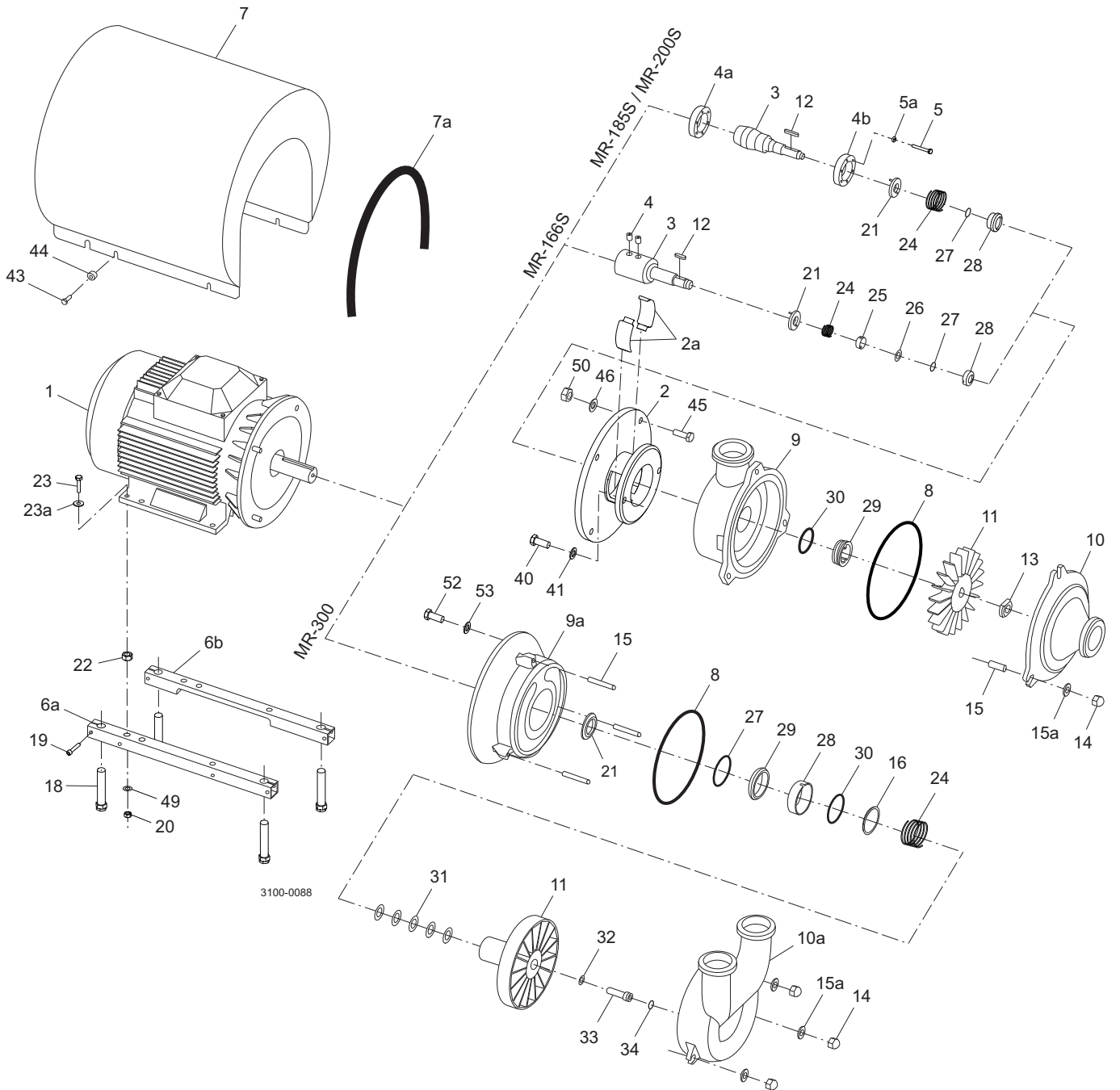

7 Parts list and service kits

The drawing shows the MR-166S, sanitary version. The items refer to the parts lists in the following sections.

Parts list

Pos.	Qty	Denomination
		ISO male
		SMS
		DIN
		ISO clamp
		BS
8 □	1	O-ring, EPDM (Standard)
9	1	Pump casing
10	1	Casing cover
10a	1	Casing cover
11	1	Impeller
13		Impeller screw
14	3	Cap nut
15	3	Stud bolt
15a	3	Washer
21	1	Thrower
31	1-2	Shims, 0.1 mm
32	1	Washer for impeller screw
33	1	Impeller nut
34 □	1	O-ring, EPDM (Standard)

7 Parts list and service kits

The drawing shows the MR-185S -200S, sanitary version. The items refer to the parts lists in the following sections

7.4 MR - Motor dependent parts

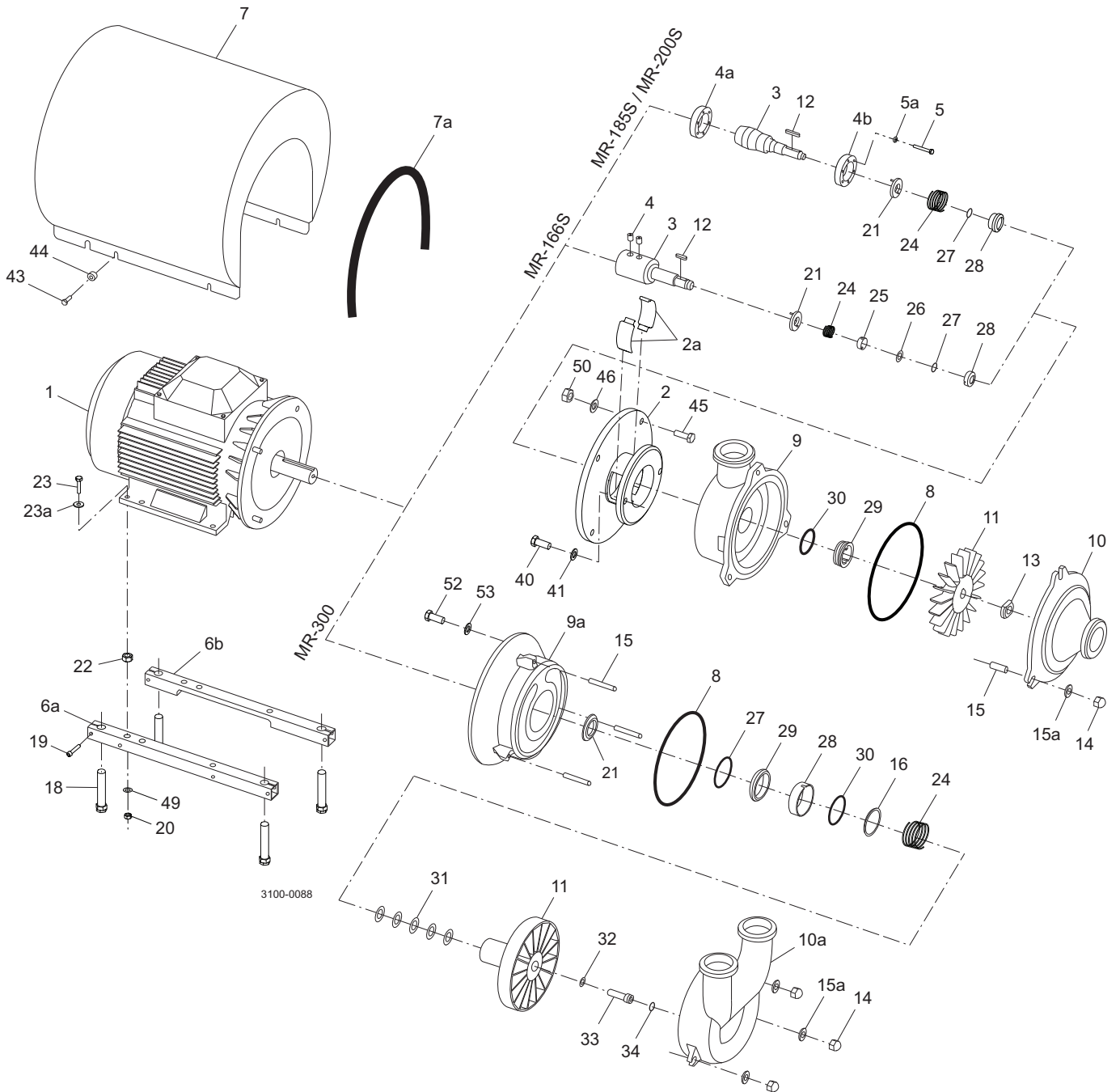

7 Parts list and service kits

The drawing shows the MR-185S -200S, sanitary version. The items refer to the parts lists in the following sections

Parts list

Pos.	Qty	Denomination
1	1	Motor ABB
2	1	Bracket
2a	2	Bracket cover
3	1	Shaft
4	2	Screw
4a	1	Compression ring
4b	1	Compression ring
5	6	Screw
5a	6	Washer
6a	1	Support bar, right
6b	1	Support bar, left
7	1	Shroud complete
7a	1	Edge list
12	4	Key
18	4	Legs
19	4	Screw
20	4	Nut
22	4	Nut
23	4	Screw
23a	4	Washer
40	2	Screw
41	2	Spring washer
43	4	Screw
44	4	Distance sleeve
45	4	Screw
46	4	Washer
49	4	Spring washer
50	4	Nut
52	4	Screw
53	4	Spring washer

7 Parts list and service kits

The drawing shows the MR-185S -200S, sanitary version. The items refer to the parts lists in the following sections

Parts list

Pos.	Qty	Denomination
	1	Spanner for stationary seal ring
	1	Key for hexagonal socket
	1	Impeller tool
	1	Shaft seal tool
□		Shaft seal
□		Shaft seal
□		Shaft seal
24	1	Spring
25	1	Space ring
26	1	Washer
27	1	O-ring
28	1	Rotating seal ring
29	1	Stationary seal ring
30	1	O-ring

Service kits

Denomination	MR-166S	MR-185S/ 200S	MR-300
□ Service kit, EPDM	9611921078	9611921081	9611921084
□ Service kit, NBR	9611921079	9611921082	9611921085
□ Service kit, FPM	9611921080	9611921083	9611921086

Parts marked with □ are included in the service kits.

Recommended spare parts: Service kits.

(900692/2)

How to contact Alfa Laval

Contact details for all countries are continually updated on our website.

Please visit www.alfalaval.com to access the information directly.

© Alfa Laval Corporate AB

This document and its contents is owned by Alfa Laval Corporate AB and protected by laws governing intellectual property and thereto related rights. It is the responsibility of the user of this document to comply with all applicable intellectual property laws. Without limiting any rights related to this document, no part of this document may be copied, reproduced or transmitted in any form or by any means (electronic, mechanical, photocopying, recording, or otherwise), or for any purpose, without the expressed permission of Alfa Laval Corporate AB. Alfa Laval Corporate AB will enforce its rights related to this document to the fullest extent of the law, including the seeking of criminal prosecution.