

INSTALLATION, SERVICE AND MAINTENANCE INSTRUCTIONS

CONTROL VALVE

INNOVA G



www.sks-online.com

Original Manual
10.247.30.03EN
(0) 2019/09

EC Declaration of Conformity

We,

INOXPA, S.A.U.

Telers, 60
17820 – Banyoles (Girona)

Hereby declare under our sole responsibility that the machine

Control Valve

Designation

INNOVA

Type

INNOVA G

From serial number **IXXXXXX** to **IXXXXXX** ⁽¹⁾ / **XXXXXXXXXXIIN** to **XXXXXXXXXXIIN** ⁽¹⁾

Fulfills all the relevant provisions of the following directive:

Machinery Directive 2006/42/CE

Pressure Equipment Directive 2014/68/EU

In compliance with **Regulation EC 1935/2004** relating to materials and articles intended to come into contact with food.

The technical file has been prepared by the signer of this document in INOXPA S.A.U.

A handwritten signature in black ink, appearing to be "David Rejero Brunet".

David Rejero Brunet
Technical Office Manager

Banyoles, 30th September, 2019

1. Table of Contents

1. Table of Contents	
2. Generalities	
2.1. Instructions manual	4
2.2. Compliance with the instructions	4
2.3. Warranty.....	4
3. Safety	
3.1. Warning symbols.....	5
3.2. General safety instructions	5
4. General Information	
4.1. Description	6
4.2. Application.....	6
5. Installation	
5.1. Reception of the valve	7
5.2. Transport and storage.....	7
5.3. Identification of the valve	7
5.4. Location.....	9
5.5. Direction of flow.....	9
5.6. General installation	9
5.7. Checking and review.....	10
5.8. Welding	10
5.9. Valve configuration with actuator	10
5.10. Actuator air connection	11
6. Start-up	
7. Operating problems	
8. Maintenance	
8.1. General considerations	14
8.2. Maintenance.....	14
8.3. Cleaning	15
8.4. Assembly and disassembly of the INNOVA G valve	17
8.5. Replacing the seat seal.....	18
8.6. Disassembly and assembly of the actuator	19
8.7. Configuration of the actuator.....	20
9. Technical Specifications	
9.1. Valve	21
9.2. Actuator	21
9.3. Materials.....	21
9.4. Sizes available	21
9.5. Weights of the INNOVA G valve	22
9.6. Dimensions of the INNOVA G valve	22
9.7. Exploded drawing and parts list of the INNOVA G valve	23

2. Generalities

2.1. INSTRUCTIONS MANUAL

This manual contains information about the reception, installation, operation, assembly, disassembly and maintenance of the INNOVA G valve.

Carefully read the instruction prior to starting the agitator, familiarize yourself with the installation, operation and correct use of the agitator and strictly follow the instructions. These instructions should be kept in a safe location near the installation area.

The information published in the instruction manual is based on updated data.

INOXPA reserves the right to modify this instruction manual without prior notice.

2.2. COMPLIANCE WITH THE INSTRUCTIONS

Not following the instructions may impose a risk for the operators, the environment and the machine, and may cause the loss of the right to claim damages.

This non-compliance may cause the following risks:

- failure of important machine/plant functions,
- failure of specific maintenance and repair procedures,
- possible electrical, mechanical and chemical hazards,
- risk to the environment due to the type of substances released.

2.3. WARRANTY

Any warranty will be void immediately and lawfully and, additionally, INOXPA will be compensated for any civil liability claims submitted by third parties, in the following cases:

- the service and maintenance work have not been carried out in accordance with the service instructions, the repairs have not been carried out by our personnel or have been carried out without our written authorisation,
- modifications have been carried out on our material or equipment without written authorisation,
- the parts or lubricants used are not original INOXPA parts and products,
- the material or equipment has been improperly used, has been used negligently, or has not been used according to the instructions and their intended.

The General Conditions of Delivery already in your possession are also applicable.



The machine may not undergo any modification without prior approval from the manufacturer.

For your safety, only use original spare parts and accessories.

The usage of other parts will relieve the manufacturer of any liability.

Changing the service conditions can only be carried out with prior written authorization from INOXPA.

Please do not hesitate to contact us in case of doubts or if further explanations are required regarding specific data (adjustments, assembly, disassembly, etc.).

3. Safety

3.1. WARNING SYMBOLS



Safety hazard for people in general and/or for equipment



Electric hazard

ATTENTION

Important instruction to prevent damage to the equipment and its function

3.2. GENERAL SAFETY INSTRUCTIONS



Read the instruction manual carefully before installing and starting the valve. Contact INOXPA in case of doubt.

3.2.1. During installation

The [Technical specifications](#) of [chapter 9](#) should always be observed.



The installation and use of the valve should always be in accordance with applicable regulations in regard to health and safety.

Before starting up the valve, check that it is assembled correctly and its shaft is perfectly aligned. Incorrect alignment and/or excessive stress during coupling can cause serious mechanical problems in the valve.

3.2.2. During operation

The [Technical specifications](#) of [chapter 9](#) should always be observed.



The specified limit values shall never be exceeded under any circumstance.

NEVER touch the valve and/or piping that is in contact with the fluid during operation. If the process involves hot products, there is a risk of burns.

The valve contains parts that move in a linear fashion. Do not place hands or fingers in the valve closing area. This can cause serious injury.

3.2.3. During maintenance

The [Technical specifications](#) of [chapter 9](#) should always be observed.



NEVER disassemble or remove the valve until the pipes have been emptied. Bear in mind that the fluid in the pipe may be hazardous or extremely hot. Consult the regulations in effect in each country for these cases.

Inside the actuator, there is a spring with an applied load, and the steps specified in this manual must be followed when performing maintenance operations to avoid injury. Do not leave loose parts on the floor.



All electrical work must be carried out by authorised personnel.

4. General Information

4.1. DESCRIPTION

The INNOVA G valve is a proportional pneumatically actuated valve designed for flow control in installations of the dairy and food-processing industries, beverage production, pharmaceutical and fine chemicals industries. INNOVA G valves use equal percentage plug to control fluid flow

4.2. APPLICATION

The most important applications are pressure control, flow control, tank level, etc.

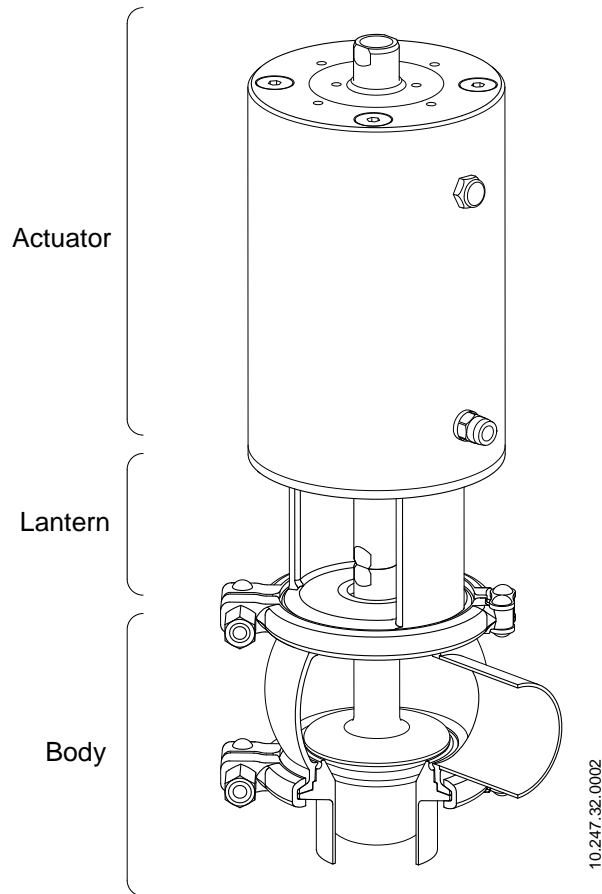

5. Installation

5.1. RECEPTION OF THE VALVE



INOXPA is not liable for any deterioration of the material caused by its transport or unpacking. Visually check that the packaging has not been damaged.

When receipt the valve, check to see whether all the parts listed on the delivery slip are present:

- complete valve,
- its components, if any are supplied,
- delivery slip,
- instruction manual.

INOXPA inspects all its equipment before packaging. However, it cannot guarantee that the merchandise arrives to the user intact.

When receipt the valve:

- remove any possible traces of packaging from the valve or its parts,
- inspect the valve or the parts that comprise it for possible damage incurred during shipping,
- take all possible precautions against damage to the valve and its components.

5.2. TRANSPORT AND STORAGE



The buyer or user shall be liable for assembly, installation, start-up and operation of the valve.

Take all possible precautions when transport and storage the valve to avoid damage it and its components.

5.3. IDENTIFICATION OF THE VALVE

Each valve is inscribed with its fabrication number. Indicate de fabrication number on all documents to refer to the valve.

Fabrication number →	INOXPA S.A.U.		CE EAC
	C. TELERS 60 . 17820 BANYOLES GIRONA (SPAIN) . www.inoxpa.com		
	ITEM: WAGL0-00652050120	SIZE: DN 50	
	TYPE: INNOVA GL DIN EPDM FDA ACT.T2 S/E NC		
	WORKING PRESSURE: 10 bar / 145 psi		
	AIR PRESSURE: Min. 6 bar / 87 psi Max. 8 bar / 116 psi		
	PRODUCTION NR: I254782	YEAR: 2018	

10.247.30.0003

WA	G	L	0	-	0	06	52	025	12	0
										Options
										0 ID Ra < 0,8
										1 ID Ra < 0,5
										Actuator
										11 T1 S/E NC
										12 T2 S/E NC
										13 T3 S/E NC
										14 T4 S/E NC
										21 T1 D/E
										22 T2 D/E
										23 T3 D/E
										24 T4 D/E
										31 T1 S/E NO
										32 T2 S/E NO
										33 T3 S/E NO
										34 T4 S/E NO
										Size
										025 DN 25, OD 1"
										040 DN 40, OD 1 1/2"
										050 DN 50, OD 2"
										063 OD 2 1/2"
										065 DN 65
										076 OD 3"
										080 DN 80
										100 DN 100, OD 4"
										Seals
										43 HNBR
										52 EPDM
										78 FPM
										Material
										06 AISI 316L
										Connection
										0 Welded
										1 Male
										7 Clamp
										Standard pipe
										0 DIN
										1 OD
										Body configuration
										L, T 1 body
										A, B, C, D 2 bodies
										Types
										G Control valve
										Product family
										WA INNOVA valve

5.4. LOCATION

The valve should be installed in a manner that permits to be cleaned, inspected and self-draining. Allow sufficient spacer around the valve for adequate review, dismantling and maintenance. See table in section 5.8. [Welding](#).

Installation shall allow that removable parts shall be readily disassembled.

5.5. DIRECTION OF FLOW

The following image indicates the recommended direction for product flow, as well as the direction of closing. Following these indications will prevent water hammer and its consequences to the extent possible, which can occur when valves close.

The recommended direction will always be contrary to the movement of valve closing, that is, when the valve is closing, the valve will always work against the pressure of the fluid.

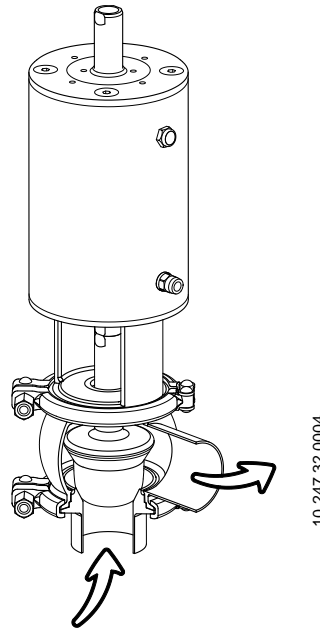

5.6. GENERAL INSTALLATION

After the location of the valve is defined, the pipe can be joined by welding the valve body or using fittings. In this case, do not forget the seals, and tighten the unions properly.

Before starting to weld the valve bodies to the pipe, disassemble the valve to prevent damage to the joints, following the instructions in section 8.4. [Assembly and disassembly of the valve](#).

Avoid using excessive force when assembling the valves, and pay special attention to:

- vibrations that may be produced on the facility,
- thermal dilation that the pipe may undergo when hot fluids are circulating,
- the weight that the pipe can support,
- excessive welding current.

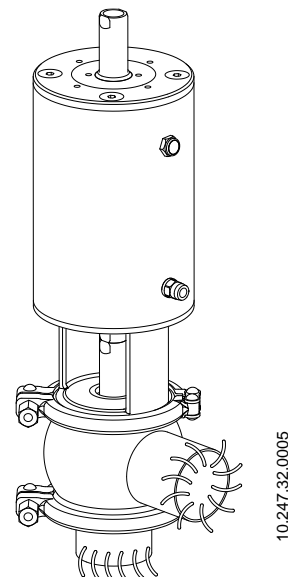

5.7. CHECKING AND REVIEW

Perform the following checks before using:

- check that the clamps and nuts are tightened,
- open and close the valve, applying compressed air to the actuator, several times to make sure it operates correctly and to make sure that the shaft joint is coupled smoothly to the valve body.

5.8. WELDING



Welding work should only be done by qualified persons who are trained and equipped with the necessary equipment to perform this kind of work.

To perform welding work:

- Disassemble the valve as indicated in section 8.4. [Assembly and disassembly of the valve](#),
- Weld the valve body to the pipes,
- When welding the valve body, it is very important to keep the minimum distances (D1, D2 and h) to allow the valve to be disassembled for subsequent reviews and to change valve parts (seals, bushings, etc.).

Valve size	A [mm]	B [mm]
DN 25 / OD 1"	330	520
DN 40 / OD 1 1/2"	350	540
DN 50 / OD 2"	430	620
DN 65 / OD 2 1/2"	500	690
DN 80 / OD 3"	520	710
DN 100 / OD 4"	580	770

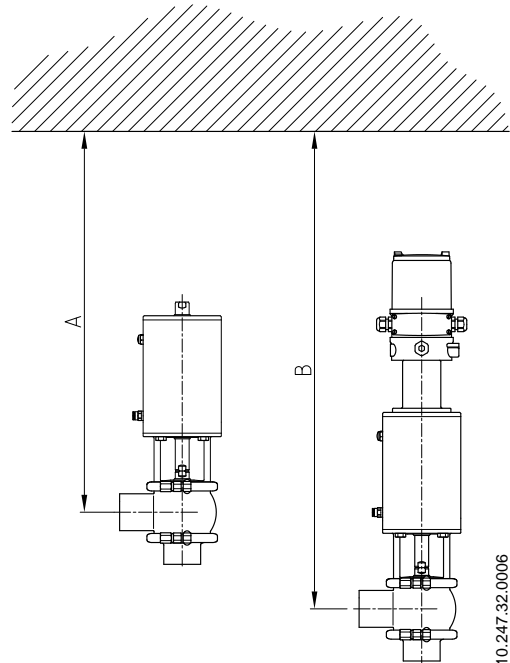

10.247.32.0006

5.9. VALVE CONFIGURATION WITH ACTUATOR

The standard configuration of the valves is NC (normally closed).

It is possible to convert them into NO (Normally Open) simply by turning the valve actuator (see section 8.8.3 [Actuator configuration](#)).

Valves can also be configured as DE valves (double effect).



Never disassemble the valve clamps directly without Reading the instructions carefully, since the actuator contain a spring inside it with and applied load.

Valve and/or actuator assembly and disassembly should only be done by qualified persons.

5.10. ACTUATOR AIR CONNECTION

- Connect and check the compressed air connections.
- INOXPA valves are supplied with connections for Ø6 pipe, and with a silencer on S/E actuators.
- Consider the quality of the compressed air, according to the specifications described in chapter 9. [Technical specifications](#).

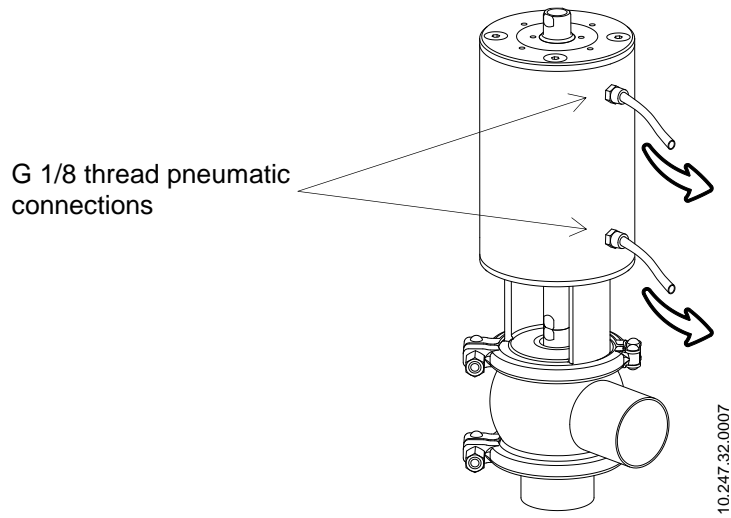

6. Start-up



The start-up of the valve can be carried out provided the instructions indicated in the chapter [5. Installation](#) have been followed.



Prior to start-up, the persons in charge must be duly informed about how the valve Works and the safety instructions to follow. This instruction manual will be available to personnel at all times.

Before putting the valve or the actuator into service, the following must be taken into consideration:

- check that the piping and valve are completely free of possible traces of welding slag or other foreign particles. Clean the system if is necessary,
- check to make sure the valve moves smoothly. If is necessary, lubricate it with special grease or soapy water,
- check for possible leaks, and make sure the pipes and their connections are sealed and do not have any leaks,
- if the valve has been supplied with an actuator, make sure that the alignment, of the valve shaft and the actuator shaft enables smooth movement,
- check that the compressed air pressure at the inlet to the actuator matches what is indicated in the [9. Technical specifications](#),
- consider the quality of the compressed air, according to the specifications described in chapter [9. Technical specifications](#),
- activate the valve.

ATTENTION



Do not modify the operating parameters for which the valve has been designed without prior written authorisation from INOXPA.

Do not touch the moving parts of the coupling between the actuator and the valve when the actuator is connected to the compressed air supply.



¡Burn hazard! Do not touch the valve or the pipes when hot fluids are circulating or when cleaning and/or sterilization are being carried out.

7. Operating problems

Water hammer																											
↓	Valve does not open/close																										
↓	Internal leak of product (valve closed)																										
↓	The valve plug is sticking																										
↓	<table border="1"> <thead> <tr> <th>PROBABLE CAUSES</th> <th>SOLUTIONS</th> </tr> </thead> <tbody> <tr> <td> <ul style="list-style-type: none"> The seal or guide bushing is worn, deteriorated or has gotten stuck </td> <td> <ul style="list-style-type: none"> Replace the seals Replace the seals with ones made of a different material or grade that is more appropriate for the product Lubricate with soapy water or a lubricant that is compatible with the seal material and the product </td> </tr> <tr> <td> <ul style="list-style-type: none"> Insufficient air pressure </td> <td> <ul style="list-style-type: none"> Replace the actuator with a larger one Increase the compressed air pressure </td> </tr> <tr> <td> <ul style="list-style-type: none"> Incorrect configuration of control top </td> <td> <ul style="list-style-type: none"> Adjust control top parameters according to needs </td> </tr> <tr> <td> <ul style="list-style-type: none"> Normal wear of seals </td> <td> <ul style="list-style-type: none"> Replace the seals. </td> </tr> <tr> <td> <ul style="list-style-type: none"> Premature wear of the seal / affected by the product </td> <td> <ul style="list-style-type: none"> Replace the seals with ones made of a different material or grade that is more appropriate for the product. Reduce the pressure in the line Reduce the working temperature </td> </tr> <tr> <td> <ul style="list-style-type: none"> Product residue has been deposited on the valve seat and/or plug </td> <td> <ul style="list-style-type: none"> Clean frequently </td> </tr> <tr> <td> <ul style="list-style-type: none"> Excess product pressure </td> <td> <ul style="list-style-type: none"> Replace the actuator with a larger one Connect an auxiliary compressed air nipple on the side of the spring (to offset the excess pressure) without exceeding (4 bar) Reduce the product pressure </td> </tr> <tr> <td> <ul style="list-style-type: none"> Loss of seal (vibrations) </td> <td> <ul style="list-style-type: none"> Tighten loose parts </td> </tr> <tr> <td> <ul style="list-style-type: none"> Product pressure exceeds the actuator specifications </td> <td> <ul style="list-style-type: none"> Replace the actuator with a larger one Reduce the product pressure Use auxiliary air on the spring side </td> </tr> <tr> <td> <ul style="list-style-type: none"> Warping of seals </td> <td> <ul style="list-style-type: none"> Replace the seals with ones of a different quality, if they have deteriorated prematurely </td> </tr> <tr> <td> <ul style="list-style-type: none"> Actuator spring in poor condition and/or stuck (dirty) </td> <td> <ul style="list-style-type: none"> Replace spring (clean) </td> </tr> <tr> <td> <ul style="list-style-type: none"> The direction of flow is the same as the direction of closing </td> <td> <ul style="list-style-type: none"> The direction of flow should go against the direction of closing Choke the air discharge to reduce the pressure </td> </tr> </tbody> </table>	PROBABLE CAUSES	SOLUTIONS	<ul style="list-style-type: none"> The seal or guide bushing is worn, deteriorated or has gotten stuck 	<ul style="list-style-type: none"> Replace the seals Replace the seals with ones made of a different material or grade that is more appropriate for the product Lubricate with soapy water or a lubricant that is compatible with the seal material and the product 	<ul style="list-style-type: none"> Insufficient air pressure 	<ul style="list-style-type: none"> Replace the actuator with a larger one Increase the compressed air pressure 	<ul style="list-style-type: none"> Incorrect configuration of control top 	<ul style="list-style-type: none"> Adjust control top parameters according to needs 	<ul style="list-style-type: none"> Normal wear of seals 	<ul style="list-style-type: none"> Replace the seals. 	<ul style="list-style-type: none"> Premature wear of the seal / affected by the product 	<ul style="list-style-type: none"> Replace the seals with ones made of a different material or grade that is more appropriate for the product. Reduce the pressure in the line Reduce the working temperature 	<ul style="list-style-type: none"> Product residue has been deposited on the valve seat and/or plug 	<ul style="list-style-type: none"> Clean frequently 	<ul style="list-style-type: none"> Excess product pressure 	<ul style="list-style-type: none"> Replace the actuator with a larger one Connect an auxiliary compressed air nipple on the side of the spring (to offset the excess pressure) without exceeding (4 bar) Reduce the product pressure 	<ul style="list-style-type: none"> Loss of seal (vibrations) 	<ul style="list-style-type: none"> Tighten loose parts 	<ul style="list-style-type: none"> Product pressure exceeds the actuator specifications 	<ul style="list-style-type: none"> Replace the actuator with a larger one Reduce the product pressure Use auxiliary air on the spring side 	<ul style="list-style-type: none"> Warping of seals 	<ul style="list-style-type: none"> Replace the seals with ones of a different quality, if they have deteriorated prematurely 	<ul style="list-style-type: none"> Actuator spring in poor condition and/or stuck (dirty) 	<ul style="list-style-type: none"> Replace spring (clean) 	<ul style="list-style-type: none"> The direction of flow is the same as the direction of closing 	<ul style="list-style-type: none"> The direction of flow should go against the direction of closing Choke the air discharge to reduce the pressure
PROBABLE CAUSES	SOLUTIONS																										
<ul style="list-style-type: none"> The seal or guide bushing is worn, deteriorated or has gotten stuck 	<ul style="list-style-type: none"> Replace the seals Replace the seals with ones made of a different material or grade that is more appropriate for the product Lubricate with soapy water or a lubricant that is compatible with the seal material and the product 																										
<ul style="list-style-type: none"> Insufficient air pressure 	<ul style="list-style-type: none"> Replace the actuator with a larger one Increase the compressed air pressure 																										
<ul style="list-style-type: none"> Incorrect configuration of control top 	<ul style="list-style-type: none"> Adjust control top parameters according to needs 																										
<ul style="list-style-type: none"> Normal wear of seals 	<ul style="list-style-type: none"> Replace the seals. 																										
<ul style="list-style-type: none"> Premature wear of the seal / affected by the product 	<ul style="list-style-type: none"> Replace the seals with ones made of a different material or grade that is more appropriate for the product. Reduce the pressure in the line Reduce the working temperature 																										
<ul style="list-style-type: none"> Product residue has been deposited on the valve seat and/or plug 	<ul style="list-style-type: none"> Clean frequently 																										
<ul style="list-style-type: none"> Excess product pressure 	<ul style="list-style-type: none"> Replace the actuator with a larger one Connect an auxiliary compressed air nipple on the side of the spring (to offset the excess pressure) without exceeding (4 bar) Reduce the product pressure 																										
<ul style="list-style-type: none"> Loss of seal (vibrations) 	<ul style="list-style-type: none"> Tighten loose parts 																										
<ul style="list-style-type: none"> Product pressure exceeds the actuator specifications 	<ul style="list-style-type: none"> Replace the actuator with a larger one Reduce the product pressure Use auxiliary air on the spring side 																										
<ul style="list-style-type: none"> Warping of seals 	<ul style="list-style-type: none"> Replace the seals with ones of a different quality, if they have deteriorated prematurely 																										
<ul style="list-style-type: none"> Actuator spring in poor condition and/or stuck (dirty) 	<ul style="list-style-type: none"> Replace spring (clean) 																										
<ul style="list-style-type: none"> The direction of flow is the same as the direction of closing 	<ul style="list-style-type: none"> The direction of flow should go against the direction of closing Choke the air discharge to reduce the pressure 																										

8. Maintenance

8.1. GENERAL CONSIDERATIONS

This valve, just like any other machine, requires maintenance. The instructions in this manual cover the identification and replacement of spare parts. The instructions are aimed at maintenance personnel and those responsible for the supply of spare parts.



Carefully read chapter 9. [Technical specifications](#).

All replaced material should be duly disposed of/recycled according to the directives in effect in each area.

Valve and/or actuator assembly and disassembly should only be done by qualified persons.

Before starting maintenance work, make sure that the pipes are not under pressure.

8.2. MAINTENANCE

To perform maintenance properly, the following are recommended:

- periodic inspection of the valve and its components,
- keeping an operational record of each valve, noting any problems,
- always having spare replacement seals in stock.

During maintenance, pay special attention to the hazard warnings indicated in this manual.



The valve and the pipes must never be under pressure during maintenance.

During maintenance, the valve must never be hot. ¡Burn hazard!

8.2.1. Seal maintenance

CHANGING SEALS	
Preventive maintenance	Replace every 12 months
Maintenance after a leak	Replace at the end of the process
Planned maintenance	Regularly check for the absence of leaks and smooth operation of the valve Keep a valve log Use statistics to plan inspections
Lubrication	During assembly, apply lubricants that are compatible with the seal material. See the table below

SEAL COMPONENT	LUBRICANT	NLGI DIN 51818 Class
HNBR/ FPM	Klübersynth UH 1 64-2403	3
EPDM/ HNBR/ FPM	PARALIQ GTE 703	3

The period between each preventive maintenance service will vary depending on the working conditions to which the valve is subject: temperature, pressure, number of operations per day, type of cleaning solutions used, etc.

8.2.2. Storage

Valves should be stored in an enclosed location under the following conditions:

- temperature from 15°C to 30°C,
- ambient humidity < 60%.

Equipment MAY NOT be stored outside.

8.2.3. Spare parts

To order spare parts, you must indicate the valve type, the fabrication number, the position and description of the part, as found in chapter 9. [Technical specifications](#).

8.3. CLEANING



The use of aggressive cleaning products such as caustic soda and nitric acid may burn the skin. Wear rubber gloves during all cleaning procedures. Always wear protective goggles.

8.3.1. CIP (clean-in-place) cleaning

If the valve is installed in a system with a CIP process, its disassembly will not be required. EPDM is the standard seal material that will be used for CIP cleaning, both in alkaline mediums and in acid mediums. The other two options (HNBR, FPM) are not recommended.

Cleaning solutions for CIP processes:

Only use clear water (chlorine-free) to mix with the cleaning agents:

a) Alkaline solution: 1% by weight of caustic soda (NaOH) at 70°C (150°F)

1 Kg NaOH + 100 l H₂O = cleaning solution

or

2,2 l NaOH al 33% + 100 l H₂O = cleaning solution

b) Acid solution: 0,5% by weight of nitric acid (HNO₃) at 70°C (150°F)

0,7 l HNO₃ al 53% + 100 l H₂O = cleaning solution

ATTENTION



Check the concentration of the cleaning solutions; incorrect concentrations may lead to the deterioration of the valve seals.

To remove any traces of cleaning products, ALWAYS perform a final rinse with clean water at the end of the cleaning process.



Before starting disassembly and assembly tasks, clean the entire interior and exterior of the valve.

8.3.2. Automatic SIP (sterilization-in-place)

Sterilization with steam is applied to all equipment including the pigging.

ATTENTION



Do NOT start the equipment during the sterilization with steam.

The parts/materials will not be damaged if the indications specified in this manual are observed.

No cold fluid can enter the equipment until the temperature of the equipment is lower than 60°C (140°F).

Maximum conditions during the SIP process with steam or superheated water:

- a) Max. temperature: 140°C / 284°F
- b) Max. time: 30 min
- c) Cooling: Sterile air or inter gas
- d) Materials: EPDM (HNBR and FPM are not recommended)

8.4. ASSEMBLY AND DISASSEMBLY OF THE INNOVA G VALVE



Proceed with caution. Personal injury can occur.

Always disconnect the compressed air before starting to disassemble the valve.

Never disassemble the valve clamps directly without Reading the instructions carefully, since the actuator contains a spring inside it with an applied load.

Valve and/or actuator assembly and disassembly should only be done by qualified persons.

8.4.1. Disassembly

1. Apply compressed air to the actuator (10) so that the plug shaft (08) passes the open position (only NC valves).
2. Loosen and separate the clamp (34).
3. Separate the actuator (10) from the valve housing (01).
4. Remove seal (20B) from bottom port (02).
5. Release the compressed air in the actuator (only NC valves).
6. Unscrew the allen screws (23) from the lantern (21).
7. Unscrew the plug shaft (08) from the actuator shaft two 17 mm crescent spanners.
8. Finish unscrewing the plug shaft by hand.
9. Once the plug shaft is out, remove the housing cap (12) and the seals inside it (20B and 05).
10. Remove the guide bushing (17).
11. Remove seat seals (05C and 05E) as explained in section [8.6. Replacing the seat seal](#).

8.4.2. Assembly

1. Install the guide bushing (17) on the lantern (21).
2. Insert the lantern (21) underneath the actuator.
3. Lubricate the seals with soapy water if is necessary.
4. Install the seals (20B and 05) in the housing cap (12) and put this assembly in the lantern.
5. Install the seat seal (05C and 05D) as described in section [8.6. Replacing the seat seal](#).
6. Screw the plug shaft (08) with the actuator shaft (10).
7. Tighten the four allen screws (23) that secure the lantern (21) to the actuator.
8. Apply compressed air to the actuator so that the plug shaft (08) is in the open position (only for NC valves).
9. Assembly bottom port (02) and intermediate housing (01) and secure it using clamps (34).
10. Mount the actuator (10) – lantern (21) – plug shaft (08) – housing cap (12) assembly to the valve housing (01) (can be turned 360° according to the user's need) and secure it using the clamp (34).
11. Release the compressed air in the actuator (only NC valves).
12. Open and close the valve several times applying compressed air to the actuator to make sure it operates correctly and the shaft seal fits smoothly with the body valve.

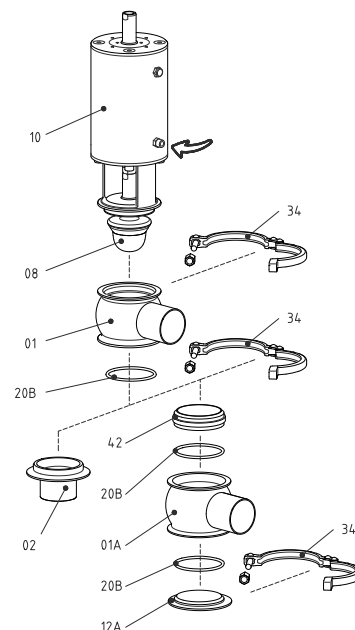

10.247.32.0008

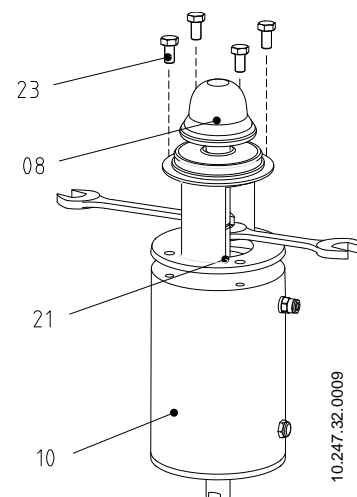

10.247.32.0009

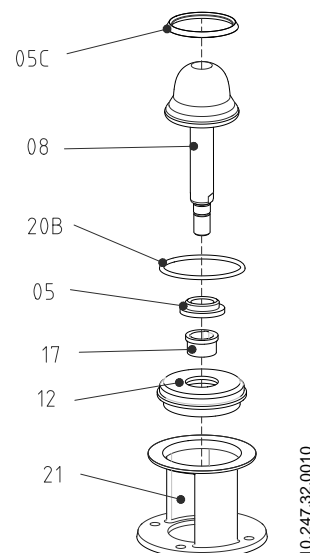

10.247.32.0010

See section [9.7. Exploded drawing and parts list of the INNOVA G valve](#) for a reference to the parts described.

8.5. REPLACING THE SEAT SEAL

1. Put the plug shaft in a vertical position –for example, with a bench clamp- so that the shaft is kept stable and no damage is caused to the mating surface of the conical seal. Do not press the shaft too much if using a bench clamp.
2. Remove the used seal using a screw driver or a sharp hook-shaped tool. Make sure not to damage the mating surface of the seal.
3. Lubricate the new seat seal with soapy water if necessary to facilitate installation.
4. Insert the seal in the plug shaft seat accommodation so that its edges are inside the accommodation. Preferably the seal should fit within the part of the section that has the greatest diameter, as shown in the figure.
5. Then, with the help of an appropriate tool (not piercing), press the edge of the seal that hasn't yet fit into the accommodation, as shown in the figure.
6. This operation should be done around the entire diameter, applying the tool in the sequence **1-2-3-4-5-6-7-8** as shown in the bottom figure. Always press on opposite sides.
7. Repeat the process until the seal is completely inside the accommodation.
7. Press the seal with your fingers to make sure it is well seated. Make sure there are no parts projecting due to poor positioning of the seal.

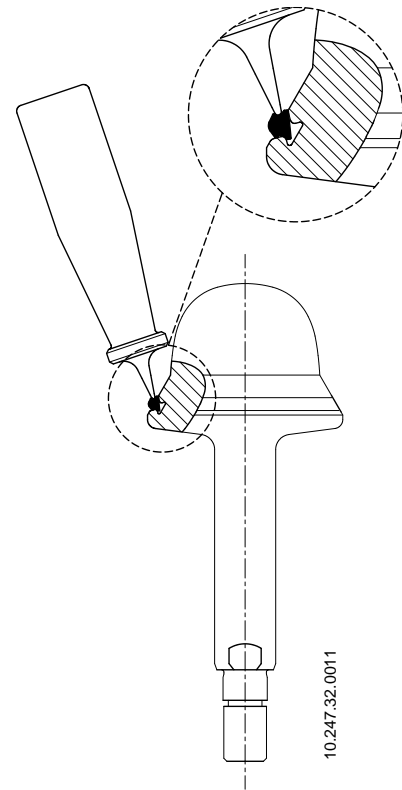

10.247.32.0011

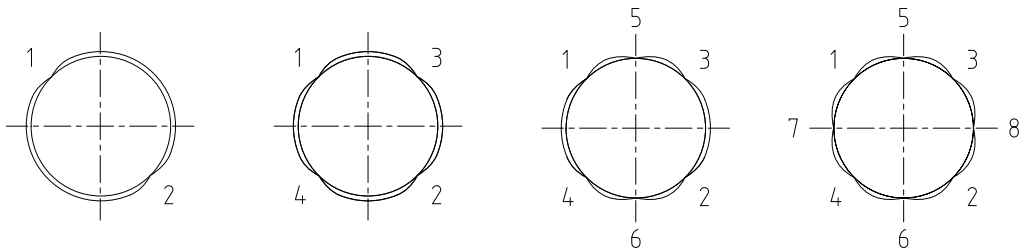

10.240.32.0017

The following tools are needed to assembly or disassembly the valve:

- 2 crescent spanners 15 mm to remove the plug shaft DN 25,
- 2 crescent spanners 17 mm to remove the plug shaft DN 40 to DN 100,
- a crescent spanner 13 mm for remove the clamps,
- appropriate tool (not piercing) to mount the seat seals,
- allen key as per the table:

Zone	DN 25/40	DN 50/65/80	DN 100
Cap	4 mm	5 mm	8 mm

- crescent spanner as per the table:

Zone	DN 25/40	DN 50/65/80	DN 100
Lantern	10 mm	13 mm	19 mm



Proceed with caution. Personal injury can occur.
Never directly disassembly the clamps from the valve reading the instructions carefully.



ATTENTION

Valve/actuator assembly and disassembly should only be done by qualified persons.

8.6. DISASSEMBLY AND ASSEMBLY OF THE ACTUATOR

Do not apply compressed air until the disassembly/assembly process is completed. The figure is a schematic representation of some of the steps in the actuator disassembly process.

8.6.1. Disassembly

1. Loosen the 4 bolts (32) and remove the cap (39).
2. Remove the air fitting (18A).
3. Situate the actuator in the base of the clamp or in the lathe collet. A thick tube (102) and a shim (101) must be used on the free end of the actuator.
4. Apply force to the shim. Once the cover (12) has dropped 15 – 20 mm, remove the snap ring (45). This should have sufficient free space to be able to remove it.
5. Reduce the force on the shim slowly until the top cover is free (you will note that the spring no longer exerts pressure).
6. Remove the cover (12) and the internal components, spring assembly (06) and piston (30).
7. Dismount the scraper (60), seal (20B) and guide (11) from the base of the actuator.

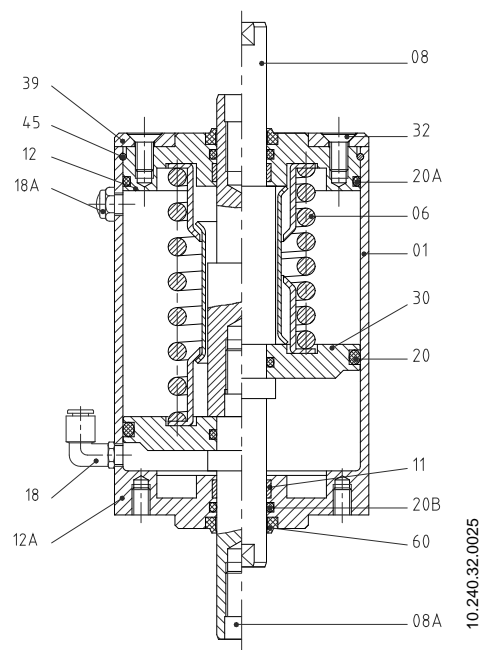

8.6.2. Assembly

1. Mount the scraper (60), seal (20B) and guide (11) on the base of the actuator.
2. Mount the seals (20A and 20B), the scraper (60) and the guide (11) for the cover (12).
3. Put the seals (20 and 20C) on the piston (30).
4. Put the piston (30) and the spring assembly (06) inside the cylinder (01).
5. Mount the top cover (12) on the cylinder.
6. Apply force to the shim so it lowers 15 – 20 mm. Insert the snap ring (45).
7. Reduce the force applied slowly until the tool no longer touches the cover.
8. Install the counter cover (3) and screw in the 4 bolts (32).
9. Install air fitting (18A).
10. Apply compressed air to check the proper functioning of the actuator

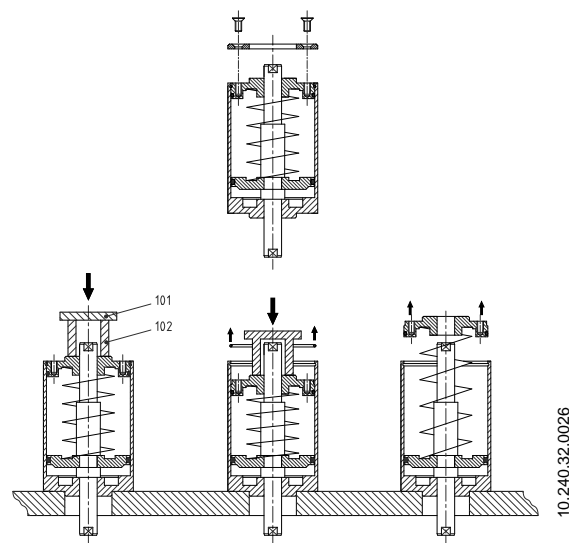

8.7. CONFIGURATION OF THE ACTUATOR

The standard configuration of the valve is NC (normally closed).

If a NO (normally open) valve is needed, turn the actuator 180°. The following figure shows the orientation of the actuator depending on the desired actuator configuration.

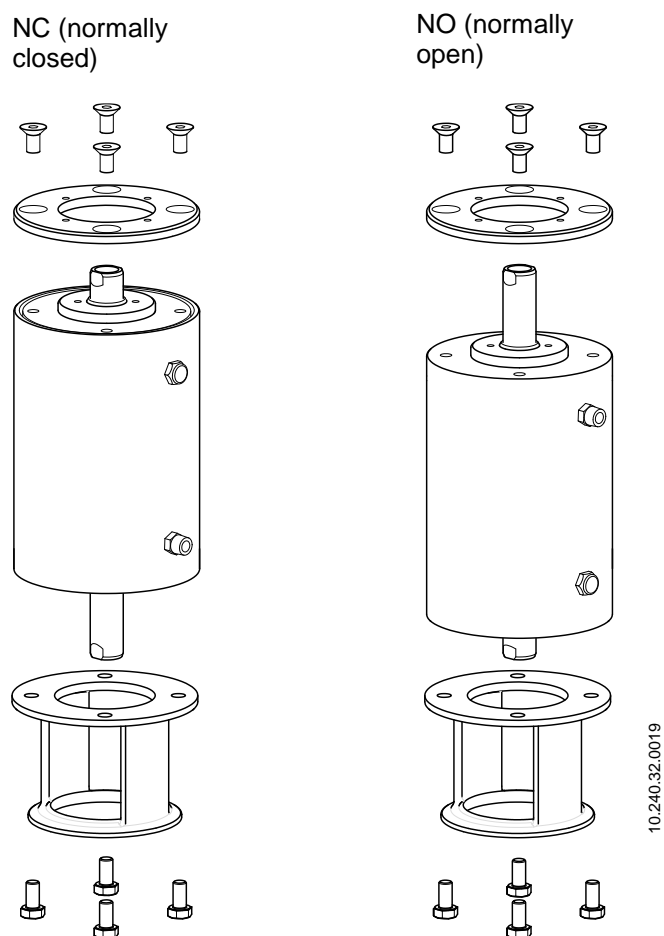

The following tools are needed to assembly or disassembly the valve:

- an allen spanner 4 mm for size DN 25 to DN40, an allen spanner 5 mm for size DN50 to DN80 and an allen spanner 8 mm for size DN 100,
- fine point screw driver to remove the snap ring,
- vice or lathe (to compress the spring and enable the actuator to be opened).

9. Technical Specifications

9.1. VALVE

Maximum working pressure	10 bar
Minimum working pressure	Vacuum
Working temperature	121°C (250°F) standards seals EPDM (for higher temperatures, other grades of seals will be used)

9.2. ACTUATOR

Compressed air pressure	6 - 8 bar
Compressed air quality	per DIN/ISO 8573.1: <ul style="list-style-type: none"> - <u>Solid particulate content</u>: quality class 3 / max. particle dimension 5 microns / max. particle density 5 mg/m³. - <u>Water content</u>: quality class 4 / max dew point = 2°C. If the valve is used at high altitude or under low ambient temperature conditions, the dew point must be adjusted accordingly. - <u>Oil content</u>: quality class 5, preferentially oil free, maximum 25 mg oil per 1m³ air.

Compressed air fitting G 1/8
 Compressed air consumption (litres N/cycle)

DN	SE (Single effect)	DE (Double effect)
25	1,1	3,2
40	1,1	3,2
50	2,6	8,5
65	4,9	17,7
80	4,9	17,7
100	10,6	42,3

9.3. MATERIALS

Parts in contact with the product	AISI 316L
Other steel parts	AISI 304
Seals in contact with the product	EPDM – FPM – HNBR
Internal surface finish	Polished Ra ≤ 0,8 µm
Outer surface finish	Matt

9.4. SIZES AVAILABLE

DIN EN 10357 series A (formerly DIN 11850 series 2)	DN 25 – DN 100
ASTM A269/270 (correspond to OD tube)	OD 1” – OD 4”
Connections	Welded

9.5. WEIGHTS OF THE INNOVA G VALVE

	DN	Weight (kg)	
		1 body	2 bodies
DIN	25	4,5	5,0
	40	5,6	6,3
	50	10	11
	65	17	19
	80	19	21
	100	34	37
OD	1"	4,5	5,0
	1 1/2"	5,5	6,3
	2"	10	11,0
	2 1/2"	17	18
	3"	18	20
	4"	34	37

9.6. DIMENSIONS OF THE INNOVA G VALVE

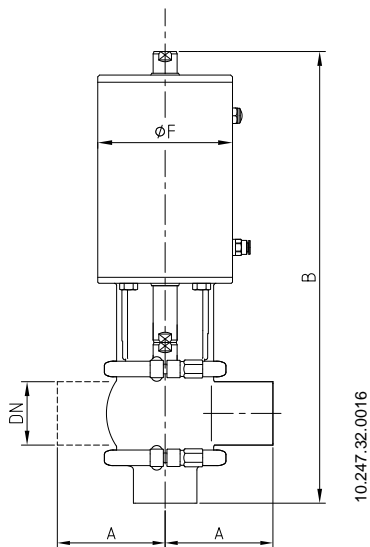

DN	Dimensions (mm)		
	A	B	ØF
25	50	304	87
40	85	325	87
DIN	50	90	404
	65	110	476
	80	125	483
	100	150	542
OD	1"	50	302
	1 1/2"	85	323
	2"	90	403
	2 1/2"	110	473
	3"	125	479
	4"	150	541

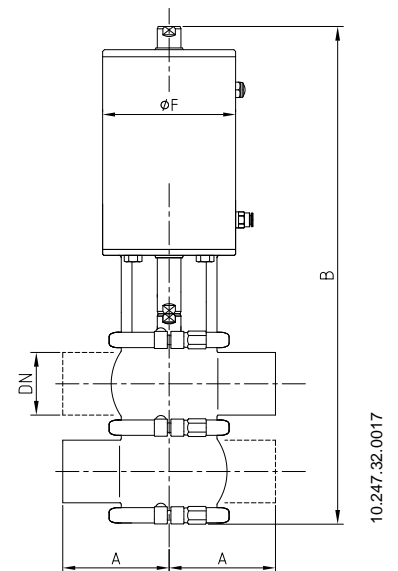

DN	Dimensions (mm)		
	A	B	ØF
25	50	336	87
40	85	363	87
DIN	50	90	448
	65	110	529
	80	125	543
	100	150	612
OD	1"	50	332
	1 1/2"	85	359
	2"	90	446
	2 1/2"	110	523
	3"	125	535
	4"	150	610

9.7. EXPLODED DRAWING AND PARTS LIST OF THE INNOVA G VALVE

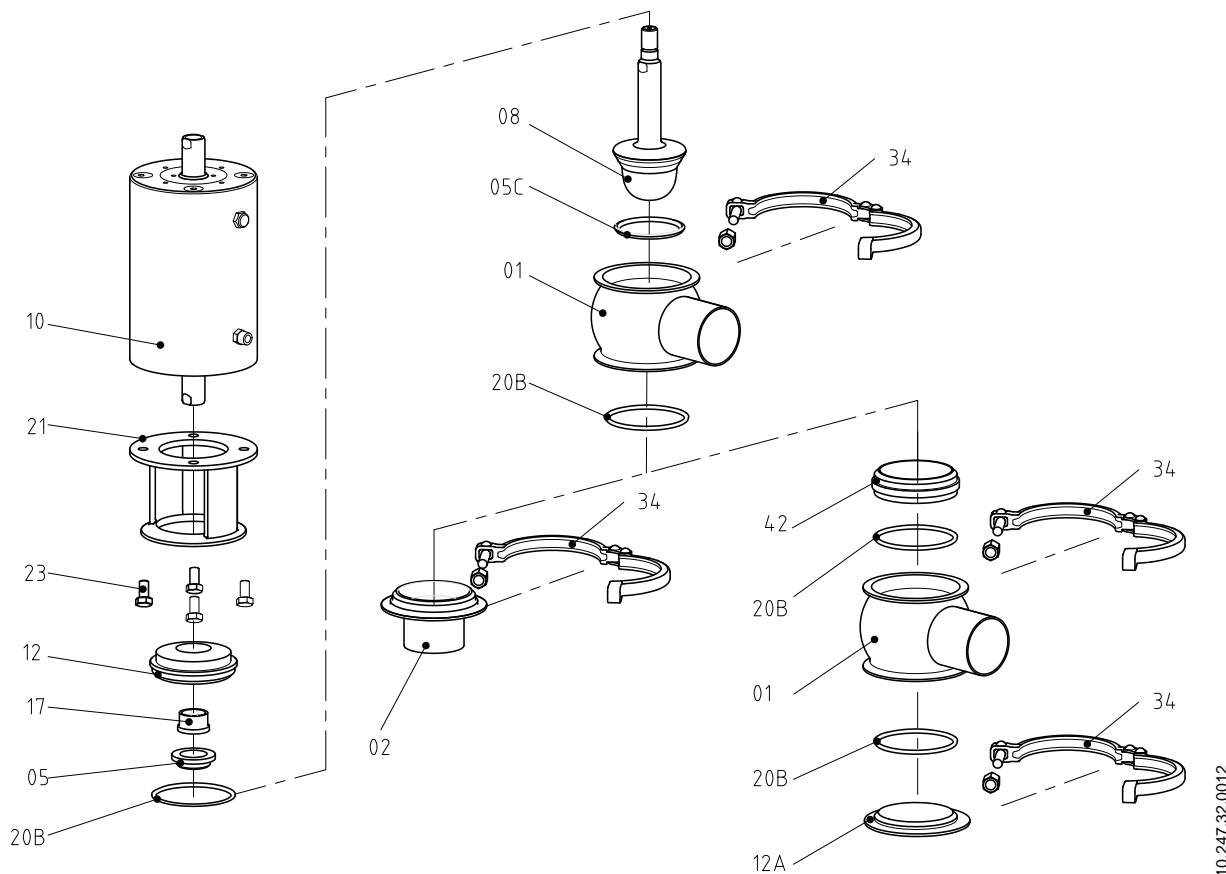

Position	Description	Quantity		Material
		A ¹	B ²	
01	Intermediate housing	1	2	AISI 316L
02	Bottom port	1	-	AISI 316L
05	Shaft seal*	1	1	EPDM / FPM / HNBR
05C	Shaft seal*	1	1	EPDM / FPM / HNBR
08	Valve shaft	1	1	AISI 316L
10	Actuator	1	1	AISI 304
12	Housing cap (upper bushing)	1	1	AISI 316L
12A	Housing cap (bottom bushing)	-	1	AISI 316L
17	Guide bushing*	1	1	PTFE
20B	O-ring*	2	4	EPDM / FPM / HNBR
21	Lantern	1	1	AISI 304
23	Hexagonal screw	4	4	A2
34	Clamp	2	3	AISI 304
42	Separator	-	1	AISI 316L

¹ A: 1 body (L/T)

² B: 2 bodies (A/B/C/D)

* recommended spare parts

How to contact INOXPA S.A.U.:

Contact details for all countries are continually updated on our website.

Please visit www.inoxpa.com to access the information.



INOXPA S.A.U.

Telers, 60 – 17820 – Banyoles – Spain

www.sks-online.com

Tel.: +34 972 575 200 – Fax: +34 972 575 502