



## Alfa Laval Sight Glass according to DIN 28120

Bolted sight glass for visual inspection of product in vessels in hygienic applications

### Introduction

The Alfa Laval Sight Glass according to DIN 28120 is a sight glass that permits direct distortion-free visual inspection of process conditions, products, liquid levels and cleaning inside vessels. It is typically used for high-pressure, high-temperature processes.

Affordable and easy-to-operate, the leakproof sight glass makes it possible for operators to view the color, clarity, turbidity, or other critical characteristics of the product or cleaning status inside the vessel.

Inspection enables early detection of potential issues and quick response. This helps prevent costly downtime, protect plant equipment and improve operational efficiency.

### Application

The sight glass is designed for use in high-pressure, high-temperature hygienic applications across the dairy, food, beverage, brewery, chemical, personal care, biotechnology, pharmaceutical and many other industries.

### Benefits

- Improved operational efficiency
- Enables early detection and quick response to potential issues
- Reliable operation and more uptime
- Quick and easy to install
- Low maintenance requirements

### Standard design

Engineered with a welding nozzle, the sight glass consists of a base flange, cover flange, gaskets, borosilicate glass disc, grooved collar nut, nuts and studs.

Dimensioned according to DIN 28120, the flange thicknesses guarantee distortion-free positioning of the sight glass disc, provided that the flanges are properly welded into or onto the wall of the vessel.

The pressure resistance of the glass disc is dependent on the care with which the bolts and nuts are tightened (always work on diametrically opposed pairs). For lubricated bolts with  $R_a = 0.1$  mm, the recommended tightening torque values (Nm) are indicated in the table on page 2.



Made of borosilicate, the glass disc is able to withstand operating temperatures up to 280°C (DIN 7080). All steel parts are available with material certificate EN10204. 3.1B/AD-W2.

Available in sizes from DN 50 – DN 200, the sight glass can be fitted with an optional Alfa Laval miniVISION Light Fitting.

## TECHNICAL DATA

Temperature	
Temperature range:	-10°C to +140°C (EPDM), (higher temperatures up to 280°C with gaskets of Klingersil)

Pressure	
Max. product pressure:	Max. 10 bar (1000 kPa)
Min. product pressure:	Full vacuum

## PHYSICAL DATA

Materials	
Base flange:	AISI 316L, material certificate 3.1B/AD-W2
Cover flange:	AISI 321, material certificate 3.1B/AD-W2
Gaskets:	Klingersil C4400 (cover side)/EPDM (product side)
Glass disc:	Borosilicate to DIN 7080, material certificate 2.2 (max. 280°C)
Bolts or studs:	To DIN 938/934 in A2-70

## Dimensions (mm)

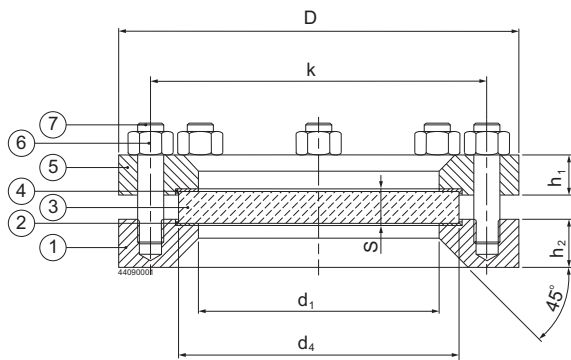

Size DIN	Pressure Rating	Viewing Diameter	Sight glass disc		Base flange and cover flange				Bolts or studs and nuts		
			d1	d4	D	k	h1	h2	Number	Size	Tightening torque (Nm)
50	10	80	100	15	165	125	16	30	4	M16	28
80	10	100	125	15	200	160	20	30	8	M16	20
100	10	125	150	20	220	180	22	30	8	M16	26
125	10	150	175	20	250	210	25	30	8	M16	32
150	10	175	200	25	285	240	30	36	8	M20	47
200	10	225	250	30	340	295	35	36	8	M20	63

## Installation

The numbers in the following installation instructions refer to the drawing above.

After having correctly welded the base flange (1) onto or into the vessel wall, the gasket (2), the sight glass disc (3), the gasket (4) and the cover flange (5) are mounted one after the other and then the nuts (6) are tightened, always working on diametrically opposite pairs. The above indicated tightening torque values have to be strictly respected. Additional information may be taken from the DIN specification 28120.

## Options

- Product wetted side of gasket in Klingersil C4400.
- miniVISION light fitting.

## Ordering

When ordering, please state the following:

- DN size.
- Material type of product wetted gasket side.
- miniVISION light fitting, if needed.

Alfa Laval reserves the right to change specifications without prior notification.

---

**How to contact Alfa Laval**

Contact details for all countries are continually updated on our website. Please visit [www.alfalaval.com](http://www.alfalaval.com) to access the information direct.