

# Operating Instructions

## ASI Control Head for Lift and Turning Valves



Subject to technical modifications and innovations.

[www.sks-online.com](http://www.sks-online.com)

**Contents:**

<b>1</b>	<b>General information</b>
1.1	List of figures and diagrams
<b>2</b>	<b>Technique and application</b>
2.1	Function of the control head
2.2	Design of the control head
2.3	Control of the actuator
2.4	Positioning
2.5	ES technique
2.6	Application
2.7	Setting of the actuator types
2.8	LED signalling
<b>3</b>	<b>Electrical connections</b>
3.1	Electrical connection L and P 4-contacts connector
3.2	Electrical connection P 2-contacts connector
3.3	Electrical connection P 5-contacts connector
3.4	Electrical connection external ASI 4-contacts connector
3.5	Electrical connection external inputs 5-contacts socket
3.6	Technical data
<b>4</b>	<b>Dimensions and mounting</b>
<b>5</b>	<b>Adjustment of magnetic encoder of lift valves</b>
<b>6</b>	<b>Symbols and references</b>
6.1	Used symbols
6.2	Used terms
6.3	Safety requirements
6.4	Dangers
<b>7</b>	<b>Mounting / Commissioning</b>
7.1	Mounting of the control head
7.2	Required tools for mounting and dismounting
7.3	Commissioning
7.4	Integration into a plant
7.5	Mounting of the control head
7.6	Dismounting of the control head
<b>8</b>	<b>Spare and wear parts</b>
<b>9</b>	<b>Transport</b>
9.1	Delivery scope
9.2	Transport and packaging
<b>10</b>	<b>Trouble-shooting</b>
10.1	Emergency stop
<b>11</b>	<b>Disposal</b>
<b>12</b>	<b>Annex 1</b> Alteration to forerunner model
12.1	<b>Annex 2</b> Switching example
<b>13</b>	<b>Annex 3</b> control ASI VB
<b>14</b>	<b>Annex 4</b> control ASI special VB

## 1 General information

---



These operating instructions are part of the control head and must be at the user's disposal at any time. Every safety instruction is to be made sufficiently known and to be observed. If the unit is passed on, the operating instructions must be passed on as well.

---

### 1.1 List of figures and diagrams

Fig. 1	Control head	
Fig. 2	Design of the control head	
Fig. 3	Magnet carrier and encoder	
Fig. 4	Setting of the actuator types	
Fig. 5	Position of the connectors	
Fig. 6	Electrical connections L and P	4-contacts
Fig. 7	Electrical connections ES P	2-contacts
Fig. 8	Electrical connections cycle stroke P	5-contacts
Fig. 9	Dimensions and mounting	
Fig. 10	Earthing spring of stainless steel hood	
Chart 1	Setting of actuator types	
Chart 2	LED signalling	

## 2 Technique and application

### 2.1 Function of the control head

The control head can be combined with the Kieselmann valves. It is put on the valve drive and then screwed down. The touchless magnetic sensor technology allows the application in different valve types. The positions of the valves are acquired over the electronics of the control head and forwarded to a higher-level control. The forwarding of the signals is made via a wiring provided for it. The electronic system signalizes the valve conditions at the control head. The actuator is controlled over the integrated pilot valves. The supply of air is made either directly over the control head or over an external hose coupling. Operation is allowed only in the intended environment.

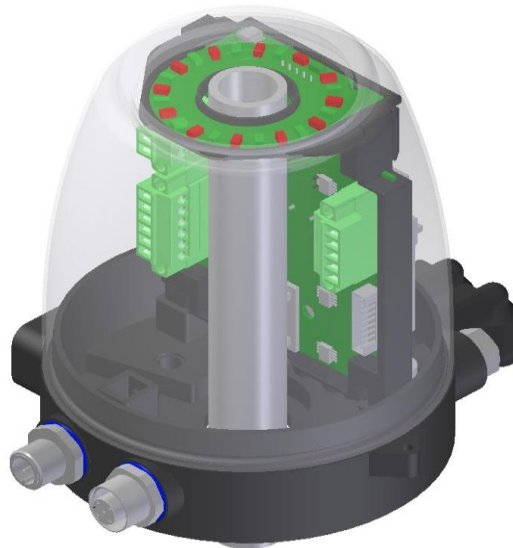

Fig. 1

#### **Important!!**

Assembly of plants must be carried out only by qualified personnel. Take care that wires are kept away from interfering components, such as supply lines from frequency converters. Please consider the definitions of the ASI bus guidance.

## 2.2 Design of the control head

The control head consists of a bottom part with bayonet catch where a plastic or a stainless steel hood can be put on. The housing resulting from it includes an electronic system which allows to control and to acquire the positions of the valve. This electronic system is available as a light and premium version. It is possible to put a 360° viewable display on both the versions. The pilot valves which are integrated, too, control the movement of the actuator. The electrical connections are made over a cable entry in the bottom part. Other connections, such as M12 connectors, are possible as an option, too. Quick release couplings for compressed air provide a connection to the supply air. Stop valves for the entry of air are furnished as an option.

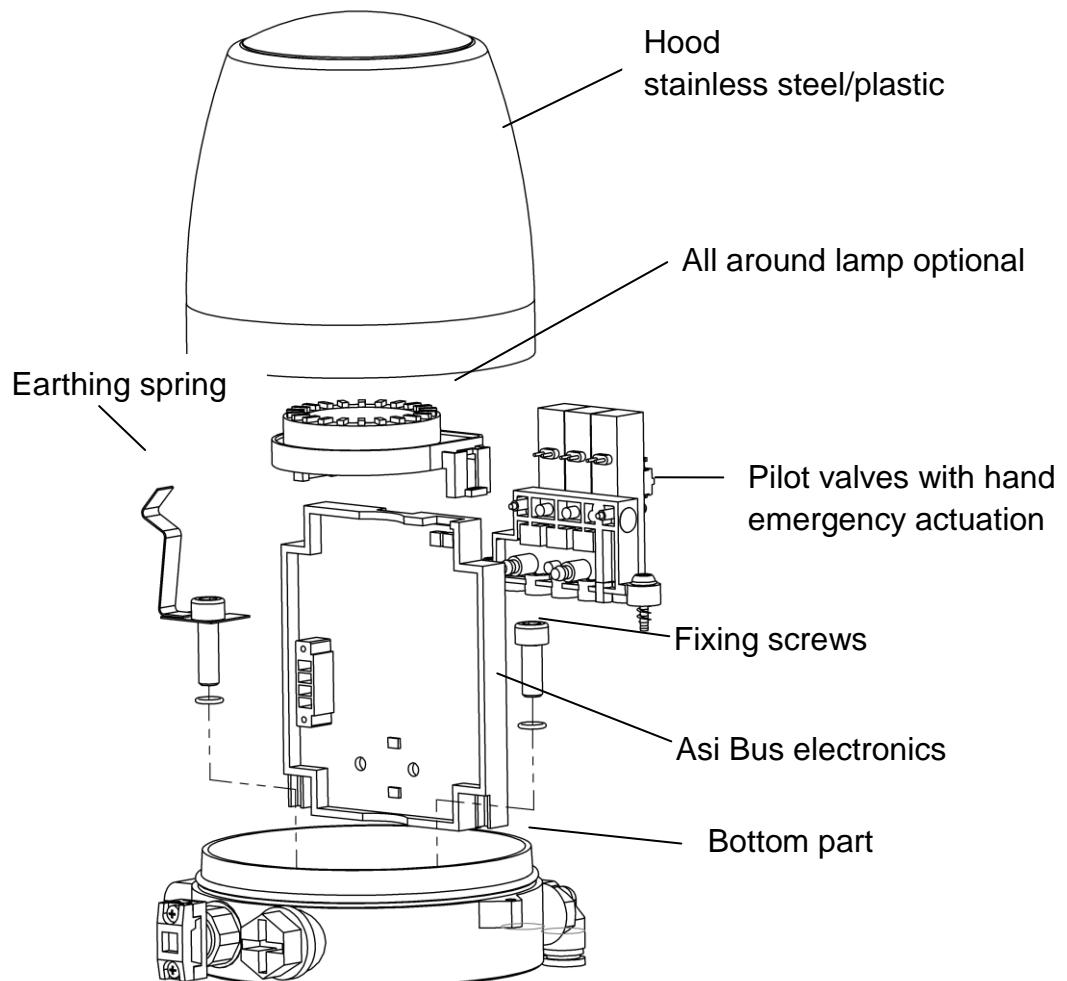

**Fig. 2**

## 2.3 Control of the actuator

The control of the actuator can be made over the installed or external pilot valves. External pilot valves are placed in the switchboard plants of the higher-level control. Internal pilot valves can be triggered over the hand emergency actuation.

## 2.4 Positioning

The position of the actuator is determined over a magnet carrier. This carrier is located in the axle of the valve.

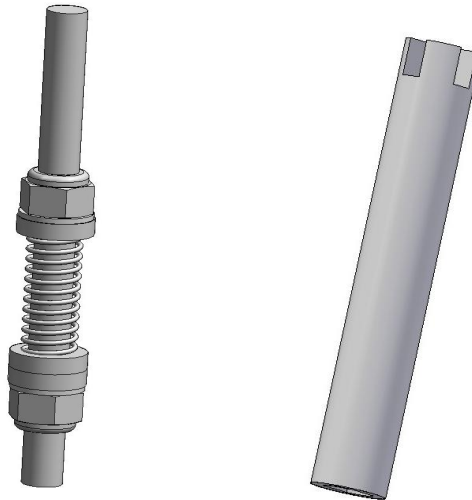

**Fig. 3** lift valve turning valve

## 2.5 ES technique

An external supply of the pilot valves can be fed for the emergency stop of valves. This supply can be interrupted for example over an emergency switch in order to set a certain area of the plant into the STOP condition. All transmitting lines to the higher-level control remain unaffected.

## 2.6 Application

These control heads are suitable for the application on Kieselmann actuators for lift and turning valves. Their range of application is designed for Atex zones 1 and appropriate to gas and dust. The energy-saving variant allows an application in both the ranges.



These control heads are designed to be used only on Kieselmann actuators and must be used only in the intended ranges. Any application other than intended is forbidden. Application must be made only by qualified and instructed persons.

Modifications are not covered by the manufacturer.

## 2.7 Setting of the actuator types

Setting of the valve types is made over a selector switch (S1). The switch positions are allocated to the actuators over the following list.

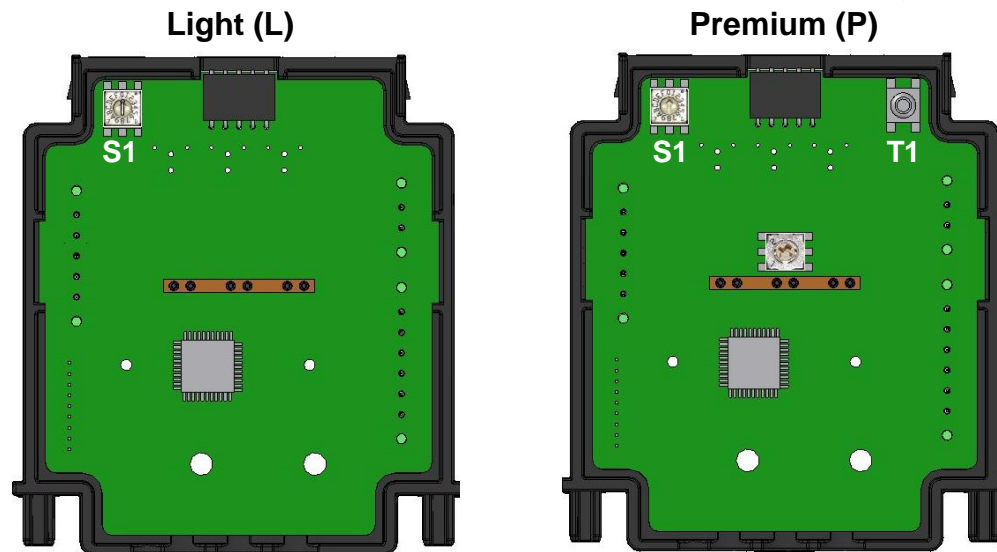

Fig. 4

Actuator designation	Switch (S1)
Double-seat valve cycle above / below without reply	0
Double-seat valve without cycle	1
Double-seat valve only cycle above	2
Double-seat valve with cycle stroke recognition and reply	3
Lift valve air to open / spring to close	4
Lift valve air to open / air to close	5
Lift valve air to close / spring to open	6
Double-seat valve with cycle inverse	7
Turning valve / Flap air to open / spring to close	8
Turning valve / Flap air to open / air to close	9
Turning valve / Flap air to close / spring to open	A
Lift valve air to open / spring to close adaptive	B
Lift valve air to open / air to close separately controllable	C
Turning valve / Flap air to open / air to close sep. controllable	D
Lift valve air to close / spring to open adaptive	E
nu	F

### Chart1



#### **Attention: Type 3, B and E only with premium version**

Please pay special attention to the following when setting type 3:  
In order to read in the positions, key button T1 must be held down while the 4-contacts connector plug is plugged. After release of the key button, the actuator changes to the learning mode and moves to the different positions of the actuator. Now the connector can be screwed down and the cover can be closed.

## 2.9 LED signalling

Signalling of the actuator position through the LED on the board or optionally through the 360° viewable display

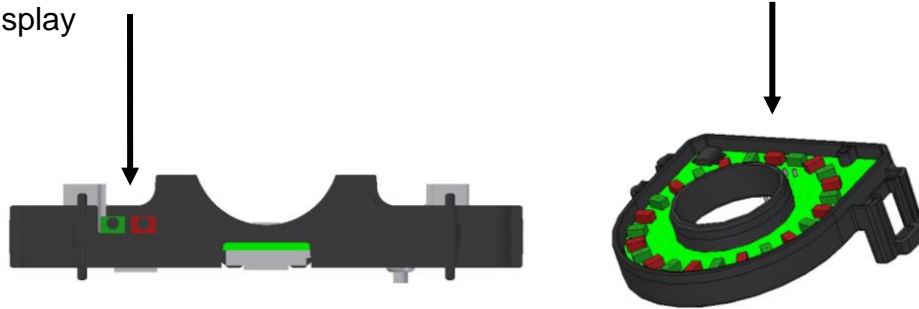

		Note
Valve closed	LED red	
Valve open	LED green	
Valve position not defined	red / green alternating 8 Hz	
Valves with learning mode switch position 3		
Cycle below	LED red flashes	with P version
Cycle above	LED green flashes	with P version
Programming	red / green simultaneously	4Hz
False programming	red flashes	20 Hz
Program error	red / green alternating	4 Hz

### Chart 2



### 3 Electrical connections

#### Position of connectors

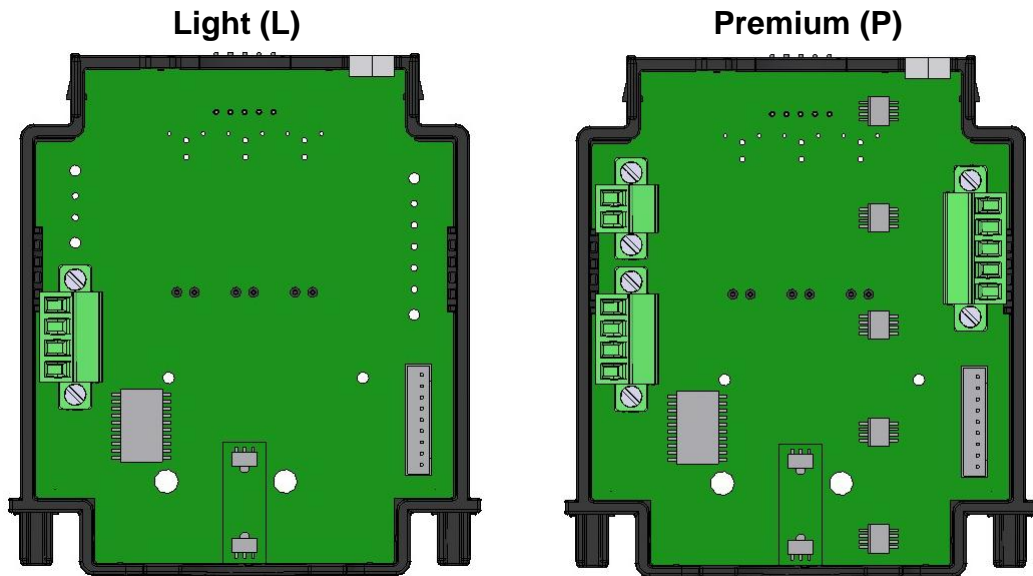

**Fig. 5**

#### 3.1 Electrical connections

Connector P 9. 1  
Connector P 9. 2  
Connector P 9. 3  
Connector P 9. 4

ASI +  
ASI -  
ASI +  
ASI -

#### 4-contacts connector

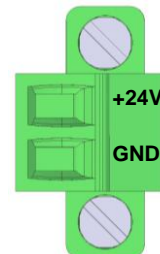

**Fig. 6**

#### 3.2 Electrical connections ES

Connector P 8 . 1 Voltage ES + 24V  
Connector P 8 . 2 Voltage ES GND

#### 2-contacts connector



**Fig. 7**

### 3.3 Electrical connections cycle stroke

- Connector P 2 . 1 external sensors + 24V
- Connector P 2 . 2 external sensor 1
- Connector P 2 . 3 external sensor 2
- Connector P 2 . 4 external sensors GND
- Connector P 2 . 5 external sensors GND

### 5-contacts connector



Fig. 8

### 3.4 Electrical connection external ASI 4-contacts connector

- |   |                  |       |
|---|------------------|-------|
| 1 | ASI + Bus signal | brown |
| 2 | - 24 V ES supply | white |
| 3 | ASI – Bus signal | blue  |
| 4 | + 24 V ES supply | black |

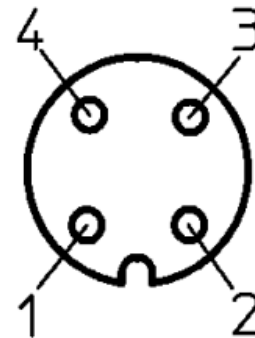

### 3.5 Electrical connection external inputs 5-contacts socket

- |   |                |                |
|---|----------------|----------------|
| 1 | L + Sensor 24V | brown          |
| 2 | Data input     | white          |
| 3 | L – Sensor GND | blue           |
| 4 | Data input     | black          |
| 5 | nc             | green / yellow |

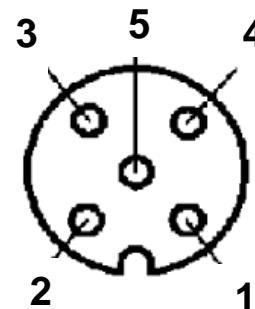

### 3.6 Technical data

#### Asi Bus Electronics

Supply voltage	30V DC Asi power pack
Supply voltage range	± 10%
Current consumption max.	80 mA (30V DC)
Current consumption at rest	23 mA
Current consumption at rest with top LED	46 mA
Ambient temperature	-10°C – +60°C
Protection class	IP 67 DIN EN 60529
with stainless steel hood	DIN EN 61140 I
with plastic hood	DIN EN 61140 I

#### Control air requirements to DIN ISO 8573-1:2001

Particle size	max. 5 µm
Particle density	max. 5mg / m <sup>3</sup> class 3
Water content	Dew point 2°C class 3
Oil content	oil-free
	max. 25mg / m <sup>3</sup> class 3
Air pressure	6 - 8 bar
Air volume	160 l / min / 6bar

### 4 Dimensions and mounting

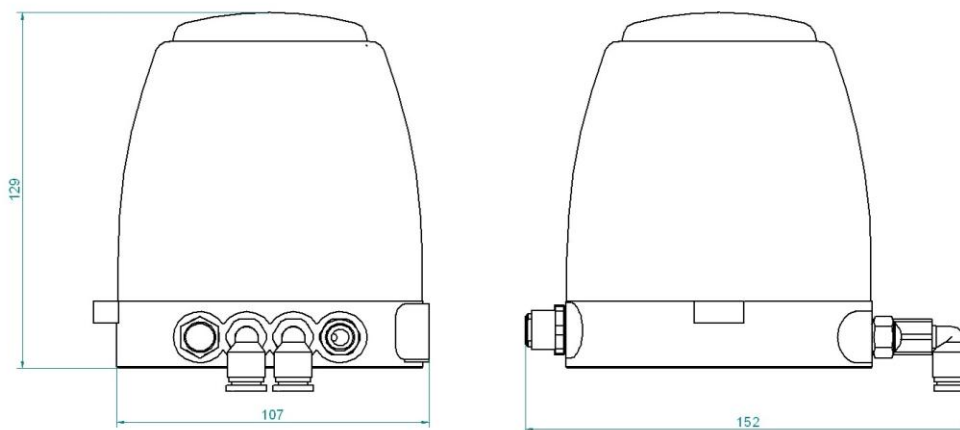

**Fig. 9**

pneumatic connections	G1/8
pneumatic hose	Ø 6 mm
electric connections	ASI cable adapter
	M12 adapter M16x1
	4 or 5 contacts connector

## 5 Setting of magnetic encoder of lift valves

Double-seat leakage valves (e.g.: 5670...)

$$A = 46,5^{+0,5}$$

$$B = 51,0^{-0,5} + \text{stroke}_{\text{measurable}} \quad \text{or}$$

$$B = 51,0^{-0,5} + (\text{stroke}_{\text{theor}} - \text{Leakage space})$$

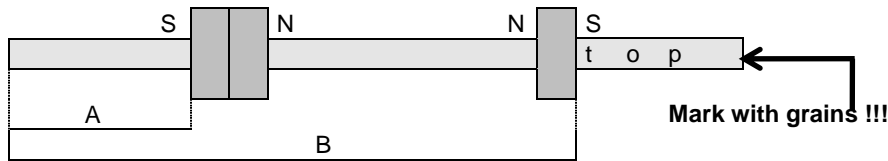

Nominal width	Stroke	Leakage space	(Cycle stroke)	A <sup>+0,5</sup>	B <sup>-0,5</sup>	Springs	Position indication
DN 25	21,8	2,5	5,0	46,5	70,5	1	5620.025.005-K000
DN 40	28,0	2,5	5,0	46,5	76,5	1	5620.040.005-K000
DN 50	34,0	2,5	5,0	46,5	82,5	2	5620.050.005-K000
DN 65	43,0	2,5	5,0	46,5	91,5	2	5620.065.005-K000
DN 80	51,5	3,5	6,0	46,5	99,0	2	5620.080.005-K000
DN 100	61,5	3,5	6,0	46,5	109,0	3	5620.100.005-K000
DN 125 /150	65,0	3,5	6,0	56,5	122,5	3	5620.150.005-K000

Corner valve (e.g.: 5536...)

$$A = 43,5^{+0,5}$$

$$B = 51,0^{-0,5} + \text{stroke}_{\text{measurable}} \quad \text{and/or}$$

$$B = 51,0^{-0,5} + (\text{stroke}_{\text{theor}})$$

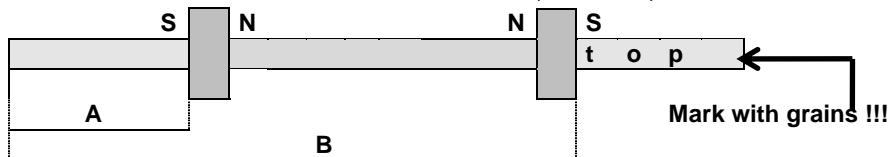

Nominal width	Stroke	A	B	Springs	Position indication
DN 25	22,0	43,5	73,0	2	5702.025.005-K000
DN 40 / 32	24,0	43,5	75,0	2	5702.040.005-K000
DN 50	26,0	43,5	77,0	2	5702.065.005-K000
DN 65	26,0	43,5	77,0	2	5702.065.005-K000
DN 80	35,0	43,5	86,0	2	5702.100.005-K000
DN 100	35,0	43,5	86,0	2	5702.100.005-K000

Reversing valve (e.g.: 5714...)

Nominal width	Stroke	A	B	Springs	Position indication
DN 25 / 32	18,5	43,5	69,5	1	5714.025.005-K000
DN 40	24,0	43,5	75,0	2	5702.040.005-K000
DN 50	26,0	43,5	77,0	2	5702.065.005-K000
DN 65	26,0	43,5	77,0	2	5702.065.005-K000
DN 80	35,0	43,5	86,0	2	5702.100.005-K000
DN 100	35,0	43,5	86,0	2	5702.100.005-K000

Aseptic valve (e.g.: 5836...)

Nominal width	Stroke	A	B	Springs	Position indication
DN 25	10,0	43,5	61,0	1	5802.025.005-K000
DN 40	12,0	43,5	63,0	1	5802.040.005-K000
DN 50	17,0	43,5	68,0	1	5802.050.005-K000
DN 65	21,0	43,5	72,0	1	5802.065.005-K000
DN 80	24,0	43,5	75,0	2	5702.040.005-K000
DN 100	29,0	43,5	80,0	2	5802.100.005-K000
DN 125	34,0	43,5	85,0	2	5802.125.005-K000
DN 150	40,0	43,5	91,0	2	5802.150.005-K000

www.sks-online.com

## 6 Symbols and references

### 6.1 Used symbols

#### Hazard notes



The warning triangle informs about special risks.



Hazard of hand injury

#### Warnings



Danger warning

#### Information



Observe operating instructions



Observe information

## 6.2 Used terms

ASI Bus	AS interface (Field bus system)
ES	<b>E</b> mergency <b>S</b> top
nu	not used

## 6.3 Safety requirements

The operator of the control head is obliged to train the operating personnel as well as the personnel authorized to carry out the maintenance. Everybody who works with controlling pneumatic actuators, must be informed about the dangers that these devices may present.

Persons being not listed as operating and maintenance personnel, are not allowed to stay in the operating range of the devices. The operator must see to the necessary measures to be taken.

As a general rule, the devices must be maintained solely by qualified personnel. Only original spare parts must be used. If OEM parts are used, warranty will be lost.

Every assembly work carried out at the control head is to be done in stressfree condition.

## 6.4 Dangers



The control heads are operated with 6 - 8 bar compressed air. Due to the design, stagnation pressure may arise in the cover of the control head in case of leakage.

Notification is hereby made that only original spare parts must be used for repair / maintenance. Damages which may result from the use of **OEM parts, won't be** accepted by the manufacturer.



The control head must be operated only in the ambiance intended for it.



The control head is fitted with a cover with bayonet catch. Make sure that no tools are used to loosen the cover and that the respective sense of rotation to open and/or close is observed.



When handling the control head, take into consideration that the hood may be under pressure. When removing it, make sure that the hood is held fast.



Only authorized persons are allowed to stay in the operational area of the control head.



If the pulse generator which is in the control head, is removed or put in, make sure that the closing cap is screwed down until the metallic stop. If the cap is



not completely screwed down, the cover may be destroyed through the stroke movement of the piston rod.

## 7 Mounting / Commissioning

### 7.1 Mounting of the control head

The control head is mounted on the actuator of the lift or turning valve respectively. The hexagon socket screws M6 with the fitted O-ring are required for mounting. If control heads with stainless steel hood are used, a spring is to be fitted for earthing according to fig. 6. In case of actuators whose diameter is smaller than 100 mm, a distance plate (item no. 5630600076-087) and an encoder lengthening piece (item no. 5630600077-059) are to be used.



**Fig. 10**



Before putting the control head into operation, always check that every part is fixed. In case the control heads are not correctly mounted, the operator himself will be liable.

### 7.2 Required tools for mounting and dismantling

1. Torx screwdriver size T20
2. Hexagon socket screw size 5
3. Screwdriver long blade size 3
4. Screwdriver size 2
5. Torx screwdriver size T10 only for Ki Top ATEX
6. Open-end wrench of width 13



### 7.3 Commissioning

After all screws had been tightened and the air pipe as well as the electrical connection had been made, the control head is ready for commissioning.

The air supply must be made according to specification. Check if the filter body is set into the air entry of the control head and if all O-rings are correctly mounted.

Prior to commissioning, the air pipe toward the control head must be blown off. Metallic impurities, welding residues and other solid bodies may destroy the control head.

### 7.4 Integration into a plant

If the control head is integrated into an automatically working plant, make sure that the function of the control head can be monitored. Monitoring must be guaranteed by the plant design. An optical control has also to be carried out in certain time intervals. The function control must be documented in case of optical inspection. If faults or damages are determined during control, they must be immediately removed.



Make sure with remote-controlled valves that the mediums won't be mixed if the fittings are operated by hand emergency actuation. In case of operation in automatically working plants the operators must familiarize with the cutoff or emergency stop of the plant respectively.

### 7.5 Mounting of the control head

When mounting the control head, make sure that the two O-rings are correctly mounted in the bottom part of the control head. Then mount the control head on a clean valve body, using 2 hexagon socket screws M 6 x 16 mm. If the control head is fitted with a stainless steel hood, an earthing spring must be built in according to fig. 10. The spring connects the stainless steel hood with the actuator body. The actuator itself must **not** be incorporated in an insulated way toward the potential EARTH. Always mind the equipotential bonding. After having mounted the bottom part of the control head, both the electrical connections and the control air are mounted at the head. After having put the electrical system into operation, the hood is put with the bayonet onto the bottom part and locked by turning it clockwise by approx. 15°.

The optional all around lamp can be installed by clipping on the control board.

## 7.6 Dismounting of the control head



Dismounting of the control head is made when the control head

1. shall be maintained or
2. when parts of the control head shall be replaced. Please observe the repair instructions.

The air supply to the control head is interrupted. The control head is disconnected from the electric contact. In order to dismount the control head, take the cover with both hands. To loosen the bayonet catch, turn it anticlockwise by approx. 15°. Now the cover can be lifted and removed. The electronics and/or the sensors including the pilot valve block can be dismounted with tool 1. The pilot valve block is differently assembled. The block is built in without assembly in case of control by external valves.

If, in addition to the control board and/or sensors, the bottom part shall be removed, too, all hose and electrical connections are to be loosened. The fixation of the bottom part which consists of 2 hexagon socket screws M6, is loosened with tool 2. Then the bottom part can be lifted and removed from the valve.

The optional all around lamp can be removed by using a screw driver size 2 and unfixing the lateral locking of the control board.

## 8 Spare and wear parts

Plastic hood	Spare part	5631.000.002-094
Stainless steel hood closed	Spare part	5631.000.110-032
Stainless steel hood display	Spare part	5631.000.110-032
O-ring kit	Spare part	5631.000.
Electric connection kit	Spare part	5631.000.
Pilot valve block 1MV DSV	Spare part	5630.001.013-000
Pilot valve block 2MV DSV To	Spare part	5630.002.013-000
Pilot valve block 2MV DSV	Spare part	5630.004.013-000
Pilot valve block 3MV DSV	Spare part	5630.003.013-000
Pilot valve block 1MV PDA	Spare part	5630.601.013-000
Pilot valve block 2MV PDA	Spare part	5630.602.013-000
ASI L control board	Spare part	5631.200.013-000
ASI P control board	Spare part	5631.200.012-000
Top LED display	Spare part	5631.000.018-000
Screw kit	Spare part	5631.000.
Magnetic encoder lift valves	Spare part	see chart item 5.0
Encoder flap	Spare part	5630.600.010-000

## 9 Transport

### 9.1 Delivery scope

The control head and a short description for the respective type are included with the delivery.



You can learn the options from the shipping documents.

### 9.2 Transport and packaging

Our products are very carefully produced, mounted and tested. Should there be any reason for complaint, we will naturally give you entire satisfaction within the scope of our warranty. We will be pleased to help you after expiry of warranty, too.



When receiving a delivery, always check the packing list against the delivery scope. After having noticed that delivery is complete, the goods must be checked for damage.

If there are damages, it is essential to note them down on the shipping documents. In case of damage, the forwarder must countersign the documents.

If parts are returned, either keep the outer package or use a packaging where the devices are not damaged.

## 10 Trouble-shooting

### 10.1 Emergency stop



In order to force an emergency stop of the control head, the operators of the plant must absolutely familiarize with the plant design. It is essential to train an emergency stop and to inform about the necessary elements regarding an emergency stop. The training of the persons who were charged with the operation of the plant, must be documented. Every damage to person and property which results from faulty operation or faulty application respectively, are borne by the plant operator.

## 11 Disposal

If the control head is put out of operation, the plastic parts are to be recycled. The electronic subassembly is recycled correspondingly for the recovery of raw materials.

You can dispose of these materials over the ways intended.



**ATTENTION!!** Make sure that there are not contaminations with materials from operation anymore. If so, the corresponding material for rinsing of the parts to be disposed, must be used.

**12 Annex 1**

**Alteration to forerunner model**

Removal of the printed circuit board guides from the bottom part of the control head

After having removed the pilot valve block including the fitted electronics, the printed circuit board guides are pulled out of the bottom part by means of flat pliers, if necessary.



The magnets on position A are dislocated upwards by 3 mm. This modification is very important in order to guarantee the recognition of the lower final position.

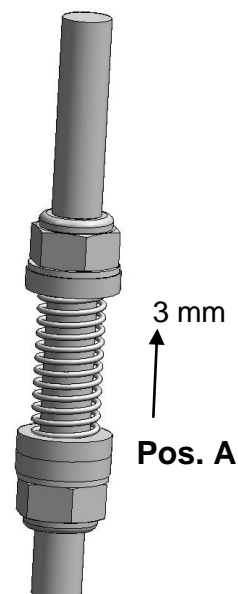

**12.1**     **Annex 2**  
Switching example

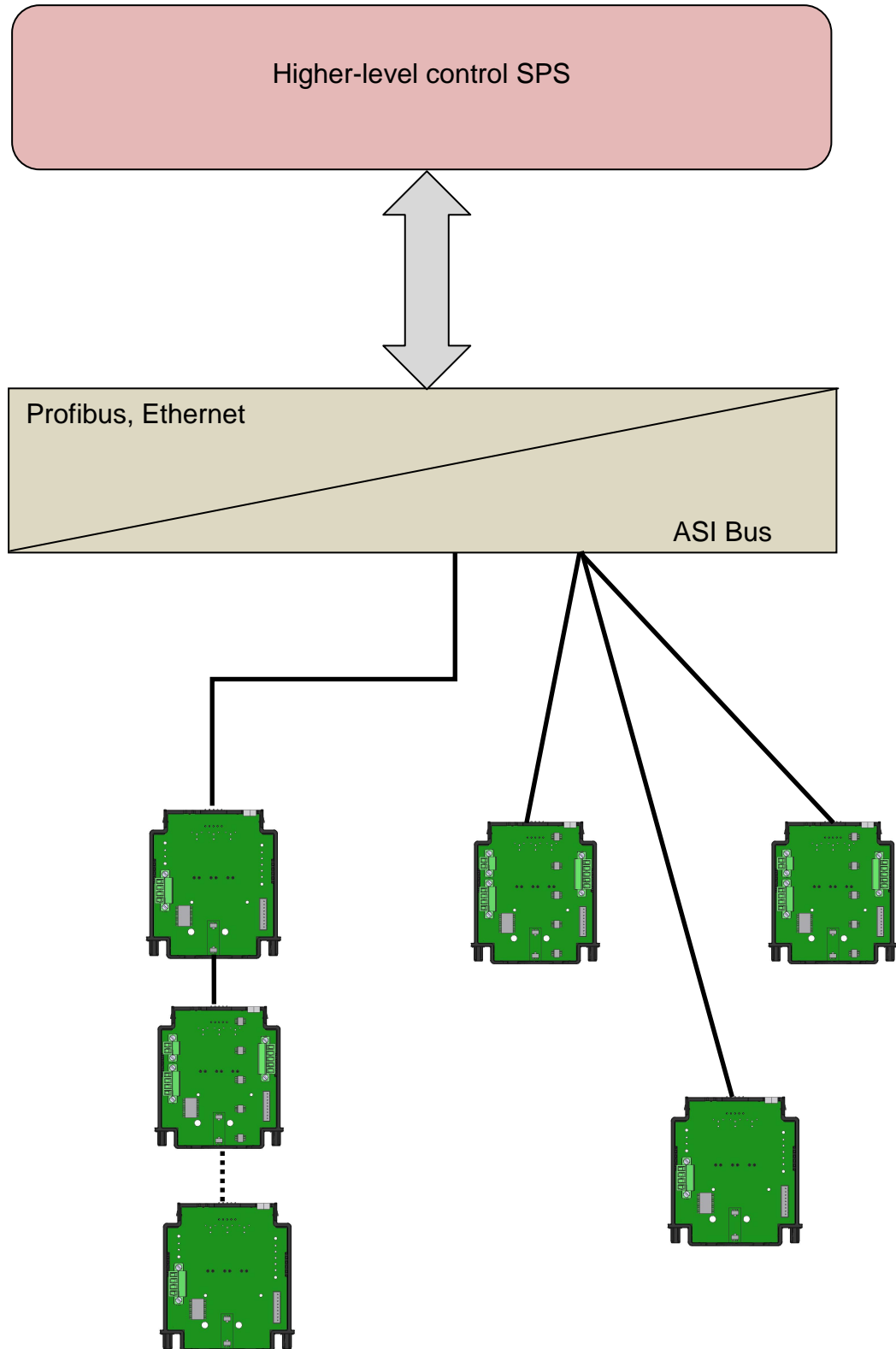

**control ASI VB**

	ASI signal				ASI signal			ASI signal			connector P2	
	A2	A1	A0	position	E1	E0	action	A3	A2	output signal for	Ext In1	Ext In0
<b>switch setting 0</b> double seat valve normal position closed with Seat Lift without Seat Lift detection	-	0	1	closed	0	0	close	0	-	external input 1	0	-
	-	0	1	upper Seat Lift	0	1	upper Seat Lift	1	-	external input 1	1	-
	-	0	1	lower Seat Lift	1	0	lower Seat Lift	-	0	external input 0	-	0
	-	1	0	opened	1	1	open	-	1	external input 0	-	1
<b>switch setting 1</b> double seat valve normal position closed without Seat Lift	-	0	1	closed	0	0	close	0	-	external input 1	0	-
								1	-	external input 1	1	-
								-	0	external input 0	-	0
	-	1	0	opened	1	1	open	-	1	external input 0	-	1
<b>switch setting 2</b> double seat valve normal position closed with only upper Seat Lift without Seat Lift detection	-	0	1	closed	0	0	close	0	-	external input 1	0	-
	-	0	1	upper Seat Lift	0	1	upper Seat Lift	1	-	external input 1	1	-
								-	0	external input 0	-	0
	-	1	0	opened	1	1	open	-	1	external input 0	-	1
<b>switch setting 3</b> double seat valve normal position closed with Seat Lift, with Seat Lift detection with Teach In	0	0	1	closed	0	0	close	0	-	external input 1	0	-
	0	1	1	upper Seat Lift	0	1	upper Seat Lift	1	-	external input 1	1	-
	1	0	1	lower Seat Lift	1	0	lower Seat Lift	-	-	not available	-	-
	0	1	0	opened	1	1	open	-	-	not available	-	-

**switch setting 4**

single seat valve  
normal position closed  
spring closing

A2	A1	A0	position	E1	E0	action	A3	A2	output signal for	Ext In1	Ext In0
-	0	1	closed	0	0	close	0	-	external input 1	0	-
							1	-	external input 1	1	-
							-	0	external input 0	-	0
-	1	0	opened	0	1	open	-	1	external input 0	-	1

**switch setting 5**

single seat valve  
normal position closed  
air opening / air closing

A2	A1	A0	position	E1	E0	action	A3	A2	output signal for	Ext In1	Ext In0
-	0	1	closed	0	0	close	0	-	external input 1	0	-
							1	-	external input 1	1	-
							-	0	external input 0	-	0
-	1	0	opened	0	1	open	-	1	external input 0	-	1

**switch setting 6**

single seat valve  
normal position open  
spring opening

A2	A1	A0	position	E1	E0	action	A3	A2	output signal for	Ext In1	Ext In0
-	0	1	closed	0	0	open	0	-	external input 1	0	-
							1	-	external input 1	1	-
							-	0	external input 0	-	0
-	1	0	opened	0	1	close	-	1	external input 0	-	1

**switch setting 7**

double seat valve  
normal position open  
with Seat Lift  
without Seat Lift detection

A2	A1	A0	position	E1	E0	action	A3	A2	output signal for	Ext In1	Ext In0
-	0	1	closed	0	0	open	0	-	external input 1	0	-
-	0	1	upper Seat Lift	0	1	upper Seat Lift	1	-	external input 1	1	-
-	0	1	lower Seat Lift	1	0	lower Seat Lift	-	0	external input 0	-	0
-	1	0	opened	1	1	close	-	1	external input 0	-	1

**switch setting 8**

butterfly valve

A2	A1	A0	position	E1	E0	action	A3	A2	output signal for	Ext In1	Ext In0
-	0	1	closed	0	0	close	0	-	external input 1	0	-



normal position closed  
spring closing

								1	-	external input 1		1	-
								-	0	external input 0		-	0
-	1	0	opened					-	1	external input 0		-	1

### switch setting 9

butterfly valve  
normal position closed  
air opening / air closing

A2	A1	A0	position	E1	E0	action	A3	A2	output signal for	Ext In1	Ext In0
-	0	1	closed	0	0	close	0	-	external input 1	0	-
							1	-	external input 1	1	-
							-	0	external input 0	-	0
-	1	0	opened	0	1	open	-	1	external input 0	-	1

### switch setting A

butterfly valve  
normal position open  
spring opening

A2	A1	A0	position	E1	E0	action	A3	A2	output signal for	Ext In1	Ext In0
-	0	1	closed	0	0	open	0	-	external input 1	0	-
							1	-	external input 1	1	-
							-	0	external input 0	-	0
-	1	0	opened	0	1	close	-	1	external input 0	-	1

### switch setting B

single seat valve  
normal position closed  
spring closing  
with Teach In

A2	A1	A0	position	E1	E0	action	A3	A2	output signal for	Ext In1	Ext In0
-	0	1	closed	0	0	close	0	-	external input 1	0	-
							1	-	external input 1	1	-
							-	0	external input 0	-	0
-	1	0	opened	0	1	open	-	1	external input 0	-	1

### switch setting C

single seat valve  
position undefined  
air opening / air closing

A2	A1	A0	position	E1	E0	action	A3	A2	output signal for	Ext In1	Ext In0
-	0	1	closed	1	0	open	0	-	external input 1	0	-
				0	0	-	1	-	external input 1	1	-
				1	1	-	-	0	external input 0	-	0
-	1	0	opened	0	1	close	-	1	external input 0	-	1

**switch setting D**

butterfly valve  
position undefined  
air opening / air closing

A2	A1	A0	position	E1	E0	action	A3	A2	output signal for	Ext In1	Ext In0
-	0	1	closed	1	0	close	0	-	external input 1	0	-
				0	0	-	1	-	external input 1	1	-
				1	1	-	-	0	external input 0	-	0
-	1	0	opened	0	1	open	-	1	external input 0	-	1

**switch setting E**

single seat valve  
normal position open  
spring opening  
with Teach In

A2	A1	A0	position	E1	E0	action	A3	A2	output signal for	Ext In1	Ext In0
-	0	1	closed	0	0	open	0	-	external input 1	0	-
							1	-	external input 1	1	-
							-	0	external input 0	-	0
-	1	0	opened	0	1	close	-	1	external input 0	-	1

**switch setting F**

factory-provided reserved

A2	A1	A0	position	E1	E0	action
-	-	-	internal use	-	-	internal use

**Attention !!!!!**

\* **only with Premium Type available**

E2 not used at all Control Heads

Ext In0 / Ext In1 only usable with Premium Type

**control ASI special VB**

	ASI signal			position	ASI signal			action	ASI signal			connector P2	
	A2	A1	A0		E1	E0	A3		A2	output signal for	Ext In1	Ext In0	
<b>switch setting 0</b> single seat tank outlet-valve with only upper Seat Lift with Teach In	0	0	1	main closed	0	0	without incentive	0	-	external input 1	0	-	
	0	1	0	main opened	0	1	main drive	1	-	external input 1	1	-	
	1	0	0	upper Seat Lift	1	0	upper Seat Lift	-	-	not available	-	-	
					1	1	without incentive	-	-	not available	-	-	
<b>switch setting 1</b> hub valve air opening / air closing separately controllable with Teach In	-	1	0	closed	0	0	without incentive	0	-	external input 1	0	-	
	-	0	1	opened	0	1	main drive open	1	-	external input 1	1	-	
					1	0	main drive close	-	0	external input 0	-	0	
								-	1	external input 0	-	1	
<b>switch setting 2</b> double sealing single seat right angle valve with leakage valve	-	0	1	main closed	0	0	without incentive	0	-	external input 1	0	-	
	-	1	0	main opened	0	1	main drive	1	-	external input 1	1	-	
	-	0	1	main closed	1	0	leakage drive	-	0	external input 0	-	0	
	-	1	0	main opened	1	1	main and leakage drive	-	1	external input 0	-	1	
<b>switch setting 3</b>	A2	A1	A0	Position	E1	E0	Action	A3	A2		Ext In1	Ext In0	
<b>switch setting 4</b>	A2	A1	A0	Position	E1	E0	Action	A3	A2		Ext In1	Ext In0	

**switch setting 5**

A2	A1	A0	Position

E1	E0	Action

A3	A2	

Ext In1	Ext In0

**switch setting 6**

A2	A1	A0	Position

E1	E0	Action

A3	A2	

Ext In1	Ext In0

**switch setting 7**

A2	A1	A0	Position

E1	E0	Action

A3	A2	

Ext In1	Ext In0

**switch setting 8**

A2	A1	A0	Position

E1	E0	Action

A3	A2	

Ext In1	Ext In0

**switch setting 9**

A2	A1	A0	Position

E1	E0	Action

A3	A2	

Ext In1	Ext In0

**switch setting A**

A2	A1	A0	Position

E1	E0	Action

A3	A2	

Ext In1	Ext In0

**switch setting B**

A2	A1	A0	Position

E1	E0	Action

A3	A2	

Ext In1	Ext In0

**switch setting C**

A2	A1	A0	Position

E1	E0	Action

A3	A2	

Ext In1	Ext In0

**switch setting D**

A2	A1	A0	Position

E1	E0	Action

A3	A2	

Ext In1	Ext In0

**switch setting E**

A2	A1	A0	Position	E1	E0	Action	A3	A2	Ext In1	Ext In0

**switch setting F**

factory-provided reserved

A2	A1	A0	Position	E1	E0	Action
			internal use			internal use

**Attention !!!!!**

E2 not used at all Control Heads

Ext In0 / Ext In1 only usable with Premium Type