

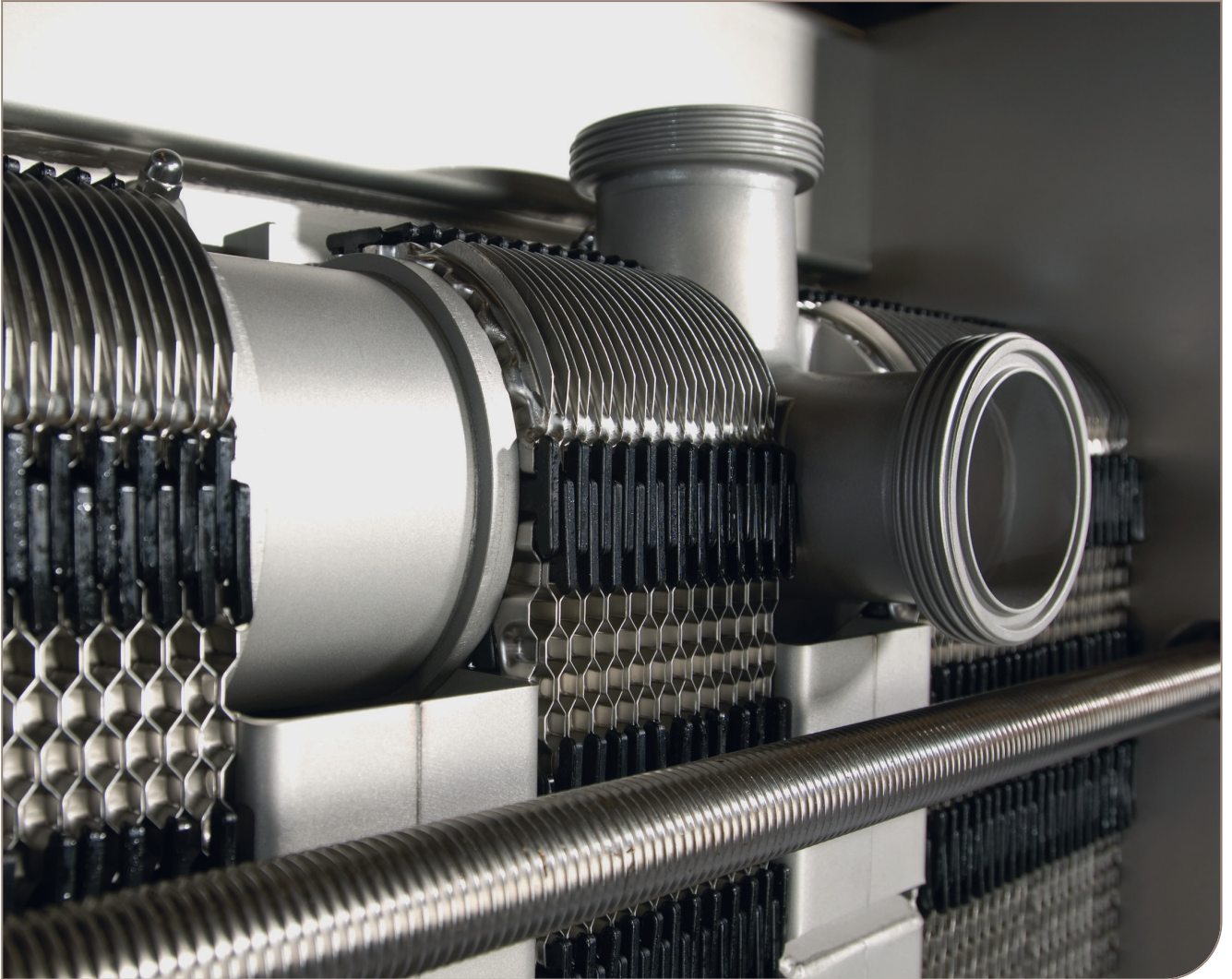

## Gasketed plate heat exchangers

FrontLine™ ClipLine®



Instruction Manual

Lit. Code 200000420-4-EN-GB



[www.sksonline.com](http://www.sksonline.com)

**Published by**  
Alfa Laval Lund AB  
Box 74  
Visit: Rudeboksvägen 1  
226 55 Lund, Sweden  
+46 46 36 65 00  
+46 46 30 50 90  
info@alfalaval.com

**The original instructions are in English**

**© Alfa Laval Corporate AB 2020-03**

This document and its contents are subject to copyrights and other intellectual property rights owned by Alfa Laval Corporate AB. No part of this document may be copied, re-produced or transmitted in any form or by any means, or for any purpose, without Alfa Laval Corporate AB's prior express written permission. Information and services provided in this document are made as a benefit and service to the user, and no representations or warranties are made about the accuracy or suitability of this information and these services for any purpose. All rights are reserved.



### English

Download local language versions of this instruction manual from [www.alfalaval.com/gphe-manuals](http://www.alfalaval.com/gphe-manuals) or use the QR code

### български

Изтеглете версиите на това ръководство за употреба на местния език от [www.alfalaval.com/gphe-manuals](http://www.alfalaval.com/gphe-manuals) или използвайте QR кода.

### Český

Stáhněte si místní jazykovou verzi tohoto návodu k obsluze z [www.alfalaval.com/gphe-manuals](http://www.alfalaval.com/gphe-manuals) nebo použijte QR kód.

### Dansk

Hent lokale sprogversioner af denne brugervejledning på [www.alfalaval.com/gphe-manuals](http://www.alfalaval.com/gphe-manuals) eller brug QR-koden.

### Deutsch

Sie können die landessprachlichen Versionen dieses Handbuch von der Website [www.alfalaval.com/gphe-manuals](http://www.alfalaval.com/gphe-manuals) oder über den QR-Code herunterladen.

### ελληνικά

Πραγματοποιήστε λήψη εκδόσεων του παρόντος εγχειριδίου οδηγιών σε τοπική γλώσσα από το [www.alfalaval.com/gphe-manuals](http://www.alfalaval.com/gphe-manuals) ή χρησιμοποιήστε τον κωδικό QR.

### Español

Descárguese la versión de este Manual de instrucciones en su idioma local desde [www.alfalaval.com/gphe-manuals](http://www.alfalaval.com/gphe-manuals) o utilice el código QR.

### Eesti

Selle kasutusjuhendi kohaliku keele versiooni saate alla laadida lingilt [www.alfalaval.com/gphe-manuals](http://www.alfalaval.com/gphe-manuals) või kasutades QR-koodi.

### Suomalainen

Laitaa tämän käyttöohjeen suomenkielinen versio osoitteesta [www.alfalaval.com/gphe-manuals](http://www.alfalaval.com/gphe-manuals) tai QR-koodilla.

### Français

Téléchargez des versions de ce manuel d'instructions en différentes langues sur [www.alfalaval.com/gphe-manuals](http://www.alfalaval.com/gphe-manuals) ou utilisez le code QR.

### Hrvatski

Preuzmite lokalne verzije jezika ovog korisničkog priručnika na poveznici [www.alfalaval.com/gphe-manuals](http://www.alfalaval.com/gphe-manuals) ili upotrijebite QR kod.

### Magyar

Az Ön nyelvére lefordított használati útmutatót letöltheti a [www.alfalaval.com/gphe-manuals](http://www.alfalaval.com/gphe-manuals) weboldáról, vagy használja a QR-kódot.

### Italiano

Scarica la versione in lingua locale del manuale di istruzioni da [www.alfalaval.com/gphe-manuals](http://www.alfalaval.com/gphe-manuals) oppure utilizza il codice QR.

### 日本の

[www.alfalaval.com/gphe-manuals](http://www.alfalaval.com/gphe-manuals) からご自分の言語の取扱説明書をダウンロードするか、QRコードをお使いください。

### 한국의

[www.alfalaval.com/gphe-manuals](http://www.alfalaval.com/gphe-manuals) 에서 이 사용 설명서의 해당 언어 버전을 다운로드하거나 QR 코드를 사용하십시오.

### Lietuvos

Lejupielādējiet šīs rokasgrāmatas lokālo valodu versijas no vietnes [www.alfalaval.com/gphe-manuals](http://www.alfalaval.com/gphe-manuals) vai izmantojiet QR kodu.

### Latvijas

Atsīsiņskite šios instrukcijas versijas vietos kalba iš [www.alfalaval.com/gphe-manuals](http://www.alfalaval.com/gphe-manuals) arba pasinaudokite QR kodu.

### Nederlands

Download de lokale taalversies van de instructiehandleiding vanaf [www.alfalaval.com/gphe-manuals](http://www.alfalaval.com/gphe-manuals) of gebruik de QR-code.

### Norsk

Last ned denne instruksjonshåndboken på lokalt språk fra [www.alfalaval.com/gphe-manuals](http://www.alfalaval.com/gphe-manuals) eller bruk QR-koden.

### Polski

Pobierz lokalne wersje językowe tej instrukcji obsługi z [www.alfalaval.com/gphe-manuals](http://www.alfalaval.com/gphe-manuals) lub użyj kodu QR.

### Português

Descarregue as versões locais na sua língua deste manual de instruções a partir de [www.alfalaval.com/gphe-manuals](http://www.alfalaval.com/gphe-manuals) ou use o código QR.

### Português do Brasil

Faça download das versões deste manual de instruções no idioma local em [www.alfalaval.com/gphe-manuals](http://www.alfalaval.com/gphe-manuals) ou use o código QR.

### Românesc

Versiunile în limba locală ale acestui manual de instrucțiuni pot fi descărcate de pe [www.alfalaval.com/gphe-manuals](http://www.alfalaval.com/gphe-manuals) sau puteți utiliza codul QR.

### **Русский**

Руководство пользователя на другом языке вы можете загрузить по ссылке [www.alfalaval.com/gphe-manuals](http://www.alfalaval.com/gphe-manuals) или отсканировав QR-код.

### **Slovenski**

Prenesite različice uporabniškega priročnika v svojem jeziku s spletne strani [www.alfalaval.com/gphe-manuals](http://www.alfalaval.com/gphe-manuals) ali uporabite kodo QR.

### **Slovenský**

Miestne jazykové verzie tohto návodu na používanie si stiahnite z [www.alfalaval.com/gphe-manuals](http://www.alfalaval.com/gphe-manuals) alebo použite QR kód.

### **Svenska**

Ladda ned lokala språkversioner av denna bruksanvisning från [www.alfalaval.com/gphe-manuals](http://www.alfalaval.com/gphe-manuals) eller använd QR-koden.

### **中国**

从 [www.alfalaval.com/gphe-manuals](http://www.alfalaval.com/gphe-manuals) 或使用 QR 扫描此使用说明书的本地语言版本。

---

# Contents

---

<b>1</b>	<b>Introduction</b> .....	<b>7</b>
1.1	Intended use.....	7
1.2	Reasonably foreseeable misuses.....	7
1.3	Prior knowledge.....	7
1.4	Delivered technical information.....	8
1.5	Warranty conditions.....	8
1.6	Advice.....	8
1.7	Environmental compliance.....	9
<b>2</b>	<b>Safety</b> .....	<b>11</b>
2.1	Safety considerations.....	11
2.2	Definitions of expressions.....	11
2.3	Personal protective equipment.....	12
2.4	Working at height.....	13
<b>3</b>	<b>Description</b> .....	<b>15</b>
3.1	Components.....	15
3.2	Name plate.....	17
3.3	A measure.....	19
3.4	Function.....	20
3.5	Multi-section.....	21
3.6	Multi-pass.....	22
3.7	Identification of plate side.....	22
<b>4</b>	<b>Installation</b> .....	<b>23</b>
4.1	Before installation, lifting and transport.....	23
4.2	Requirements.....	25
4.3	Crate handling.....	27
4.3.1	Crate — Inspection.....	28
4.3.2	Lifting and transportation.....	28
4.4	Unpacking the crate.....	30
4.4.1	Manufactured sides — Opening.....	31
4.4.2	Flip box — Opening.....	32
4.4.3	Crafted sides — Opening.....	33
4.4.4	Inspection after uncrating.....	34
4.5	Lifting the equipment.....	35
4.6	Raising.....	40
4.7	Assemble stands.....	42
4.8	Inspection before installation.....	43

<b>5</b>	<b>Operation</b> .....	<b>45</b>
5.1	Start-up.....	45
5.2	Unit in operation.....	47
5.3	Shut-down.....	47
<b>6</b>	<b>Maintenance</b> .....	<b>49</b>
6.1	Cleaning – Product side.....	50
6.2	Cleaning – Non-product side.....	53
6.3	Opening.....	55
6.3.1	Bolt configuration.....	55
6.3.2	Opening procedure.....	55
6.4	Manual cleaning of opened units.....	59
6.4.1	Deposits removable with water and brush.....	59
6.4.2	Deposits not removable with water and brush.....	60
6.5	Closing.....	61
6.6	Pressure test after maintenance.....	64
6.7	Regasketing.....	65
6.7.1	Clip-on / ClipGrip.....	65
<b>7</b>	<b>Storage of the plate heat exchanger</b> .....	<b>67</b>
7.1	Storage in crate.....	67
7.2	Taken out of service.....	68

# 1 Introduction

---

This manual provides information needed to install, operate and carry out maintenance of your gasketed plate heat exchangers.

The following models are covered in this manual:

- Clip 3
- Front 6
- Front 8
- Front 10
- Front 15

## 1.1 Intended use

The intended use of this equipment is to transfer heat in accordance with a decided configuration.

All other use is prohibited. Alfa Laval will not be held responsible for injury or damage if the equipment is used for any other purpose than the intended use described above.

## 1.2 Reasonably foreseeable misuses

- Do not lift or transport the crate nor the equipment in any other way than stated in this instruction manual.
- Connect a pipe in the way it is meant to be connected to the plate heat exchanger. Gasket and lining can be damaged if a pipe is connected in the wrong way.
- On semi-welded units it is a safety issue if the wrong pipe is connected to the wrong port, double check that the correct media is connected to the correct port according to the PHE drawings.
- It is a risk to damage the hangers if you hang in or move many plates at a time. It is recommended to handle one or a few plates at a time.
- When setting the **A** measure, always tighten the bolts crosswise, evenly, and a little at a time to avoid diagonal shifting and snaking. For information regarding the **A** measure, see Section [A measure](#) in the Chapter [Description](#).
- After a stop, increase the flow gently to avoid deformed plates.
- At a start, raise the temperature gently to avoid cracks in the gaskets or create a blow-out.

## 1.3 Prior knowledge

The plate heat exchanger shall be operated by persons who have studied the instructions in this manual and have knowledge of the process. This includes knowledge of precautions regarding media type, pressures, temperatures in the plate heat exchanger as well as specific precautions required by the process.

Maintenance and installation of the plate heat exchanger shall be done by persons who have knowledge and authorization according to local regulations. This may include actions such as piping, welding and other kind of maintenance.

For maintenance actions not described in this manual, contact your Alfa Laval representative for advice.

## 1.4 Delivered technical information

For the manual to be considered complete, the following delivered documentation must be accessible to the users of this instructions manual:

- **Declaration of Conformity**
- **Spare parts list**  
A bill of material as the equipment is built.
- **Plate hanging list**  
A description of the channel plate installation.
- **Technical specification**  
Connection information, measurements, and section information.
- **Plate heat exchanger (PHE) drawing**  
A drawing of the delivered plate heat exchanger.

The weight of the delivered plate heat exchanger as well as all dimensions can be found on the delivered PHE drawing.

The listed documents are unique for the delivered product (equipment serial number). Instructions shall be accompanied, where appropriate, by the technical documents, drawings and diagrams necessary for a full understanding of these instructions.

The PHE drawing mentioned in this manual are the drawings included in the delivery.

## 1.5 Warranty conditions

The warranty conditions are usually included in the signed sales contract prior to the order of the delivered plate heat exchanger. Alternatively, the warranty conditions are included in the sales offer documentation or with a reference to the document specifying the valid conditions. If faults occur during the specified warranty period, always consult your local Alfa Laval representative for advice.

Report to the local Alfa Laval representative, the date when the plate heat exchanger was put into operation .

## 1.6 Advice

Always consult your local Alfa Laval representative for advice on:

- New plate pack dimensions if you intend to change the number of plates
- Selection of gasket material if operating temperatures and pressures are permanently changed, or if another medium is to be processed in the plate heat exchanger



## 1.7 Environmental compliance

Alfa Laval endeavours to perform its own operations as cleanly and efficiently as possible, and to take environmental aspects into consideration when developing, designing, manufacturing, servicing and marketing its products.

### **Waste management**

Separate, recycle, or dispose of all material and components in a safe, and environmentally responsible way, or according to national legislation or local regulations. If there is any uncertainty regarding what material a component is made of, contact the local Alfa Laval sales company. Use a certified (ISO 14001 or similar) scrapping or waste handling company.

### **Unpacking**

Packing material consists of wood, plastics, cardboard boxes and, in some cases, metal straps.

- Wood and cardboard boxes can be reused, recycled or used for energy recovery.
- Plastics should be recycled or burnt at a licensed waste incineration plant.
- Metal straps should be sent for material recycling.

### **Maintenance**

- All metal parts should be sent for material recycling.
- Oil and all non-metal wear parts must be taken care of in accordance with local regulations.

### **Scrapping**

At end of use, the equipment shall be recycled according to relevant, local regulations. Besides the equipment itself, any hazardous residues from the process liquid must be considered and dealt with in a proper manner. When in doubt, or in the absence of local regulations, please contact the local Alfa Laval sales company.



# 2 Safety



## 2.1 Safety considerations

The plate heat exchanger shall be used and maintained in accordance with Alfa Laval's instructions in this manual. Incorrect handling of the plate heat exchanger may result in serious consequences with injuries to persons and/or property damage. Alfa Laval will not accept responsibility for any damage or injury resulting from not following the instructions in this manual.

The plate heat exchanger should be used in accordance with the specified configuration of material, media types, temperatures and pressure for your specific plate heat exchanger

## 2.2 Definitions of expressions

### **WARNING** Type of hazard

WARNING indicates a potentially hazardous situation which, if not avoided, could result in death or serious injury.

### **CAUTION** Type of hazard

CAUTION indicates a potentially hazardous situation which, if not avoided, may result in minor or moderate injury.

### **NOTE**

NOTE indicates a potentially hazardous situation which, if not avoided, may result in property damage.

## 2.3 Personal protective equipment

### Protective shoes

A shoe with a reinforced toe cap to minimize foot injuries caused by dropped articles.



### Protective helmet

Any helmet designed to protect the head from accidental injury.



### Protective goggles

A pair of tight-fitting eyeglasses worn to protect the eyes from hazards.



### Protective gloves

Gloves that protects the hand from hazards.



Safety

## 2.4 Working at height

If the installation requires working at a height of two meters or higher, safety arrangements must be taken in consideration.



### **WARNING** Risk of falling.

For any kind of work at height, always ensure that safe means of access is available and used. Follow local work at height regulations and guidelines. Use scaffolds or a mobile work platform and a safety harness. Create a safety perimeter around the working area and secure tools or other objects from falling.



Safety



Safety

# 3 Description

## 3.1 Components

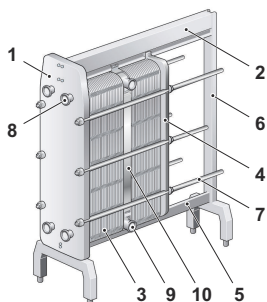

### Main components

#### 1. Frame plate

Fixed plate with a various number of portholes for the connection of the piping system. The carrying and guiding bar are attached to the frame plate.

#### 2. Carrying bar

Carries the plate pack and the pressure plate

#### 3. Plate pack

Heat is transferred from one media to the other through the plates. The plate pack consists of channel plates, end plates, gaskets and in some cases transition plates.

#### 4. Pressure plate

Moveable plate that can contain a various number of portholes for the connection of the piping system.

#### 5. Guiding bar

Keeps the channel plates, connection plates and the pressure plate aligned at their lower end

#### 6. Support column

Supports carrying and guiding bars.

#### 7. Tightening bolts

Compress the plate pack between the frame plate and the pressure plate. Remaining bolts are used as locking bolts.

#### 8. Sanitary connections

Pipes with sanitary fittings or flanges allow the media to enter into or exit from the plate heat exchanger.

## 9. Corner connections

Pipes with sanitary fittings or flanges allow the media to enter into or exit from the plate heat exchanger.

## 10. Connection plate

A plate with corner connections for the connection of the piping system. A connection plate divides the plate package into sections allowing two or more heat transfer processes in one plate heat exchanger. A plate heat exchanger can have several connection plates.

### Multi-section and multi-pass

- **Connection plate**

Plate used to separate two or more services in one plate heat exchanger. The plate pack performing such a service is called a section.

- **Corners**

The connection plates can be configured by selecting different corner connections such as single, double, pass-through or blind.

- **Partition plates**

Solid stainless steel plates used in multi-pass configurations. Supports the unholed ports of a turning plate.

- **Section**

When using connection plates, the plate heat exchanger will contain several sections (plate packs).

### Optional components

- **Foot**

Adjustable feet.

- **Protection sheets**

Cover the plate pack and protect against leakage of hot or aggressive fluids and the hot plate pack.

- **Bolt protection**

Plastic or stainless steel tubes that protect the threads of the tightening bolts.



## 3.2 Name plate

The type of unit, manufacturing number and manufacturing year can be found on the name plate. Pressure vessel details in accordance with the applicable pressure vessel code are also given. The name plate is fixed to the frame plate, most commonly, or the pressure plate. The name plate can be a steel plate or a sticker label.

 **WARNING Risk of damage to equipment.**

The design pressures and temperatures for each unit are marked on the name plate. These must not be exceeded.

 **CAUTION Risk of damage to equipment.**

Avoid aggressive chemicals for cleaning the plate heat exchanger when a sticker label is used.

The design pressure (11) and the design temperature (10), as given on the name plate, are the values against which the plate heat exchanger is approved according to the pressure vessel code in question. The design temperature (10) may exceed the maximum operating temperature (8) for which the gaskets have been selected for. If the operating temperatures as specified on the PHE drawing are to be changed the supplier should be consulted.

1. Space for logotype
2. Open space
3. Website for service
4. Drawing of possible locations of connections/Location of 3A tag for 3A units
5. Space for mark of approval
6. Warning, read manual
7. Date of pressure test
8. Maximum operating temperature
9. Manufacturer test pressure (PT)
10. Allowable temperatures Min/Max (TS)
11. Allowable pressures Min/Max (PS)
12. Decisive volume or volume for each fluid (V)
13. Locations of the connections for each fluid
14. Decisive fluid group
15. Year of manufacture
16. Serial number
17. Type
18. Manufacturer's name

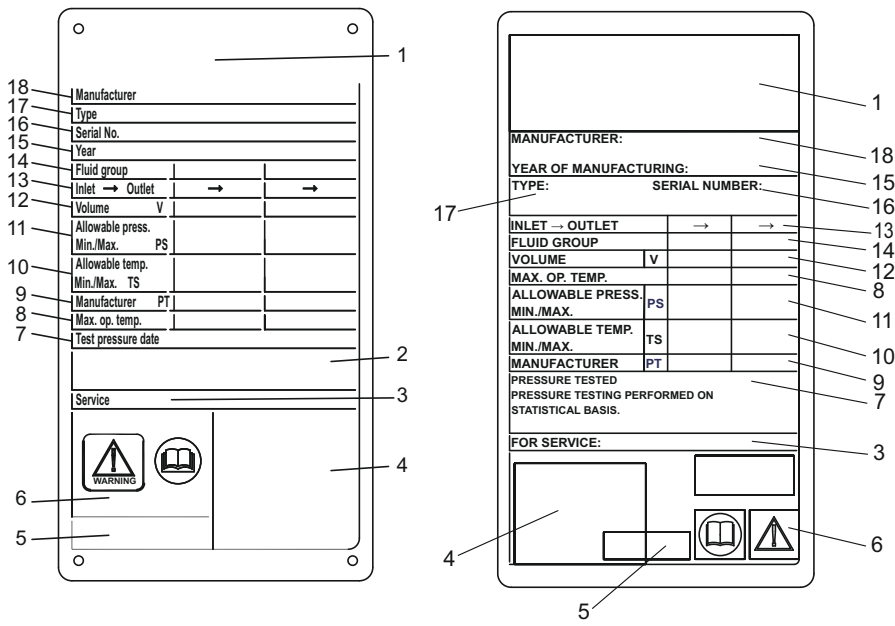
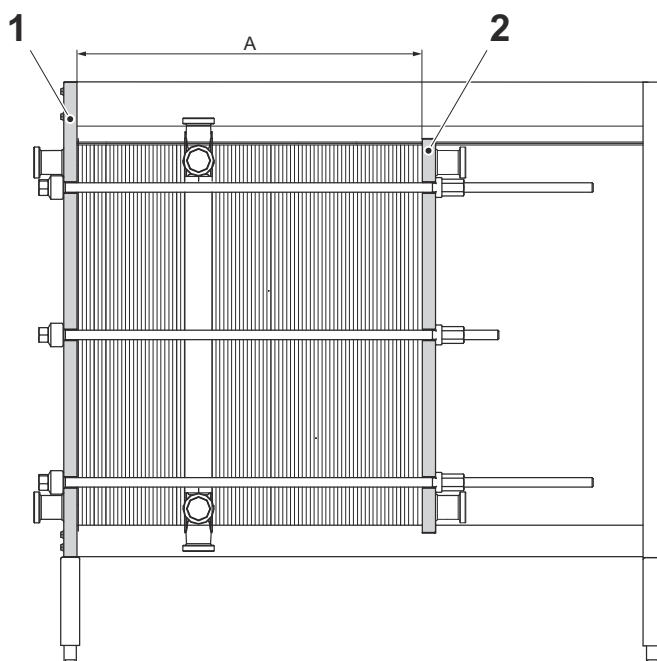

Figure 1: Example of metallic name plate to the left and sticker label name plate to the right

### 3.3 A measure

The **A** measure is the distance from the frame plate (1) to the pressure plate (2).



## 3.4 Function

The plate heat exchanger consists of a pack of corrugated metal plates with portholes for the input and output of the two separate fluids. The heat transfer between the two fluids takes place through the plates.

The plate pack is assembled between a frame plate and a pressure plate and compressed by tightening bolts. The plates are fitted with a gasket which seals the channel and directs the fluids into alternate channels. The plate corrugation promotes fluid turbulence and supports the plates against differential pressure.

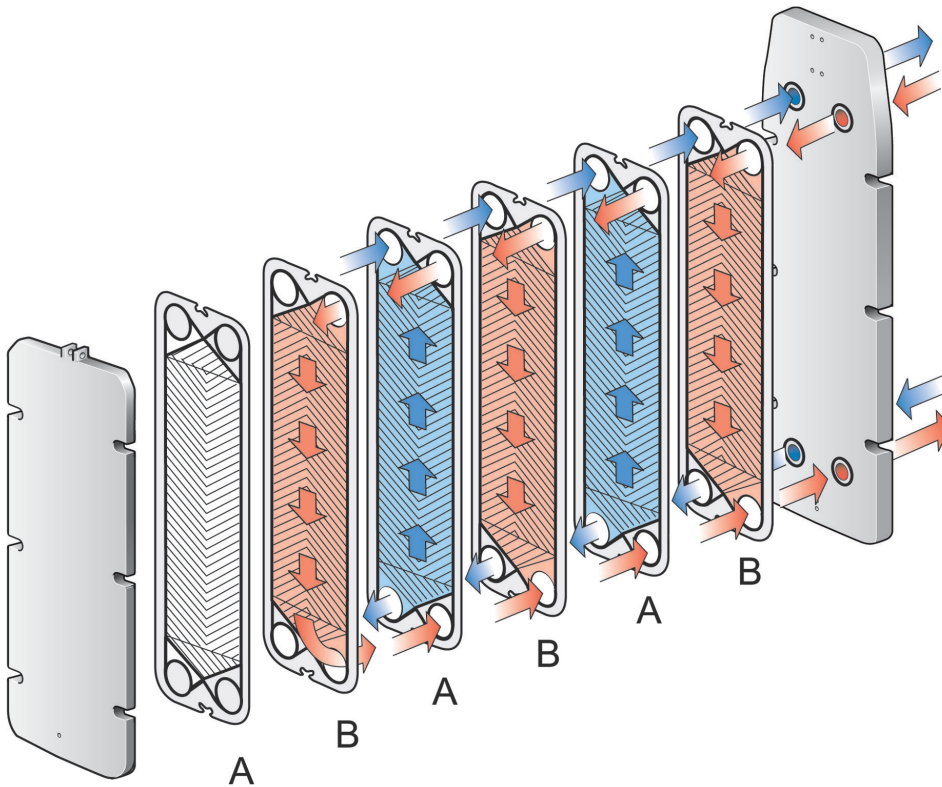
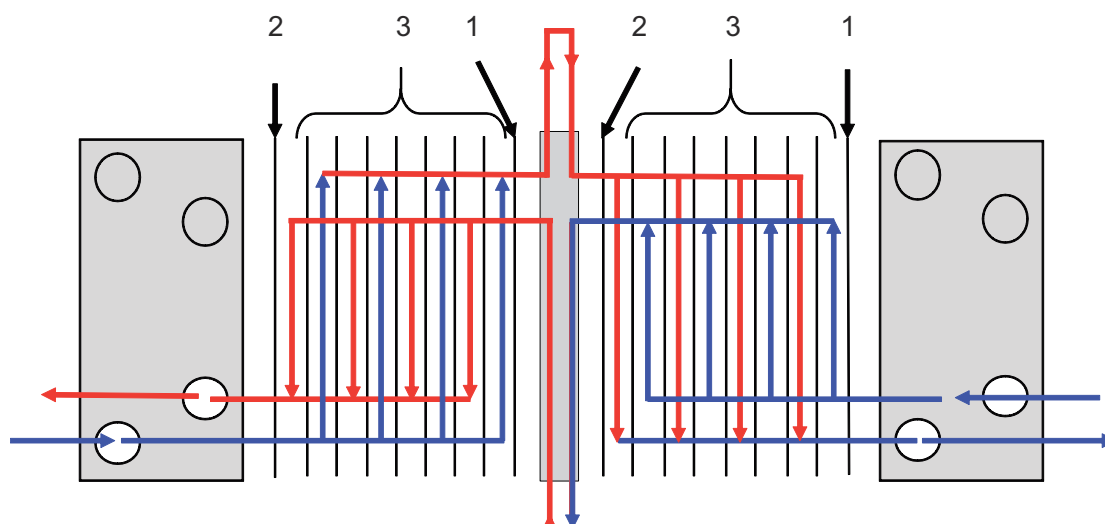

Figure 2: Principle of plate pack arrangement, gaskets facing the pressure plate.

## 3.5 Multi-section

A multi-section plate heat exchanger can be set up by using connection plates. An example of multi-section configuration is when a media needs to be heated in one stage and then cooled down in the next stage.

Each of the connection plates can be configured by selecting different corner connections such as single, double, pass-through or blind.



**Figure 3: Example of a multi-section set up.**

1. End plate I
2. End plate II
3. Channel plates

## 3.6 Multi-pass

Multi-pass sections can be created by using turning plates with 1, 2 or 3 unholed ports. The main purpose is to change the flow direction of one or both fluids.

An example of where multi-pass can be used is in processes that require longer heating periods if the media requires slower heating.

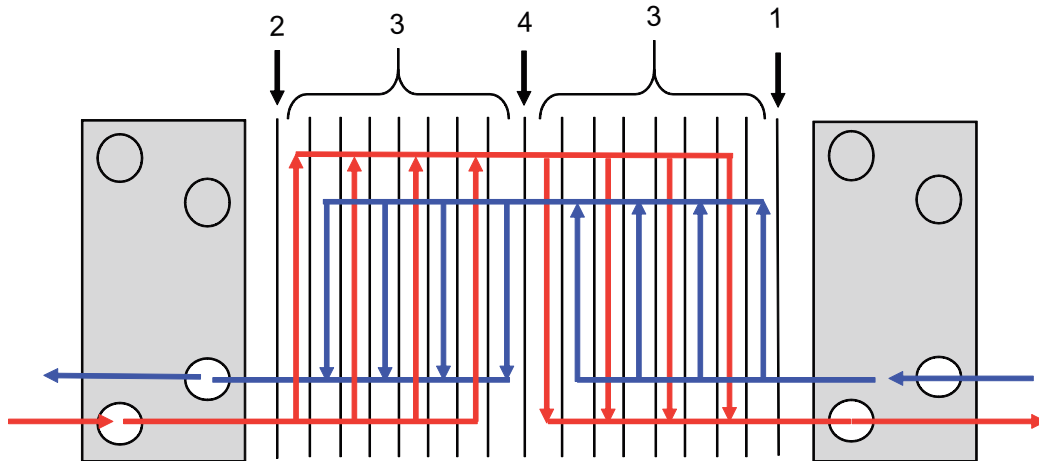
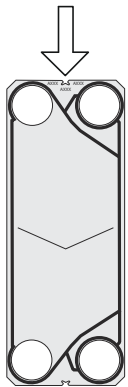

**Figure 4: Example of a multi-pass set up.**

1. End plate I
2. End plate II
3. Channel plates
4. Turning plate

## 3.7 Identification of plate side

The A side of the plates (symmetric pattern) are identified by a stamp with the letter A and the model name at the top of the plate (see the image below)



# 4 Installation

## 4.1 Before installation, lifting and transport

 **CAUTION** Risk of damage to equipment.

During installation or maintenance, precautions must be taken to avoid damaging the plate heat exchanger and its components. Damage to components can adversely affect the performance or serviceability of the plate heat exchanger.

 **WARNING** Risk of personal injury.

The equipment is heavy.  
Never lift or move the equipment manually.

### To consider before installation

- Keep the plate heat exchanger packed until installation.
- Before connecting any piping, make sure all foreign objects have been flushed out of the piping system that should be connected to the plate heat exchanger.
- Before start-up, check that all the tightening bolts are firmly tightened and that the plate pack has the correct measurements. See the PHE drawing.
- When connecting the piping system, make sure the pipes do not subject the plate heat exchanger to stress or strain.
- Avoid vibration, install any anti-vibration equipment if necessary.
- The plate heat exchanger connections on the follower and connector grids have little strength against pipe work or nozzle loads. Such loads can arise for example from thermal expansion. Proper care must be taken to avoid transfer of such pipe forces and moments to the plate heat exchanger.
- To avoid water hammer, do not use fast-closing valves.
- In automated installations, the stopping and starting of pumps and actuation of valves should be programmed so that the resulting amplitude and frequency of the pressure variation will be as low as possible.
- If pressure variance is expected, install efficient dampers.
- Make sure that no air remains inside the plate heat exchanger.
- Safety valves shall be installed according to current pressure vessel regulations.
- It is recommended that protection sheets are used to cover the plate pack. Protect against the leakage of hot or aggressive fluids and the hot plate pack.
- Design pressures and temperatures for each model are marked on the name plate. These shall not be exceeded.

- Follow the hierarchy specified in this presentation.
- Check the condition of the flooring.
- Always complete a risk assessment.
- Use frames and equipment designed for the task.
- Always check the center of gravity before unpacking or moving the equipment. Keep the center of gravity as low as possible.
- Always move slow and steady.

### **Risk assessment**

Always perform a thorough risk assessment before lifting and transporting the crated or uncrated equipment on every handling occasion.



## 4.2 Requirements

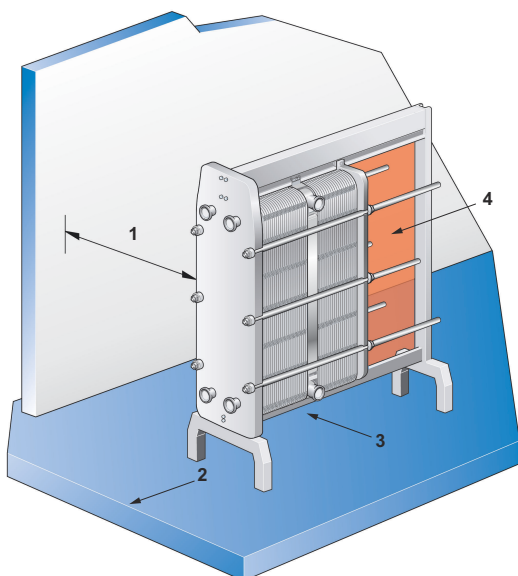

### Space

See the delivered PHE drawing for actual measurements.

1. Free space is required for lifting plates in and out.
2. Free space is required for removing the tightening bolts. The size is depending on the length of the tightening bolts.
3. Supports for the guiding bar may be needed.
4. Do not use fixed pipes or other fixed parts like feet, fasteners etc. inside the shaded area.

### Foundation

Install on a flat foundation designed for the equipment weight.

### Elbow

To make it easier to disconnect the plate heat exchanger, an elbow should be fitted to the connection in the pressure plate, directed upwards or sideways, and with another flange located just outside the contour of the plate heat exchanger.

### Shut-off valve

To be able to open the plate heat exchanger, shut-off valves should be provided in all connections.

### Connection

Avoid excessive force on pipe connections.

**CAUTION Risk of damage to equipment.**

Turning of the connections will damage the gaskets on the end plate and cause leakage.

Fit the pipes so that no tension is transferred to the plate heat exchanger. Nozzle loads are not permitted.

Pipes connected to the pressure plate and to the connection plates must allow  $\pm 1\%$  of the distance from the connection to the frame plate (see the assembly PHE drawing).

**Connections in the pressure plate**

It is important that the plate pack has been tightened to the correct **A** measure (check against the PHE drawing) before the piping system is connected.

If necessary, adjust the **A** measure.

**NOTE**

If the **A** measure has to be adjusted, remove the pipes from the pressure plate and the connections plate(s) so that the pressure plate and the connection plate(s) are free to move along the carrying bar.

**Applicable for 3A standards**

Once the unit is in position and the feet have been properly adjusted, it is the responsibility of the end user to seal around the feet with silicone or caulking to fulfil 3A standard.

**Required personnel**

The installation and handling of the plate heat exchanger requires at least two persons.

## 4.3 Crate handling

**⚠ WARNING Risk of personal injury.**





Lifting and transport of the crated and uncrated equipment must be carried out by skilled persons. See [Prior knowledge](#) in Chapter [Preface](#).

The plate heat exchanger is delivered on a pallet and can be packed in a crate or wrapped in stretch film. There are three main versions of crates:

- Manufactured sides — sides and a top made in separate pieces
- Flip box — a box with hinges in the sides and a loose top
- Crafted sides — sides and top crafted board by board when packed for delivery

The centre of gravity is marked on the crate or the wrapping.

A crate is also marked with other symbols according to the table.

Symbol	Meaning
	Centre of gravity
	Do not stack on top
	Fragile
	This way up

### 4.3.1 Crate — Inspection

Examine the outside of the crates before starting to unload and report any transport damage. Contact the insurance company in case of any damages.

### 4.3.2 Lifting and transportation

 **WARNING Risk of personal injury.**

The equipment is heavy and sensitive and must be handled with precaution.

Unauthorized personnel is not allowed to be in the defined risk area when the crated or uncrated equipment is handled.

 **WARNING Risk of damage to equipment.**

The crate is not designed to stand the force from hoist slings pressing on the top of the crate.

Always use a forklift to lift and transport the crated equipment.

 **WARNING Risk of personal injury.**

Never work under hanging load.

 **WARNING Risk of personal injury.**

Always use a forklift approved for the load and in accordance with local regulations.

Labels, symbols, and warning placards are located on the external surfaces of the crates and outline the handling principles which must be observed.

- Never leave a hanging load unattended.
- When the equipment, crated or uncrated, is assembled with the delivered pallet it must be lifted using a forklift.
- Plan the lifting and the transportation thoroughly.
- Define the risk area for lifting and transport of the crated or uncrated equipment.
- Always perform a risk assessment of the risk area and transport ways before lifting and transporting the crated or the uncrated equipment.
- The crates should not be subjected to sudden shocks or movement. The crates are not load bearing and must not be stacked or have other items placed on them.
- The crates should be kept in the indicated upright position.
- Lift the crates as instructed. Lift only enough to clear the floor.
- Lift and transport the load slowly and gently.
- Crated equipment must be lifted in the pallet using a forklift.

- The length of the forklift forks should be equal to, or longer than, the depth of the pallet.
- Make sure that the crate remains stable on the lifting equipment.
- Move the crate to its destination.
- Lower the crate gently to the floor, leaving enough room around it for easy access to all sides.
- Make sure that the crate is firmly supported. Place blocks or plates under it if required.
- When working under a hanging load, for example when assembling the stands, you must secure the load from falling on you using wooden beams or likewise.
- The centre of gravity must always be between the forklifts forks.

Labels that will indicate if the crates have been tipped over or exposed to extremes of humidity can be put on the crates or the equipment.

## 4.4 Unpacking the crate

Follow the procedure for the corresponding type of crate::

- Manufactured sides — See Procedure [Manufactured sides - Open](#)
- Flip box — See Procedure [Flip box - Opening](#)
- Crafted sides — See Procedure [Crafted sides - Opening](#)

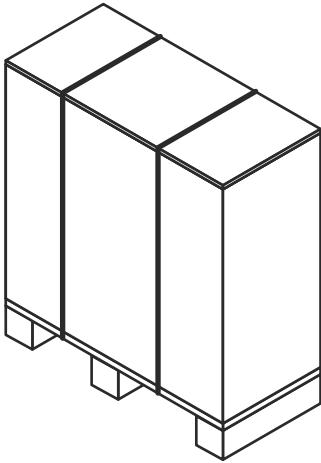

### Unpacking area

The minimum unpacking area must be at least twice the size of the largest crate.

When the crate is removed but the equipment is still assembled with the pallet, remove any loose parts or smaller parts assembled with the pallet.

Equipment can be assembled with the pallet with plastic bands or with screws. Plastic bands are cut off. Screws are removed.

#### 4.4.1 Manufactured sides — Opening

 **WARNING** Risk of personal injury.

The equipment or loose objects can fall. Plastic straps may snap when cut off. There can be sharp edges, splinters, and nails on the crate and the equipment.

Wear personal protective equipment when handling the equipment during unpacking and installation. Handle the equipment with precaution. See Section *Personal protective equipment* in Chapter *Safety*.

- 1 Cut the plastic bands off and remove the top of the crate.

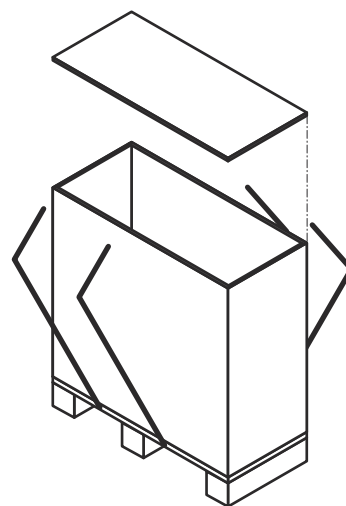

- 2 Disassemble the sides by removing the screws or the nails.

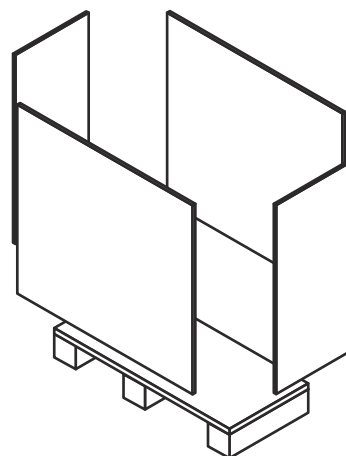

## 4.4.2 Flip box — Opening

**⚠ WARNING Risk of personal injury.**

The equipment or loose objects can fall. Plastic straps may snap when cut off. There can be sharp edges, splinters, and nails on the crate and the equipment.

Wear personal protective equipment when handling the equipment during unpacking and installation. Handle the equipment with precaution. See Section *Personal protective equipment* in Chapter *Safety*.

- 1 Cut the plastic bands off and remove the top of the crate.

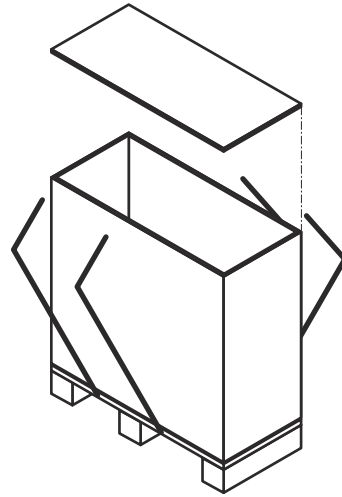

- 2 Lift the flipbox up and remove it from the pallet.

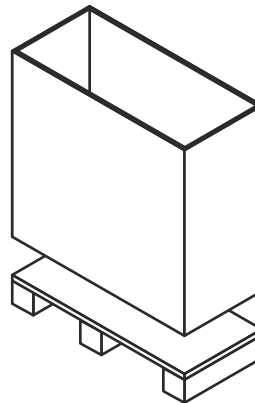



### 4.4.3 Crafted sides — Opening

**⚠ WARNING Risk of personal injury.**

The equipment or loose objects can fall. Plastic straps may snap when cut off. There can be sharp edges, splinters, and nails on the crate and the equipment.

Wear personal protective equipment when handling the equipment during unpacking and installation. Handle the equipment with precaution. See Section *Personal protective equipment* in Chapter *Safety*.

A crate with crafted sides and top is assembled with boards.

- 1 Cut off the plastic bands and remove them.

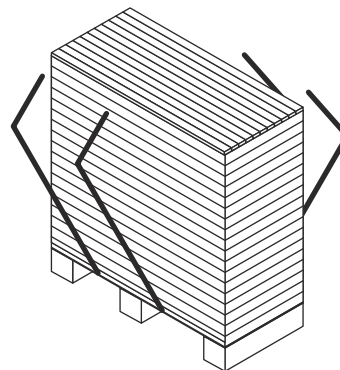

- 2 Start with the top of the crate and remove one board at a time.

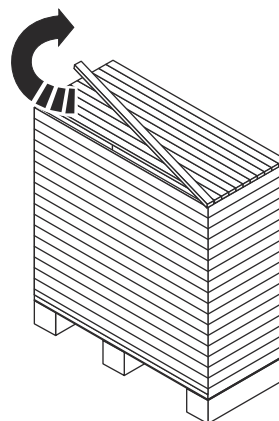

- 3 When the boards on the top are completely removed continue with the sides.

#### 4.4.4 Inspection after uncrating

When the equipment is placed in its intended location, always perform the inspections listed below:

- Check the **A** measure.
- Make sure that all bolts are properly tightened.
- Make sure that the stands and feet are properly tightened.

 **NOTE**

Some equipment is delivered with the stands disassembled.

- Check that connection piping can be removed to perform service.
- Make sure that there is enough space to remove plates on one side of the plate heat exchanger.

## 4.5 Lifting the equipment

It is recommended to engage the services of a rigging company to take care of all handling related matters until the equipment is in the position where it will be installed.

### **⚠ WARNING Risk of personal injury.**

Equipment is heavy with a centre of gravity placed high.

Lifting and transport of the crated and uncrated equipment must be carried out by skilled persons. See Section *Prior knowledge* in Chapter *Introduction*.

### **⚠ WARNING Risk of personal injury.**

The equipment or loose objects can fall. Plastic straps may snap when cut off. There can be sharp edges, splinters, and nails on the crate and the equipment.

Wear personal protective equipment when handling the equipment during unpacking and installation. Handle the equipment with precaution. See Section *Personal protective equipment* in Chapter *Safety*.

### **⚠ WARNING Risk of personal injury.**

Never work under hanging load.

### **⚠ WARNING Risk of personal injury.**

Never work alone during lifting and handling of the crated or uncrated equipment.

The authorized personnel are always responsible for the safety, correct selection of lifting equipment and execution of the lifting and raising procedures. Use undamaged hoist slings approved for the weight of the plate heat exchanger. Use the lifting points as illustrated. If the equipment has lifting eye bolts, these must be used.

If otherwise not stated, use two hoist slings (1) and (2) and make sure that the lifting angle ( $\alpha$ ) is between  $45^\circ$  and  $90^\circ$ .

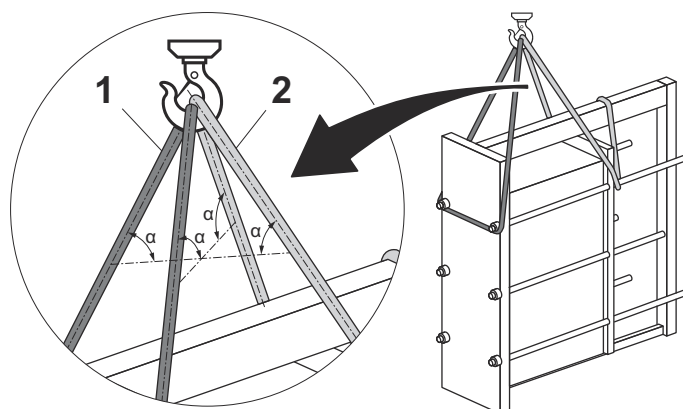

**Figure 5: The illustration shows the threading of the hoist slings.**

### Crated equipment

When the equipment is crated it must be lifted in the delivered pallet using a forklift.

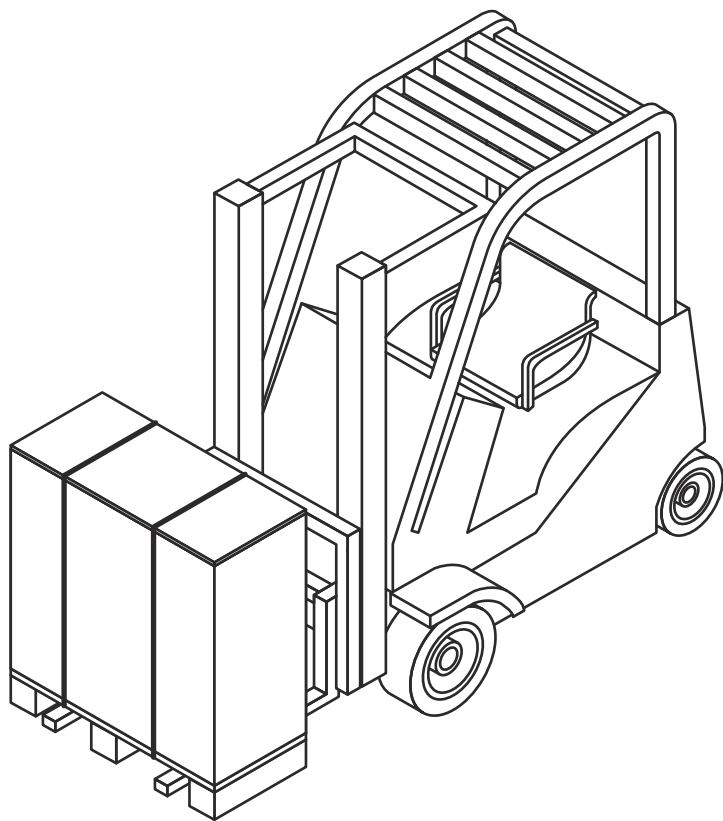

### Disassemble equipment from pallet

Uncrate the equipment according to Section [Installation - Unpacking the crate](#).

It is recommended to let the equipment remain assembled with the pallet and handle it using a forklift until it is time to install it.

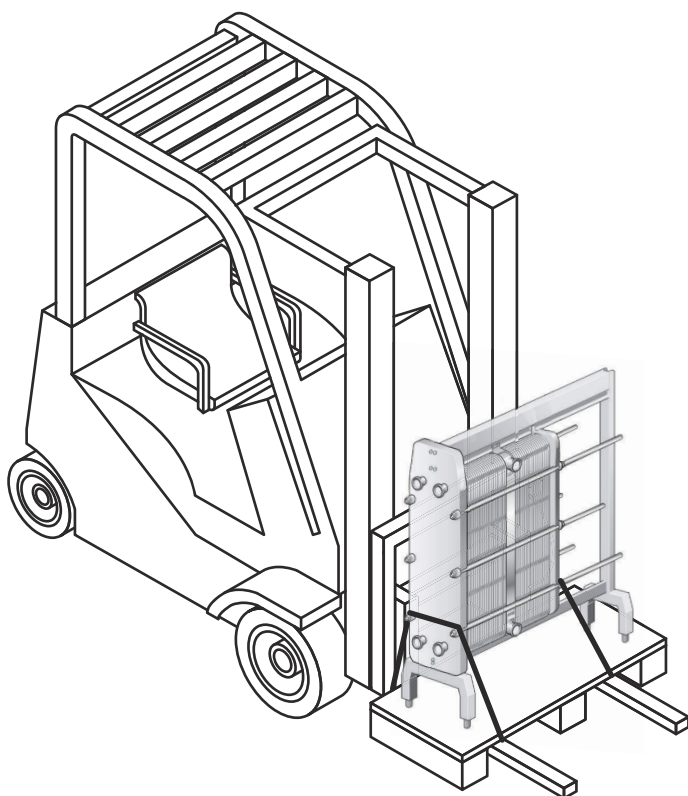

Before loosening the equipment from the pallet, secure the equipment from falling using hoist slings.

**! NOTE**

Do not lift up the equipment and the pallet. Only stretch the hoist slings so the equipment will not fall.

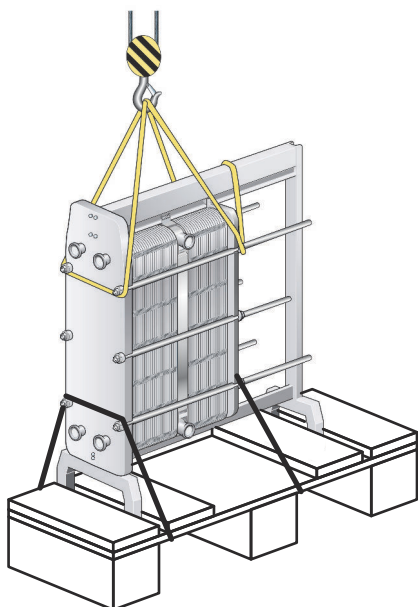

Remove any attachment that assembles the equipment with the pallet.

Gently lift up the equipment and make sure that it releases from the pallet.

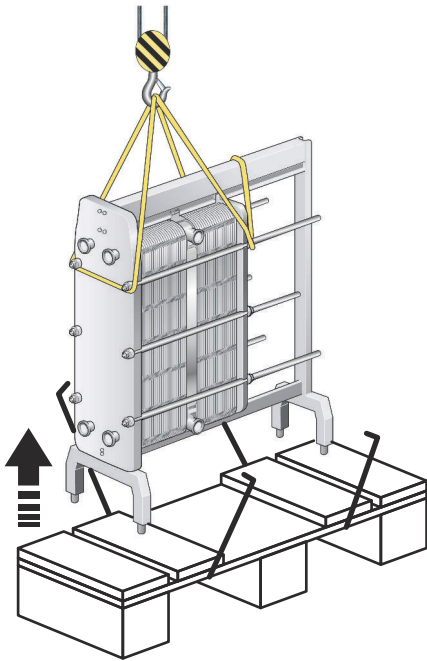

### Uncrated equipment

**⚠ CAUTION Risk of damage to equipment.**

For hoist slings or for lifting devices always use the attachment points marked with red rings in the below figures. Use of other attachment points or strap load directions than those described are not allowed. If the plate heat exchanger is not supplied with lifting devices from Alfa Laval, the corresponding equipment must be selected and the same attachment points must be used. The authorized personnel have full responsibility for selecting components and procedures in a safe and correct way. Always be careful during the lifting procedure to avoid damage to the plate heat exchanger components.

**⚠ WARNING Risk of damage to equipment.**

Never lift by the connections.

If the equipment is assembled with the delivered pallet, it must be lifted using a forklift.

If the equipment is disassembled from the delivered pallet, it must be lifted using hoist slings.

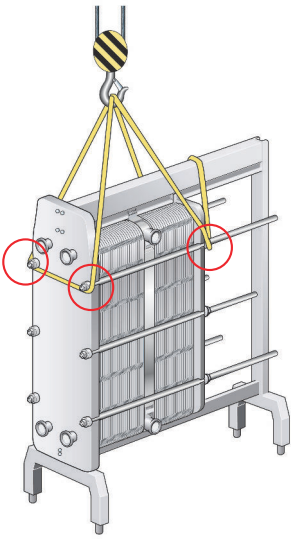

## 4.6 Raising

This instruction is valid when raising the plate heat exchanger after delivery from Alfa Laval. Only use a strap approved for the weight of the plate heat exchanger. Follow the principle of the instruction below.

**CAUTION** Risk of damage to equipment.

The hoist slings shall be long enough to be able to rotate the plate heat exchanger without obstruction. Consider especially the space for the support column. Always be careful during the raising procedure to avoid damage to the plate heat exchanger components.

- 1 Place two timber beams on the floor.

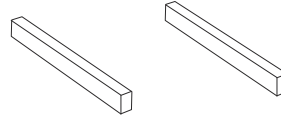

- 2 Lift the plate heat exchanger off the pallet using hoist slings.

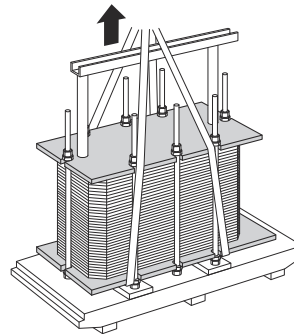

- 3 Place the plate heat exchanger on the timber beams.

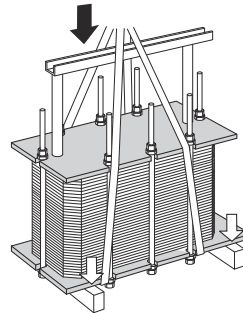

- 4 Place a hoist sling around one bolt on each side.

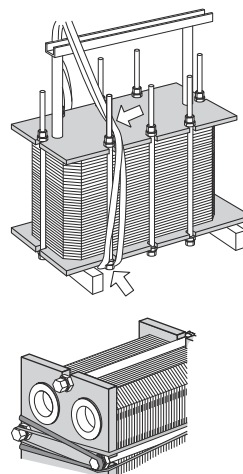



- 5 Lift the plate heat exchanger off the timber beams.

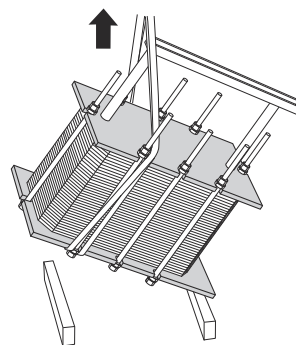

- 6 Lower the plate heat exchanger into a horizontal position and place it on the floor.

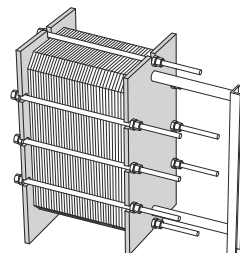

## 4.7 Assemble stands

Some models of plate heat exchangers are delivered without the stands assembled. Follow the instruction below.

**⚠ WARNING Risk of crushing.**

The equipment is heavy.

Be careful when handling the equipment. Do not reach in under equipment that is not secured.

**⚠ WARNING Risk of crushing.**

Never work under hanging load.

Always make safety arrangement to avoid crushing.

1 On delivery, cover plates are attached on the frame plate and support column in the same positions where the stands shall be assembled.

2 Lift up the equipment according to Section [Lifting](#)

3 Remove the screws, the washers, and the nuts and then remove the cover plates.

4 Use the same screws, washers and nuts to assemble the stands on the plate heat exchanger according to the picture.

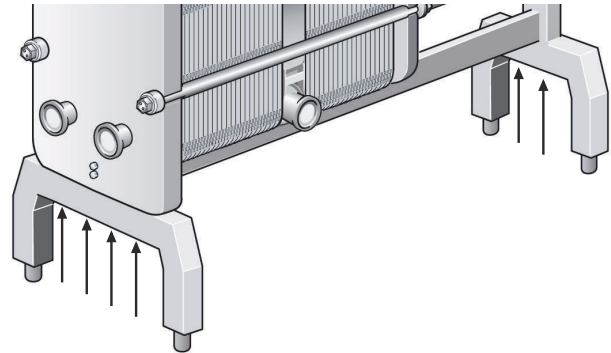

5 For Front 15 units two stabilising bars should also be assembled according to the picture.

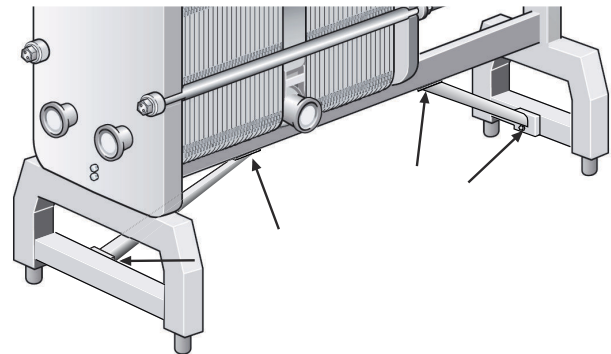

## 4.8 Inspection before installation

When the equipment is placed in its intended location, always perform the inspections listed below:

- Check the **A** measure.
- Make sure that all bolts are properly tightened.
- Make sure that the stands and feet are properly tightened.
- Check that connection piping can be removed to perform service.
- Make sure that there is enough space to remove plates on one side of the plate heat exchanger.



# 5 Operation

## 5.1 Start-up

During the start-up, check that there are no visible leakages from the plate pack, valves or piping system.

### ⚠ CAUTION

Before pressurizing the plate heat exchanger, it is important to ensure that the temperature of the plate heat exchanger is within the temperature range as stated on the name plate.

### ⚠ CAUTION Risk of leakage.

If the temperature of the plate heat exchanger is below the minimum temperature for the gaskets prior to the service, it is recommended to heat the plate heat exchanger above this limit to avoid cold leakage.

### ! NOTE

If several pumps are included in the system, make sure you know which one should be activated first.

Centrifugal pumps must be started with valves closed and the valves must be operated as smoothly as possible.

Do not run pumps temporarily empty on the suction side.

### ! NOTE

Adjustments of flow rates should be made slowly in order to avoid the risk of pressure surge (water hammer).

Water hammer is a short lasting pressure peak that can appear during the start-up or shut-down of a system, causing liquids to travel along a pipe as a wave at the speed of sound. This can cause considerable damage to the equipment.

- 1 Before start-up, check that all the tightening bolts are firmly tightened and that the **A** measure is correct. See the PHE drawing.

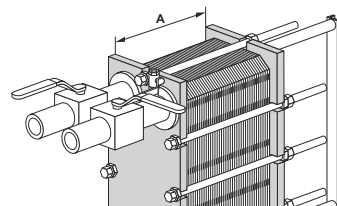

- 2 Check that the valve is closed between the pump and the unit controlling the system flow rate to avoid pressure surge.

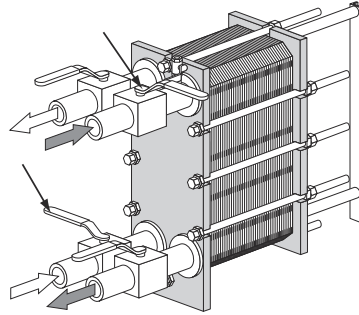

- 3 If there is a vent valve installed at the exit, make sure it is fully open.

- 4 Increase the flow rate slowly.

- 5 Open the air vent and start the pump.

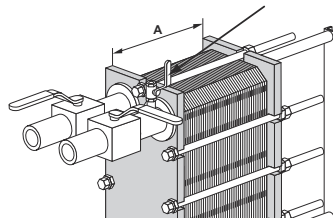

- 6 Open the valve slowly.

**! NOTE**

Avoid rapid temperature changes in the plate heat exchanger. With media temperatures over 100 °C, slowly increase the temperature, preferably at least for one hour.

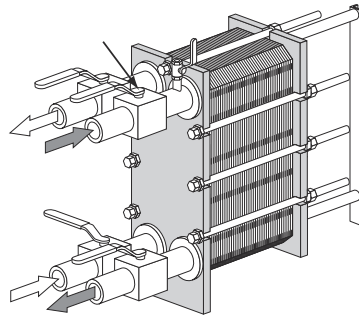

- 7 When all the air is expelled, close the air vent.

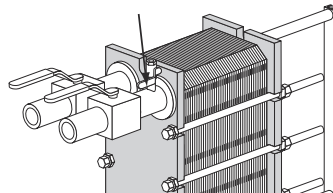

- 8 Repeat the procedure for the second media.

## 5.2 Unit in operation

Adjustments of flow rates should be made slowly in order to protect the system against sudden and extreme variations of temperature and pressure.

During operation, check that media temperatures and pressures are within the limits stated on the name plate and the PHE drawing.

### WARNING

In case of failures that endanger safety operation, turn off the flows to the plate heat exchanger in order to decrease the pressure.

## 5.3 Shut-down

### NOTE

If several pumps are included in the system, make sure you know which one should be stopped first.

- 1 Slowly close the valve controlling the flow rate of the pump you are about to stop.

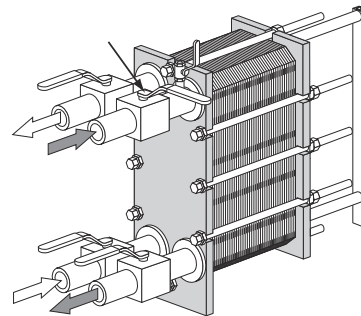

- 2 When the valve is closed, stop the pump.
- 3 Repeat the two steps for the other side for the second media. Continue with both sides of each section.

- 4 If the plate heat exchanger is shut down for several days or longer, it should be drained. Draining should also be done if the process is shut down and the ambient temperature is below the freezing temperature of the media. Depending on the media processed, it is also recommended to rinse and dry the plate heat exchanger plates and connections.

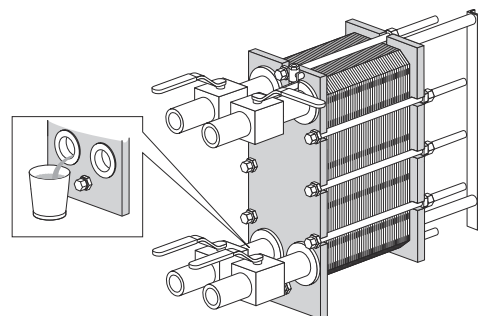

### NOTE

Avoid vacuum in the plate heat exchanger by opening vent valves.





## 6 Maintenance

---

To keep the plate heat exchanger in good condition, regular maintenance is required. It is recommended to record all maintenance of the plate heat exchanger.

The plates need to be cleaned on a regular basis. The frequency depends on several factors such as type of media and temperature.

Different methods can be used for cleaning (see procedure [Cleaning – Product side](#) on page 50 and [Cleaning – Non-product side](#) on page 53) or reconditioning can be performed at an Alfa Laval service center.

After a long period of use, it can be required to regasket the plate heat exchanger. See Procedure [Regasketing](#) on page 65.

Other maintenance that should be performed regularly:

- Keep carrying bar and guiding bar clean with paraffin oil.
- Keep the tightening bolts cleaned.
- The stainless steel surfaces of the frame plate, the pressure plate and connection plates are glass blasted. Clean with a cloth wetted by paraffin oil. Do not degrease the surface!
- Lubricate the threads of the tightening bolts with an EP (extreme pressure) grease. For example, use Gleitmo 800 or its equivalent.
- Grease the suspension wheels on the pressure plate and the connection plates.

## 6.1 Cleaning – Product side

Immediately after a production cycle, the product side is normally cleaned through the circulation of acid and/or lye as a built-in sequence in the production cycle.

### NOTE

After the first test run of the product, the plate heat exchanger should be cleaned following a cleaning program applicable to the product in question. The plate heat exchanger should then be opened, see Section [Opening](#) on page 55, and the plate surfaces carefully inspected. The cleaning results should be checked at regular intervals.

### WARNING Risk of personal injury.

Use proper protective equipment when using the cleaning agents. See Section [Personal protective equipment](#) in Chapter [Safety](#).

### WARNING

Corrosive cleaning liquids. Can cause serious injuries to skin and eyes.  
Use proper protective equipment. See Section [Personal protective equipment](#) in Chapter [Safety](#)

Sterilisation is performed immediately before starting the next production cycle. See Section [Sterilisation](#) on page 50

### Flow rates

The flow rate during the cleaning of the product side should always be at least the same as the production's flow rate. An increased flow rate may be required in some cases, for example in milk sterilisation and the processing of viscous liquids or liquids containing particles.

Recommended limits for cleaning solutions:

- 5% by volume AlfaCaus at max. 70°C
- 0.5% by weight acid solution at max. 70°C

For detailed information regarding cleaning and sterilisation contact an Alfa Laval representative.

### Sterilisation

The methods of sterilisation below are recommendations. Instructions for sterilisation can also be included in the documentation of the complete system delivered with the plate heat exchanger as one part.

Method	Instructions
By heat	Circulate water of 90°C until all parts of the system have been kept at the required temperature for at least ten minutes.
Chemically by hypochlorite	<p>Before introducing the hypochlorite solution, make sure that the equipment is clean, has cooled down and is free from deposits and that no acid residues are left.</p> <p>Gradually add 100 cm<sup>3</sup> of hypochlorite solution, containing max. 150 g/l of active chlorine to 100 l of circulating water at a max. temperature of 20°C.</p> <p>Treat for five minutes, up to maximum of 15 minutes. Rinse well after sterilisation.</p>

## Typical cleaning programs

Consult your local Alfa Laval representative for advice on suitable cleaning programmes.

**Table 1: Coolers**

Products rich in protein	
Daily	Weekly
Rinsing 5 min	Rinsing 5 min
Lye 20 min	Acid 15 min
Rinsing 10 min	Rinsing 5 min
Stop	Lye 20 min
Sterilisation 10 min	Rinsing 10 min
	Stop
	Sterilisation

**Table 2: Pasteurisers and other heaters**

Products rich in protein
Daily
Rinsing 5 min
Acid 15 min
Rinsing 5 min
Lye 20 min
Rinsing 5 min <sup>1</sup>
Acid 15 min <sup>2</sup>
Rinsing 10 min
Stop

<sup>1</sup> The need for an additional acid cycle in order to remove calcium carbonate scaling depends on the product. In many cases, it is possible to carry out cleaning at considerably longer intervals. Sometimes, it is possible to eliminate acid cleaning altogether.

<sup>2</sup> The need for an additional acid cycle in order to remove calcium carbonate scaling depends on the product. In many cases, it is possible to carry out cleaning at considerably longer intervals. Sometimes, it is possible to eliminate acid cleaning altogether.

**Table 3: High content of insoluble components, for example nectar and tomato juice**

Products poor in protein	
Daily	Weekly
Rinsing 10 min	Rinsing 10 min
Lye 30 min	Lye 30 min
Rinsing 10 min	Rinsing 5 min
Stop	Acid 15 min
Sterilisation 10 min	Rinsing 10 min
	Stop
	Sterilisation 10 min

Table 4: Low content of insoluble components, for example beer and wine

Products poor in protein	
Daily <sup>1</sup>	Weekly
Rinsing 5 min	Rinsing 5 min
Lye 15 min	Lye 15 min
Rinsing 10 min	Rinsing 5 min
Stop	Acid 15 min
Sterilisation 10 min	Rinsing 10 min
	Stop
	Sterilisation 10 min

<sup>1</sup> In some cases, where the risk of growth of microorganisms is low, it is possible to eliminate daily cleaning and replace it with the following procedure: Rinsing 20 min – Stop – Sterilisation 20 min.

### Applicable for 3A standards

When used in a processing system to be sterilised, the system shall be provided with an automatic shutdown if the product pressure becomes less than that of the atmosphere and not be restarted without resterilisation (see paragraph D10.3). The information plate will then state that the plate heat exchanger “is” designed for steam sterilisation.

## 6.2 Cleaning – Non-product side

The cleaning-in-place (CIP) equipment permits cleaning of the plate heat exchanger without opening it. The purpose of cleaning with CIP is as follows:

- Cleaning of fouling and descaling of lime deposits
- Passivation of cleaned surfaces to reduce susceptibility to corrosion
- Neutralization of cleaning liquids before draining

Follow the instructions of the CIP equipment.

**⚠ WARNING Risk of personal injury.**

Use proper personal protective equipment when using the cleaning agents. See Section *Personal protective equipment* in Chapter *Safety*.

**⚠ WARNING Risk of personal injury.**

Corrosive cleaning liquids. Can cause serious injuries to skin and eyes.

Use proper personal protective equipment. See Section *Personal protective equipment* in Chapter *Safety*.

### CIP equipment

Contact an Alfa Laval sales representative for the size of CIP equipment.

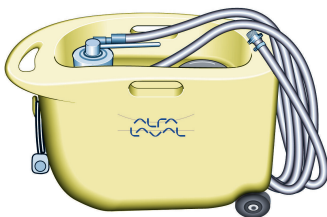

**⚠ WARNING Risk of personal injury.**

The residuals after a cleaning procedure shall be handled according to local environmental regulations. After neutralization most cleaning solutions may be drained into the waste water system under the condition that the fouling deposits do not contain heavy metals or other toxic or environmentally dangerous compounds. Prior to disposal, it is recommended to analyze the neutralized chemicals for any hazardous compounds that were removed from the system.

### Cleaning liquids

Liquid	Description
AlfaCaus	A strong alkaline liquid, for removing paint, fat, oil and biological deposits.
AlfaPhos	An acid cleaning liquid for removing metallic oxides, rust, lime and other inorganic scale. Contains repassivation inhibitor
AlfaNeutra	A strong alkaline liquid for neutralization of AlfaPhos before drainage.
Alfa P-Neutra	For neutralization of Alfa P-Scale.
Alfa P-Scale	An acidic powder cleaner for the removal of primary carbonate scale but also other inorganic scale.

Liquid	Description
AlfaDescalent	A non-hazardous acidic cleaning agent for the removal of inorganic scale.
AlfaDegreaser	A non-hazardous cleaning agent for the removal of oil, grease or wax deposits. Also prevents foaming when using Alpacon Descaler.
AlfaAdd	AlfaAdd is a neutral cleaning strengthener designed to be used with AlfaPhos, Alfa-Caus and Alfa P-Scale. 0.5–1 vol% is added to the total diluted cleaning solution to provide better cleaning results on oily and fatty surfaces and where biological growth occurs. AlfaAdd also reduces any foaming.

If CIP cannot be done, cleaning must be done manually. See Section [Manual cleaning of opened units](#) on page 59.

### Chlorine as a growth inhibitor

Chlorine, commonly used as a growth inhibitor in cooling water systems, reduces the corrosion resistance of stainless steels (including high alloys like Alloy 254).

Chlorine weakens the protection layer of these steels making them more susceptible to corrosion attacks than they otherwise would be. It is a matter of time of exposure and concentration.

In all cases where the chlorination of non-titanium equipment cannot be avoided, your local representative must be consulted.

Water of more than 330 ppm Cl ions may not be used in the preparation of cleaning solutions.

 **CAUTION** Risk of personal injury.

Ensure that the handling of residuals after using chlorines follow local environmental regulations.

 **NOTE**

Titanium is not affected by chlorine.

## 6.3 Opening

During manual cleaning, it is necessary to open the plate heat exchanger to clean the plates.

### NOTE

Before opening the plate heat exchanger, check the warranty conditions. If in any doubt, contact the Alfa Laval sales representative. See Section [Warranty conditions](#) in Chapter [Introduction](#).

### WARNING Risk of personal injury.

The plate heat exchanger can be hot.

Wait until the plate heat exchanger has cooled down to about 40 °C (104 °F).

### WARNING Risk of personal injury.

Use proper protective equipment. See Section [Personal protective equipment](#) in Chapter [Safety](#).

### 6.3.1 Bolt configuration

The bolt configuration of the plate heat exchanger varies between different models. The major force of the plate pack is held by the tightening bolts (TB). To distribute the force evenly over the frame plate and pressure plate, locking bolts (LB) are used as well. The locking bolts can be shorter and can have smaller dimensions. In the opening and closing procedure, it is important to identify the tightening bolts (TB) and the locking bolts (LB). See the illustration below.

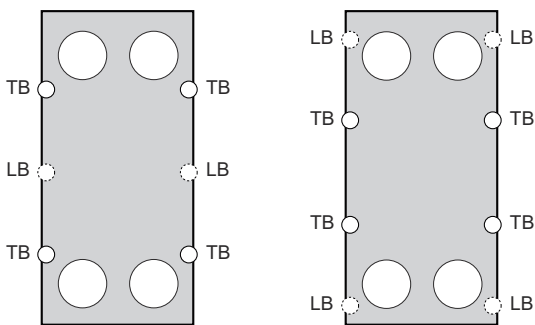

### 6.3.2 Opening procedure

- 1 Shut down the plate heat exchanger.

- 2 Close the valves and isolate the plate heat exchanger from the rest of the system.

**! NOTE**

The plate heat exchanger must be pressureless before disconnecting it.

- 3 Drain the plate heat exchanger.

**! NOTE**

Avoid vacuum in the plate heat exchanger by opening vent valves.

- 4 If there are any protection sheets, remove them.

- 5 Disassemble pipes from the pressure plate and the connection plate(s) so that the pressure plate and the connection plate(s) are free to move along the carrying bar.

- 6 Inspect the sliding surfaces of the carrying bar. Wipe the sliding surfaces clean and put grease on them.

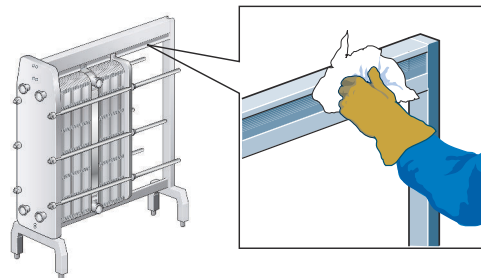

- 7 Mark the plate assembly on the outside with a diagonal line.

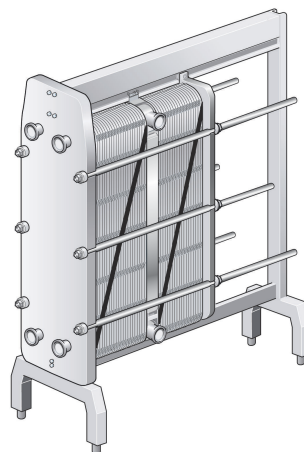



- 8 Check and note the **A** measure.

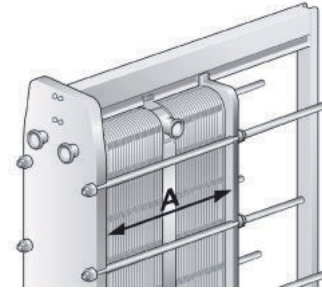

- 9 Loosen and remove the locking bolts. Identify them according to *Bolt configuration* on page 55.

**NOTE**

Brush the threads of the tightening bolts with a steel wire brush and then grease the threads before loosening the tightening bolts.

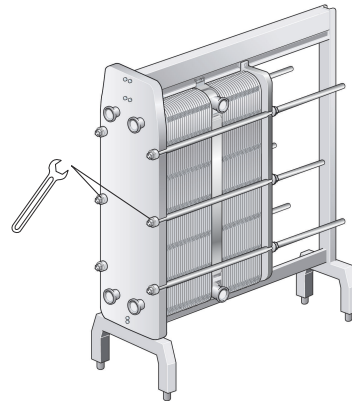

- 10 Use the tightening bolts to open the plate heat exchanger. During the opening procedure, keep the frame plate and pressure plate parallel. Skewing of the pressure plate during opening must not exceed 10 mm (2 turns per bolt) across the width and 25 mm (5 turns per bolt) vertically.

Loosen the four tightening bolts (1), (2), (3), (4) diagonally until the plate pack measure is  $1.05 \times A$  making sure that the frame plate and pressure plate are parallel while opening. Continue alternating between each bolt until all reaction forces of the plate pack have disappeared. Then remove the bolts.

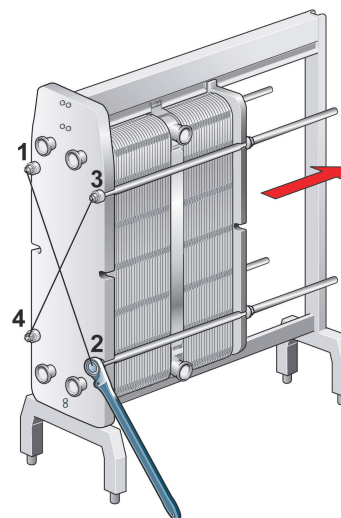

11

 **CAUTION**
**Risk of personal injury.**

Plates and protection sheets has sharp edges.

Wear personal protective equipment when handling the plates and the protection sheets. See Section *Personal protective equipment* in Chapter *Safety*.

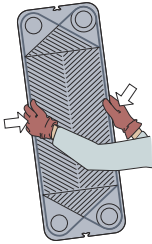

Open the plate pack by letting the pressure plate glide on the carrying bar.

If plates are to be numbered, do this before removing the plates.

Plates need not be removed if cleaning is done using only water, i.e. without a cleaning agent.

 **WARNING**
**Risk of personal injury.**

The plate pack may still contain a small residual amount of liquid after draining.

Depending on the type of product and type of installation, special arrangements like a drainage box, may be necessary to use to avoid injury to personnel and damage to equipment.

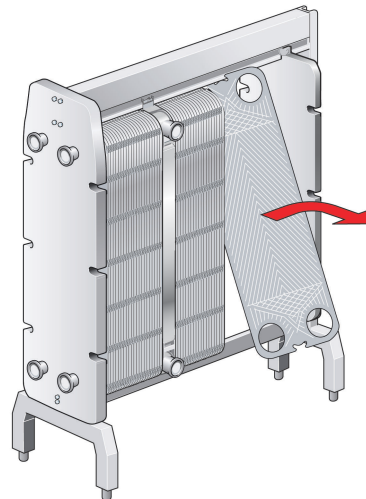

## 6.4 Manual cleaning of opened units

### CAUTION

Never use hydrochloric acid with stainless steel plates. Water of more than 330 ppm Cl may not be used in the preparation of cleaning solutions.

It is very important that aluminium carrying bars and support columns are protected against chemicals.

### NOTE

Be careful not to damage the gasket during manual cleaning.

### WARNING Risk of personal injury.

Use proper personal protective equipment when using the cleaning agents. See Section *Personal protective equipment* in Chapter *Safety*.

### WARNING Risk of personal injury.

Corrosive cleaning liquids. Can cause serious injuries to skin and eyes.

Use proper personal protective equipment when using the cleaning agents. See Section *Personal protective equipment* in Chapter *Safety*.

### 6.4.1 Deposits removable with water and brush

Plates do not need to be removed from the plate heat exchanger during cleaning.

### WARNING Risk of personal injury.

Consider risks such as loose particles and the kind of media that has been used in the plate heat exchanger.

Use proper personal protective equipment. See Section *Personal protective equipment* in Chapter *Safety*.

- 1 Start cleaning when the heating surface is still wet and the plates are hanging in the frame.
- 2 Remove deposits using a soft brush and running water.

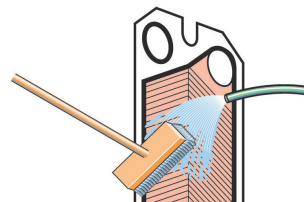

- 3 Rinse with water using a high pressure hose.

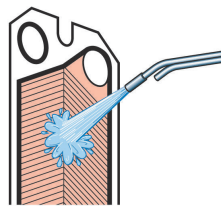

### 6.4.2 Deposits not removable with water and brush

Plates must be removed from the plate heat exchanger during cleaning. For a choice of cleaning agents, see Section [Cleaning liquids](#) on page 53.

- 1 Brush with cleaning agent.

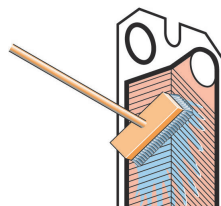

- 2 Rinse immediately with water.

**!** NOTE

Long exposure to the cleaning agents can damage the gasket glue.

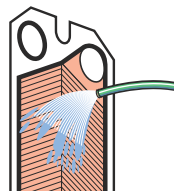

## 6.5 Closing

Follow the instructions below to ensure that the plate heat exchanger will be properly closed.

For bolt identification, see Section [Bolt configuration](#) on page 55.

- 1 Check that the hanger device is not damaged.
- 2 Brush the threads of the bolts clean, using a steel wire brush or the Alfa Laval thread cleaner. Lubricate the threads with a thin layer of grease, for example Gleitmo 800 or equivalent.

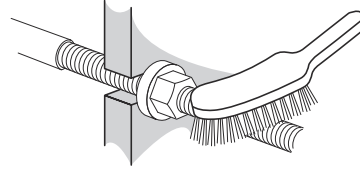

- 3 Attach the gaskets to the plates or check that all gaskets are properly attached. Check that all gaskets are correctly positioned in the grooves.

### ! NOTE

If the gasket is wrongly positioned, it will show by the fact that it rises out of the gasket groove or that it is positioned outside the groove.

- 4 If the plates have been removed, insert them in alternate directions and with the gaskets turned towards the frame plate or pressure plate as specified on the plate hanging list. Use the marked line that was made when the plate heat exchanger was opened, see Procedure [Opening - Procedure](#).

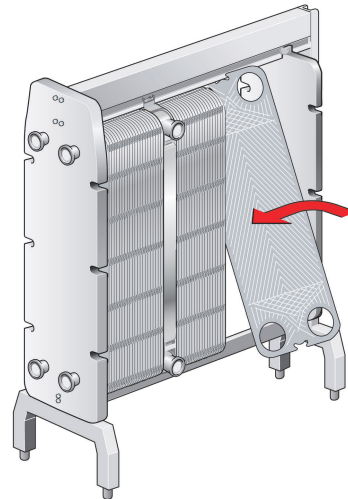

- 5 If the plate pack has been marked on the outside, check this according to Procedure [Opening - Procedure](#). If the plates are correctly assembled (A/B/A/B etc.), the edges form a "honeycomb" pattern, see picture.

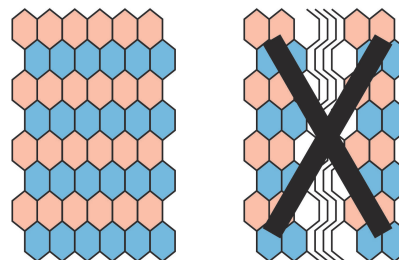

- 6 Press the plate pack together. Position the four tightening bolts according to the illustration. Tighten the four bolts (1), (2), (3), (4) until the plate pack measure is  $1.10 \times A$  making sure the frame plate and pressure plate are parallel when closing.

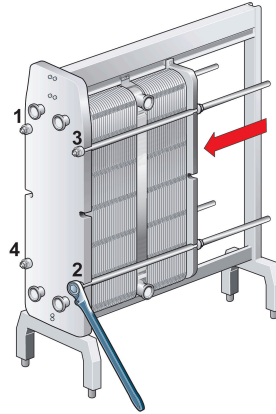

- 7 Tighten the four bolts (1), (2), (3), (4) evenly until the **A** measure has been reached.

When a pneumatic tightening device is used, see table below for maximum torque. Check the **A** measure during tightening.

Bolt size	Bolt with bearing box		Bolt with washer	
	Nm	kpm	Nm	kpm
M16			135	13.5
M24	295	29.5		
M30	585	58		
M39	1300	130		

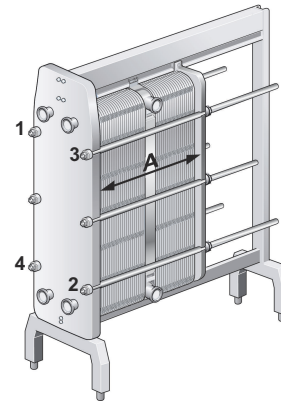

For manual tightening, the tightening torque has to be estimated.

If the **A** measure cannot be reached:

- Check the number of plates and the **A** measure.
- Check that all the nuts and bearing boxes are running freely. If not, clean and lubricate, or replace.

- 8 Assemble the remaining locking bolts and check the **A** measure on both sides, top, and bottom.

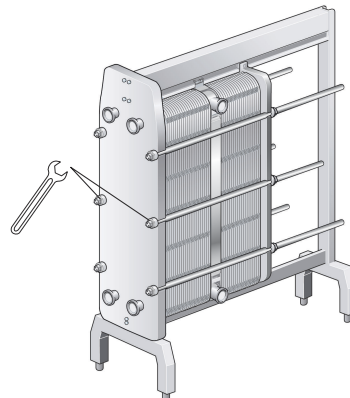

- 
- 9 Install protection sheets (if provided).
  - 10 Connect the pipes.
  - 11 If the plate heat exchanger does not seal when the **A** measure has been reached, it can be tightened further to the given **A** measure value minus 0.5%.
-

## 6.6 Pressure test after maintenance

Neither of these processes are allowed unless performed by a person authorized according to local laws and regulations and following applicable standards. If no such person is internally available, a third party authorized entrepreneur working per local legislation using proper equipment shall be engaged.

Before the start-up of production, whenever plates or gaskets have been removed, inserted or exchanged, it is strongly recommended to perform a hydrostatic leakage test to confirm the internal and external sealing function of the plate heat exchanger. In this test, one media side at a time must be tested with the other side open to the ambient pressure. In a multi-pass set up, all sections of the same side must be tested simultaneously. The recommended test time is 10 minutes for each media side.

 **CAUTION** Risk of damage to equipment.

The recommended pressure for the leakage test is a pressure equal to the operating pressure + 10% of the actual unit but never above the allowable pressure (PS) as stated on the name plate.

 **WARNING** Risk of personal injury.

Testing by putting gas (compressible media) under pressure can be very dangerous. Local laws and regulations regarding to the hazard involved in testing with a compressible medium must be respected. Hazardous examples are explosion risk due to uncontrolled medium expansion and/or suffocation risk due to oxygen depletion.

 **WARNING** Risk of damage to equipment.

Any rebuilding or modification of the plate heat exchanger is the responsibility of the end user. Regarding recertification and pressure test (PT) of the plate heat exchanger the local laws and regulations for in service inspection must be respected. Example of a rebuilding is that more number of plates are added to the plate pack.

If there is any uncertainty about the testing procedure of the plate heat exchanger, consult an Alfa Laval representative.



## 6.7 Regasketing

### ! NOTE

For Front 15, you must perform actions in addition to the instructions below to make the gaskets seal properly. Contact your Alfa Laval representative for advice.

The procedures below concern field gaskets, ring gaskets and end gaskets.

### ! NOTE

Before removing the old gaskets, check how they are attached.

### 6.7.1 Clip-on / ClipGrip

- 1 Open the plate heat exchanger, refer to [Opening](#) on page 55.

### ! NOTE

Before opening the plate heat exchanger, check the warranty conditions. If in any doubt, contact the Alfa Laval sales representative. See Section [Warranty conditions](#) in Chapter [Introduction](#).

- 2 Remove the old gasket with the plate still hanging in the frame.
- 3 Make sure that all sealing surfaces are dry, clean and free of foreign matter such as fat, grease or similar.
- 4 Check the gasket and remove rubber residual before attaching it.

### ! NOTE

Especially the end plate gasket!

- 5 Attach the gasket to the plate. Slip the gasket tabs under the edge of the plate.

**NOTE**

Make sure the two gasket prongs are in the correct position.

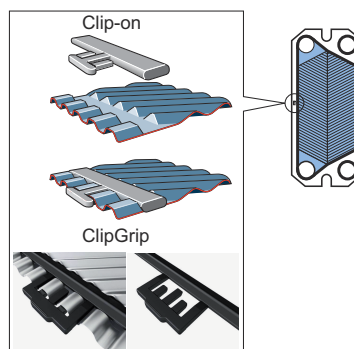

- 6 Repeat the procedure on all the plates that needs to be regasketed. Close the plate heat exchanger according to [Closing](#) on page 61.

# 7 Storage of the plate heat exchanger

## **WARNING** Risk of damage to equipment.

The crate is not designed to be stacked.  
Never put a load on top of the crate.

Alfa Laval delivers the plate heat exchanger ready to be put into service upon arrival, if nothing else has been agreed.

If storing for longer periods of time, such as one month or longer, certain precautions should be made to avoid unnecessary damage to the plate heat exchanger. See Sections [Outdoor storage](#) on page 67 and [Indoor storage](#) on page 67.

## **NOTE**

Alfa Laval and its representatives reserve the right to inspect the storage space and/or equipment whenever necessary until the expiration of the warranty period stipulated in the contract. Notification must be given 10 days prior to the date of inspection.

If there is any uncertainty about the storage of the plate heat exchanger, consult an Alfa Laval representative.

## 7.1 Storage in crate

If storage of the plate heat exchanger after delivery is known in advance, inform Alfa Laval when ordering the plate heat exchanger to ensure that it will be properly prepared for storage before packing.

### Indoor storage

- Store inside a room with the temperature between 15 and 20 °C (60 and 70 °F) and humidity up to 70%. For outdoor storage read [Outdoor storage](#) on page 67.
- To prevent damage to the gaskets, there should not be any ozone-producing equipment in the room such as electric motors or welding equipment.
- To prevent damage to the gaskets, do not store organic solvents or acids in the room and avoid direct sunlight, intensive heat radiation or ultraviolet radiation.
- The tightening bolts should be well covered with a thin layer of grease. See Section [Closing](#) on page 61.

### Outdoor storage

If you need to store your plate heat exchanger outdoors, follow all the precautions in [Indoor storage](#) on page 67 as well as the precautions listed below.

The stored plate heat exchanger shall be visually checked every third month. When closing the packing it shall be restored to original condition. The check includes:

- Greasing of the tightening bolts
- Metal port covers
- Protection of the plate pack and gaskets
- The packing

## 7.2 Taken out of service

If, for any reason, the plate heat exchanger is shut down and taken out of service for a long period of time, follow the precautions in [Indoor storage](#) on page 67. However, before storage the following actions must be done.

- Check the measurement of the plate pack (measure between frame plate and pressure plate, the **A** measure).
- Drain both media sides of the plate heat exchanger.
- Depending on media, the plate heat exchanger should be rinsed and then dried.
- The connection should be covered if the piping system is not connected. Use a plastic or plywood cover for the connection.
- Cover the plate pack with non-transparent plastic film.

### Start-up after long-term out of service

If the plate heat exchanger has been taken out of service for an extensive period of time, longer than one year, the risk of leakage when starting up increases. To avoid this problem it is recommended to let the gasket rubber rest to regain most of its elasticity.

1. If the plate heat exchanger is not in position, follow the instructions in [Installation](#) on page 23.
2. Note the measurement between frame plate and pressure plate (the **A** measure).
3. Remove the feet attached to the pressure plate.
4. Loosen the tightening bolts. Follow the instructions in [Opening](#) on page 55. Open the plate heat exchanger until the plate pack measure is  $1.25 \times \mathbf{A}$ .
5. Leave the plate heat exchanger for 24–48 hours, the longer the better, for gaskets to relax.
6. Re-tighten according to the instructions in [Closing](#) on page 61.
7. Alfa Laval recommends a hydraulic test should be carried out. The media, usually water, should be entered at intervals to avoid sudden shocks to the plate heat exchanger. It is recommended to test up to the Design Pressure. See the PHE drawing.