



Instruction Manual

Alfa Laval Toftejorg™ TZ-66



Covering:
Standard Machines
Machines delivered with ATEX Certification in accordance with Directive 94/9/EC valid until 2016-04-19/
Directive 2014/34/EU valid from 2016-04-20
TE91A300
First published: 1990

ESE01795-EN12 2019-05

Original manual

The information herein is correct at the time of issue but may be subject to change without prior notice

1. EC/EU Declaration of Conformity	4
2. Safety	5
2.1. Important information	5
2.2. Warning signs	5
3. Introduction	6
3.1. Introduction	6
3.2. Intended Use	6
3.3. Patents and Trademarks	6
3.4. ATEX Marking	7
3.5. Quality System	7
4. Installation	8
4.1. General Description	8
4.2. Functioning	8
4.3. General safety and installation instructions	9
4.4. Special Conditions for Safe Use in Accordance with ATEX Certification	11
5. Operation	12
5.1. Normal operation	12
6. Maintenance	13
6.1. Service and Repair of ATEX Certified Machines	13
6.2. Preventive Maintenance	14
6.3. Top Assembly	15
6.4. Bottom Assembly	17
6.5. Hub Subassembly	19
6.6. Stem Subassembly	21
6.7. Gear Subassembly	23
6.8. Replacement of Collar Bushes	25
6.9. Replacement of ball races	27
6.10. Replacement of Main Collars	29
7. Trouble Shooting Guide	30
8. Technical Data	31
9. Product Programme	35
9.1. Standard Configurations	35
9.2. Standard options	35
9.3. Available add-ons	36
10. Parts List and Drawing, Service Kits and Tools	37
10.1. Reference List of Parts TZ-66	37
10.2. Cross Sectional Drawing TZ-66	38
10.3. Spare Parts Kits and Service Kits	39
10.4. Tools	41
11. General Information	43
11.1. Service and Repair	43
11.2. How to Order Spare Parts	43
11.3. How to contact Alfa Laval Tank Equipment	43

1 EC/EU Declaration of Conformity

The Designated Company

Alfa Laval Kolding A/S

Company Name

Albuen 31, DK-6000 Kolding, Denmark

Address

+45 79 32 22 00

Phone No.

hereby declare that

Tank Cleaning Machine

Designation

Alfa Laval Toftejorg TZ-66

Type

From serial number 2016-0001 to 2030-99999

is in conformity with the following directive with amendments:

Machinery Directive 2006/42/EC

DS/EN ISO 12100:2011

The Pressure Directive 97/23/EC

According to its own volume and the rated pressure range, the product is regarded an Article 3, paragraph 3 Equipment

FDA 21CFR§177

Regulation (EC) 1935/2004

Equipment Explosive Atmospheres (ATEX) Directive 94/9/EC, valid until 2016-04-19

Equipment Explosive Atmospheres (ATEX) Directive 2014/34/EU, valid from 2016-04-20

(Applicable for machine certified as category 1 and 2 component, see machine engraving)

DS/EN 13463-1:2009, DS/EN 13463-5:2011, DS/EN ISO/IEC 80079-34:2011, Annex A, paragraph A.5.3 Rotating machines

EC Type Examination Certificate no. Baseefa10ATEX0188X

Marking:  II 1 GD c T175°C Tamb 0°C to +140°C

SGS Fimko Oy, Certification body number 0598, Särkiniementie 3, Helsinki, 00211, Finland

The person authorised to compile the technical file is the signer of this document

Global Product Quality Manager
Pumps, Valves, Fittings and Tank Equipment

Title

Lars Kruse Andersen

Name



Signature

Kolding

Place

2019-05-01

Date

(This Declaration of Conformity replaces Declaration of Conformity dated 2016-02-01)



*Unsafe practices and other important information are emphasized in this manual.
Warnings are emphasized by means of special signs.
Always read the manual before using the tank cleaning machine!*

2.1 Important information

WARNING

Indicates that special procedures must be followed to avoid serious personal injury.

CAUTION

Indicates that special procedures must be followed to avoid damage to the tank cleaning machine

NOTE

Indicates important information to simplify or clarify procedures.

2.2 Warning signs

General warning:



3 Introduction

3.1 Introduction

This manual has been prepared as a guide for installing, operating and maintaining your Alfa Laval Toftejorg tank cleaning machine. Should you require further assistance, our Technical Sales Support department and worldwide net of sales offices will be pleased to help you. Please quote the type, article and serial numbers with all of your enquiries; this helps us to help you. The type and serial number are placed on the gear house of the tank cleaning machine.

Important information: Before installing the machine and setting it into operation, carefully read the General Safety and Installation Instructions (page 9) and the special conditions for safe use in accordance with ATEX Certification Directive 94/9/EC valid until 2016-04-19/Directive 2014/34/EU valid from 2016-04-20 (page 11) and take all necessary precautions according to your application and local regulations.



NOTE

The illustrations and specifications contained in this manual were effective at the date of printing. However, as continuous improvements are our policy, we reserve the right to alter or modify any unit specification on any product without prior notice or any obligation.

The English version of the instruction manual is the original manual. We make reservations in regard to possible mistranslations in language versions of the instruction manual. In case of doubt, the English version of the instruction manual applies.

© Alfa Laval Corporate AB

This document and its contents is owned by Alfa Laval Corporate AB and protected by laws governing intellectual property and thereto related rights. It is the responsibility of the user of this document to comply with all applicable intellectual property laws. Without limiting any rights related to this document, no part of this document may be copied, reproduced or transmitted in any form or by any means (electronic, mechanical, photocopying, recording, or otherwise), or for any purpose, without the expressed permission of Alfa Laval Corporate AB. Alfa Laval Corporate AB will enforce its rights related to this document to the fullest extent of the law, including the seeking of criminal prosecution.

3.2 Intended Use

The end-user should verify:

- that the tank cleaning machine is in conformity with respect to tank, vessel or container size in which it is used.
- that the construction materials (both metallic and non-metallic) are compatibility with product, flushing media, cleaning media, temperatures and pressure under the intended use.

3.3 Patents and Trademarks

This Instruction Manual is published by Alfa Laval without any warranty. Improvements and changes to this Instruction Manual may at any time be made by Alfa Laval without prior notice. Such changes will, however, be incorporated in new editions of this Instruction Manual.

Alfa Laval Kolding A/S. All rights reserved.

The Alfa Laval logotype is a trademark or a registered trademark of Alfa Laval Corporate AB. "Toftejorg" is a trademark or registered trademark of Alfa Laval. Other products or company names mentioned herein may be the trademarks of their respective owners. Any rights not expressly granted herein are reserved.

3.4 ATEX Marking

**If ordered with ATEX certificate:
ATEX Marking**

The Alfa Laval Toftejorg TZ-66 is certified as category I components. The certification is carried out by the notified body SGS Fimko Oy, who has issued the certificate no. 10ATEX0188X. The marking on the ATEX certified Alfa Laval Toftejorg TZ-66 is as follows:

Rotary Jet Head
“TZ-xx”
s/n.: yyyy-xxxxx

Alfa Laval, DK-6000 Kolding, Albuen 31
 II 1GD c T175°C Tamb 0°C to +140°C
 0598 Baseefa 10ATEX0188X

“TZ-xx”: TZ machine type

Serial number explanation

Machines supplied with or without standard documentation:
yyyy-xxxxx: serial number
yyyy: year
xxxxx: 5 digit sequential number

Changes to the machine are not allowed without approval by the person responsible for the ATEX certification at Alfa Laval. If changes are made – or spare parts other than Alfa Laval original spare parts are used - the EC Type Examination certification (the ATEX Directive) is no longer valid.

Important ATEX information: Also see page 14 regarding special conditions for repair of ATEX certified machines.



3.5 Quality System

The Alfa Laval Toftejorg tank cleaning machines are produced according to Alfa Laval Kolding's ISO 9001 international Standard certified quality system.

4 Installation

4.1 General Description

The Alfa Laval Toftejorg TZ-66 is a media driven and media lubricated tank cleaning machine. As it is self lubricating, there is no lubricating substances such as oil, grease etc. in the machine which needs to be regularly changed.

4.2 Functioning

The flow of the cleaning fluid passes through a guide and a turbine, which accordingly is set into rotation. The turbine rotation is through a gearbox transformed into a combined horizontal rotation of the machine body and a vertical rotation of the nozzles.

The combined motion of the machine body and the nozzles ensures a fully indexed tank cleaning coverage. After $5 \frac{5}{8}$ revolutions of the Hub with nozzles ($5 \frac{3}{8}$ revolutions of the machine body) one coarse cleaning pattern is laid out on the tank surface. During the following rounds, this pattern is repeated 7 times, each of which is displaced $\frac{1}{8}$ of the mesh in the pattern. After a total of 45 revolutions of Hub with nozzles (43 revolutions of the machine body), a complete cleaning pattern has been laid out, and the first pattern is repeated.

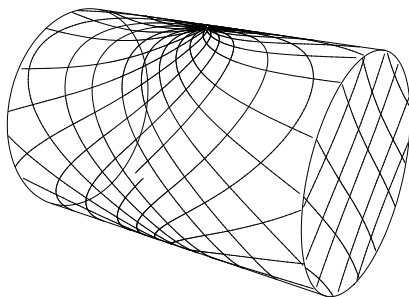

First cycle

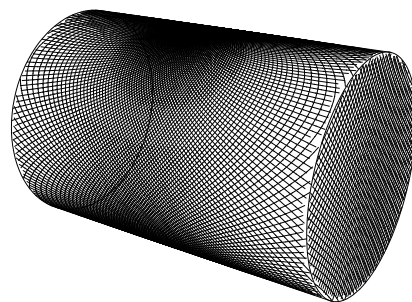

Full pattern

The speed of rotation of the turbine depends on the flow rate through the machine. The higher the flow rate the higher the speed of rotation will be. In order to control the RPM of the machine for a wide range of flow rates, the efficiency of the turbine can be changed (100% and 0% Turbine/Inlet guide).

Apart from the jet flow through the nozzles, fluid is leaking through the top of the machine, at the hub and through the bottom cover. The leakage between the moving parts at the top and at the hub are cleaning the gabs and thus preventing build-up of material that might cause the friction. The flow through the bottom cover is due to the fact that the machine is media lubricated and that accordingly a flow through the gearbox is needed.

4.3 General safety and installation instructions

The tank cleaning machine should be installed in a vertical position (upright or upside down). It is recommended to install a filter with mesh size of max. 3 mm in the supply line in order to avoid large particles to clog inside the machine. Before connecting the machine into the system, all supply lines and valves should be flushed to remove foreign matter.

Note: The machine shall be installed in accordance with national regulations for safety and other relevant regulations and standards. Precautions shall be made to prevent starting of the cleaning operation, while personnel are inside the tank or otherwise can be hit by jets from the nozzles. In EU-countries the complete system must fulfil the EU-machine Directive and depending of application, the EU-Pressure Equipment Directive, the EU-ATEX Directive and other relevant Directives and shall be CE-marked before it is set into operation.

ATEX

Warning:



If the machine is used in potential explosive atmospheres, tapes or joint sealing compounds which are electrical insulators must not be used on threads or joints, unless an electrical connection is otherwise established to ensure an effective earthing. In addition, connecting pipe work, must be electrically conductive and earthed to the tank structure. The resistance between the nozzles and the tank structure should not exceed 20,000 Ohm. This is essential to avoid the build-up of static electricity on the machine. For further information see IEC/TS 60079-32-1:2013, guidance and recommendations for the avoidance of hazards due to static electricity.

Electrical equipment such as magnetic valves and electric actuators must not be installed in Ex-zones without type approval and marking, corresponding to the EX-class in question.

To protect your tank coating it is recommended to mount bumpers on the tank cleaning machine.

The machine as delivered has been tested at the factory before shipping. For transportation reasons, the nozzles have been screwed off after the test. In order to secure the nozzles against falling off due to vibrations and other external strains it is important that the nozzles are tightened properly after mounting. If not, the nozzles may be blown off during tank cleaning and cause severe damage on tank, valves and pump. This is especially important if machines are fixed installed in tanks and vessels within the transportation sector in trucks, railcars and onboard ships.

Normally, it is sufficient to tighten the nozzles with the specified torque. However, depending on the application and local policies an extra securing may be preferred.

Subject to the intended use, environment and any inhouse user requirements or policies, a liquid threadlocker such as Loctite No. 243 or equivalent could be used. Other methods could be acceptable and subject to customer preference. For detailed instruction on pre-cleaning and application of the product carefully follow the instruction on the used locking system.

4 Installation

Method for tightening the nozzles

1. Clamp machine firmly in a vice. Protect machine with rubber pad under the machine and use rubber jaws on the vice. Mount jaws upside down to ensure firm grip on the machine. Set torque wrench at the specified tightening torque.
2. Hold one nozzle with flat spanner to counteract while tightening the opposite nozzle with the torque wrench.

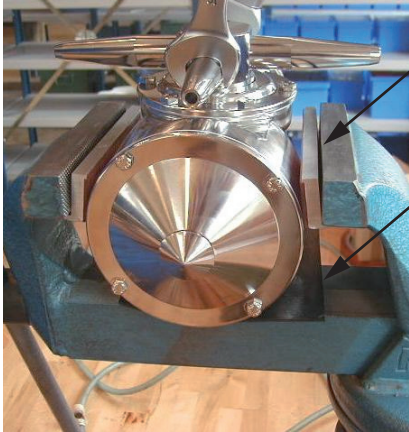

Rubber jaw mounted upside down

Protect with rubber pad



Recommended tightening torque: 50 Nm

3. Check that the machine is in operating condition by inserting Hex Screwdriver (tool No. TE134A) in screw in top of Turbine shaft and easily turn Turbine shaft clockwise. If any resistance is recognised, the machine should be disassembled to localise the cause.

4.4 Special Conditions for Safe Use in Accordance with ATEX Certification

Directive 94/9/EC valid until 2016-04-19

Directive 2014/34/EU valid from 2016-04-20

ATEX Warning: The unit may be operated, in a hazardous area, only when filled with the process fluid.



ATEX Warning: The maximum permitted process fluid temperature is 95°C, with an ambient temperature range of 0°C to 140°C.



ATEX Warning: The maximum permitted process fluid pressure is 12 bar.



ATEX Warning: The unit must **not** be operated in a vessel having an enclosed volume of greater than 100m³.



Tanks larger than 100 m³:

To use Tank Cleaning Machines in tanks larger than 100m³ is possible under certain conditions.

It is necessary to know the current factors such as tank size, cleaning solvent and product.

Additives can be used in the cleaning solvent, or, for example, the tank can be filled with nitrogen. The basic rules are described in the guide "IEC/TS 60079-32-1:2013".

Following a guidance document such as "IEC/TS 60079-32-1:2013" to establish safe use of machinery and process is the users own responsibility and is not covered by the ATEX certification for this product.

ATEX Warning: The unit must be effectively earthed at all times when in use.



ATEX Warning: The user must address the electrostatic hazards generated from the process of the equipment in accordance with guidance document IEC/TS 60079-32-1.



In addition to the above mentioned precautions relating to the ATEX guidelines Directive 94/9/EC valid until 2016-04-19/Directive 2014/34/EU valid from 2016-04-20, the Safety Precautions on page 9 must be observed.

5 Operation

5.1 Normal operation

Cargo and Cleaning Media

Use only cleaning media compatible with stainless steel AISI 316/316L, PTFE, Tefzel, PVDF, Carbon and PEEK. Please note that PEEK is not resistant to concentrated sulfuric acid. Normal detergents, moderate solutions of acids and alkalis will be acceptable. Aggressive chemicals, excessive concentrations of chemicals at elevated temperatures, as well as certain dissolvents and hypochlorites should be avoided. If you are in doubt, contact your local Alfa Laval sales office.

After Use Cleaning

After use flush the machine with fresh water. Cleaning solutions should never be allowed to dry or set-up in the system due to possible "salting out" or "scaling" of the cleaning ingredient. If cleaning media contains volatile chloride solvents, it is recommended **not to flush with water** after use, in case this can create hydrochloric acid.

Pressure

Avoid hydraulic shocks. Put on pressure gradually. Do not exceed 12 bar inlet pressure. Recommended inlet pressure appears from Technical Data (page 31). High pressure in combination with high flow rate will increase consumption of wear parts.

ATEX Warning: Steam Cleaning Pressure:



If steam cleaning is done through the machine, the steam pressure must not cause the machine to rotate.

ATEX Warning: Draining:



If the machine is drained using compressed air, then the compressed air pressure must not cause the machine to rotate.

Temperature:

In accordance with the ATEX specifications regarding special conditions for safe use, see page 11.

ATEX Warning: Steam Cleaning:



Tanks with capacities greater than 100 m³ that could contain a flammable atmosphere should not be steam cleaned, as steam issuing from a nozzle could contain charged droplets.

Tanks smaller than this may be steam cleaned providing that: the steam nozzles and other metal parts of the system are reliably earthed and grounded to the tank structure.

ATEX Warning: Atmosphere/surface temperature:



In potentially explosive atmospheres, the temperature must not exceed the maximum surface temperature according to the temperature class for the combustible gas or liquid.

6.1 Service and Repair of ATEX Certified Machines

All service and repair of ATEX certified machines can be performed by Alfa Laval Tank Equipment, Kolding, Denmark or by an Alfa Laval service center approved by Alfa Laval Tank Equipment.

**ATEX
Warning:**



In order to ensure compliance with the ATEX regulations and keep the machine ATEX certification valid the service or repair must be performed by an authorized person with knowledge of the ATEX requirements and regulations.

All spare parts must be original Alfa Laval spare parts and the repair or service must be done according to the instructions in the related manual.

If a customer wishes to carry out service or repair himself, it is the responsibility of the repair shop to ensure that the ATEX requirements are met in any way possible. After performing service or repair, the repair shop thus carries the full responsibility for traceability of all relevant documents in order to ensuring the retention of the ATEX certification of the machine.

6 Maintenance

6.2 Preventive Maintenance

In order to keep your tank cleaning machine servicing you as an efficient tool in your tank cleaning operations, it is essential to maintain its high performance by following a simple preventive maintenance programme, which will always keep your tank cleaning machine in good condition.

Good maintenance is careful and regular attention!

The following recommended preventive maintenance is based on tank cleaning machines working in average conditions. However, you will appreciate that a tank cleaning machine, which has a rough and dirty job to do, will need more frequent attention than one working in ideal conditions. We trust that you will adjust your maintenance programme to suit.

Always use only proper tools. Use standard tool kit. Never force, hammer or pry components together or apart. Always perform all assembly/disassembly steps in the order described in this manual.

Never assemble components without previous cleaning. This is especially important at all mating surfaces. Work in a clear well lighted work area.

Note: Recommended tightening torque for all screws: 4-5 Nm.

Every 300 working hours

1. Disassemble machine as described on the following pages.
2. Clean material build-up and deposits from internal parts with chemical cleaner and fine abrasive cloth.
3. Check Slide bearings (pos. 30 on the cross sectional drawing, page 38) for wear. If hole is worn oval to max. diameter more than 12.4 mm, Slide bearing should be replaced. If end face of Slide bearing is worn more than x mm into Slide bearing, it should be replaced.

Under Turbine shaft:	x = 1.5 mm
At Horizontal shaft:	x = 0.5 mm

4. Check Collar bushes (pos. 12) in Gear frame. If holes are worn oval to max. diameter more than 15.4 mm, Collar bush should be replaced. How to replace Collar bushes, see page 25.

Note: Timely replacement of Slide bearings and Collar bushes will prevent costly damage to the gear box.

5. Check Worm wheels (pos. 13 and pos. 14). If extremely worn, they should be replaced.
6. Check Main bush (pos. 6). If worn oval to max. diameter more than 15.4 mm, it should be replaced.
7. Assemble machines as described in the following pages.
8. Check that the machine is in operating condition by inserting hex Screwdriver (tool No. TE134A) in screw in top of Turbine shaft and easily turn Turbine shaft clockwise. If any resistance is recognized, the machine should be disassembled to localize the cause.

Apart from the parts specifically mentioned above, all the remaining wear parts should regularly be inspected for wear. Which parts that are wear parts appear from Reference Lists of Parts, page 37.

6.3 Top Assembly

Disassembly

1. Remove Screws (pos. 10). Loosen with Key (tool No. TE135) and unscrew with Screwdriver (tool No. TE135A).
2. Lift off Nipple (pos. 1).
3. Remove Guide /Guide ring (pos. 2). The Guide has a groove in the outer diameter. The Guide is easily lifted out of the Stem by means of two ordinary Screwdrivers inserted into the groove.
4. Remove Screw (pos. 17), Spring washer (pos. 16) and Washer (pos. 18). To secure Impeller against rotation, insert carefully Screwdriver (tool No. TE135A), through Impeller (pos. 4) into a hole in the Stem.
5. Pull off Impeller (pos. 4).

Reassembly

1. Reinstall Impeller (pos. 4). Make sure that Impeller is correctly rotated to be pushed onto Turbine shaft. Do not try to hammer Impeller in position, as this will damage Slide bearing under Turbine shaft.
2. Mount Washer (pos. 18), Spring washer (pos. 16) and Screw (pos. 17) and tighten. To secure Impeller against rotation insert carefully Screwdriver (tool No. TE135A) through Impeller (pos. 4) into a hole in the Stem.
3. Reinstall Guide/Guide ring (pos. 2).
4. Mount Nipple (pos. 1). Make sure that it is in correct position over Guide/Guide ring (pos. 2) Rotate Nipple to align holes in Nipple and Stem.
5. Mount Screws (pos. 10) with Screwdriver (tool No. TE135A). Tighten with Key (tool No. TE135).

6 Maintenance

Top Assembly

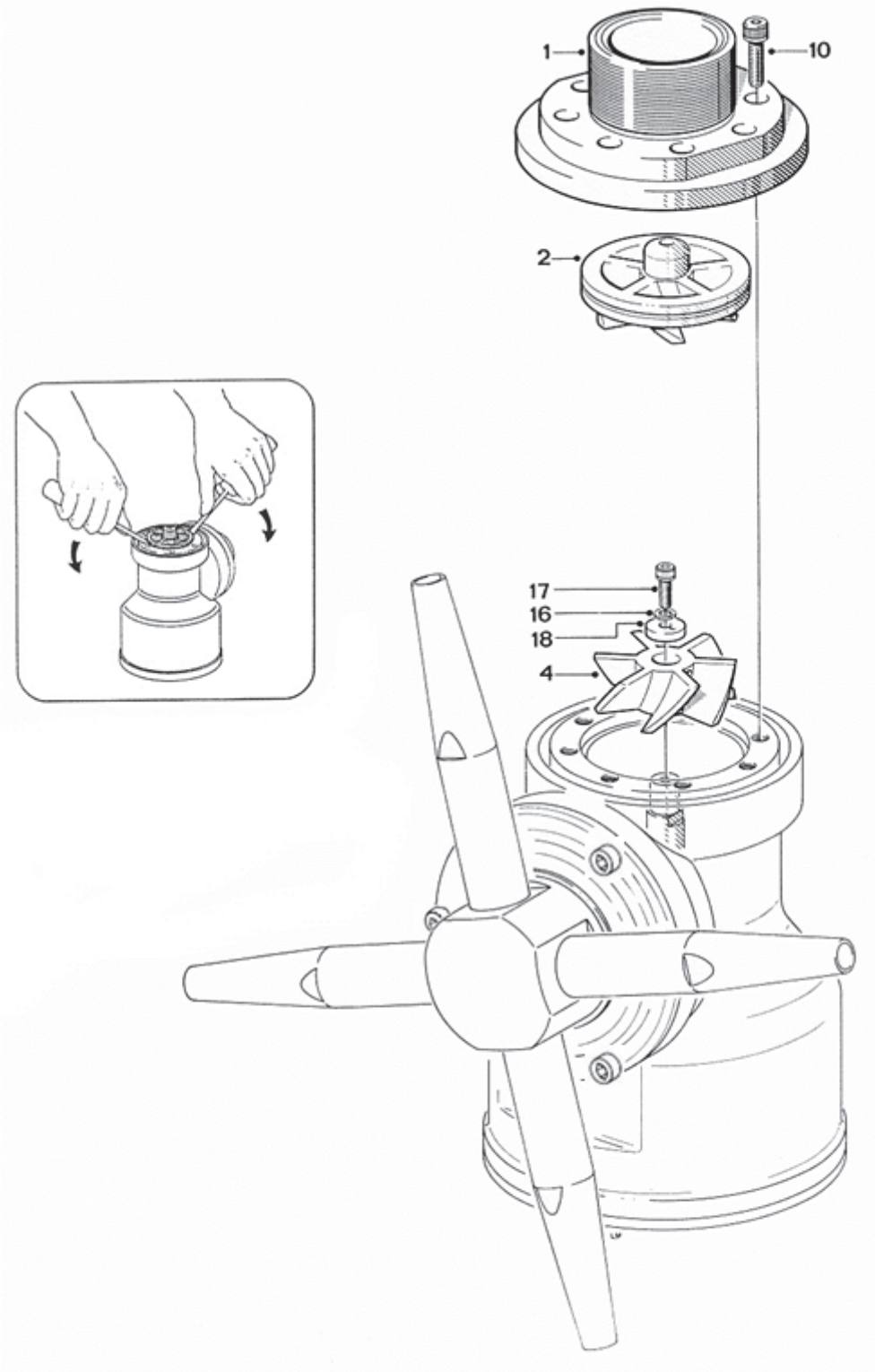

6.4 Bottom Assembly

Disassembly

1. Turn machine upside down.
2. Remove Screws (pos. 17) and Spring washer (pos. 16) from Bottom cover (pos. 33).
3. Remove Bottom cover (pos. 33).
4. Remove Screw (pos. 17) and Spring washers (pos. 16) along the circumference of Gear frame (pos. 31). Draw out Gear Subassembly (holes in Gear frame are excellent for holding Gear subassembly).

Reassembly

1. Reinsert Gear subassembly in bottom of machine body. Mount Spring washers (pos. 16) and Screws (pos. 17) along circumference of Gear frame (pos. 31). Tighten screws crosswise.

Note: Turbine shaft is inserted carefully through Gear wheel and Stem. Note also that to secure meshing between Gear wheel (pos. 8) and Pinion (pos. 11) it might be necessary to rotate slightly either the whole Gear subassembly or the Gear wheel.

2. Replace Bottom cover (pos. 33).
3. Mount Spring washer (pos. 16) and Screws (pos. 17) and tighten crosswise.

6 Maintenance

Bottom Assembly

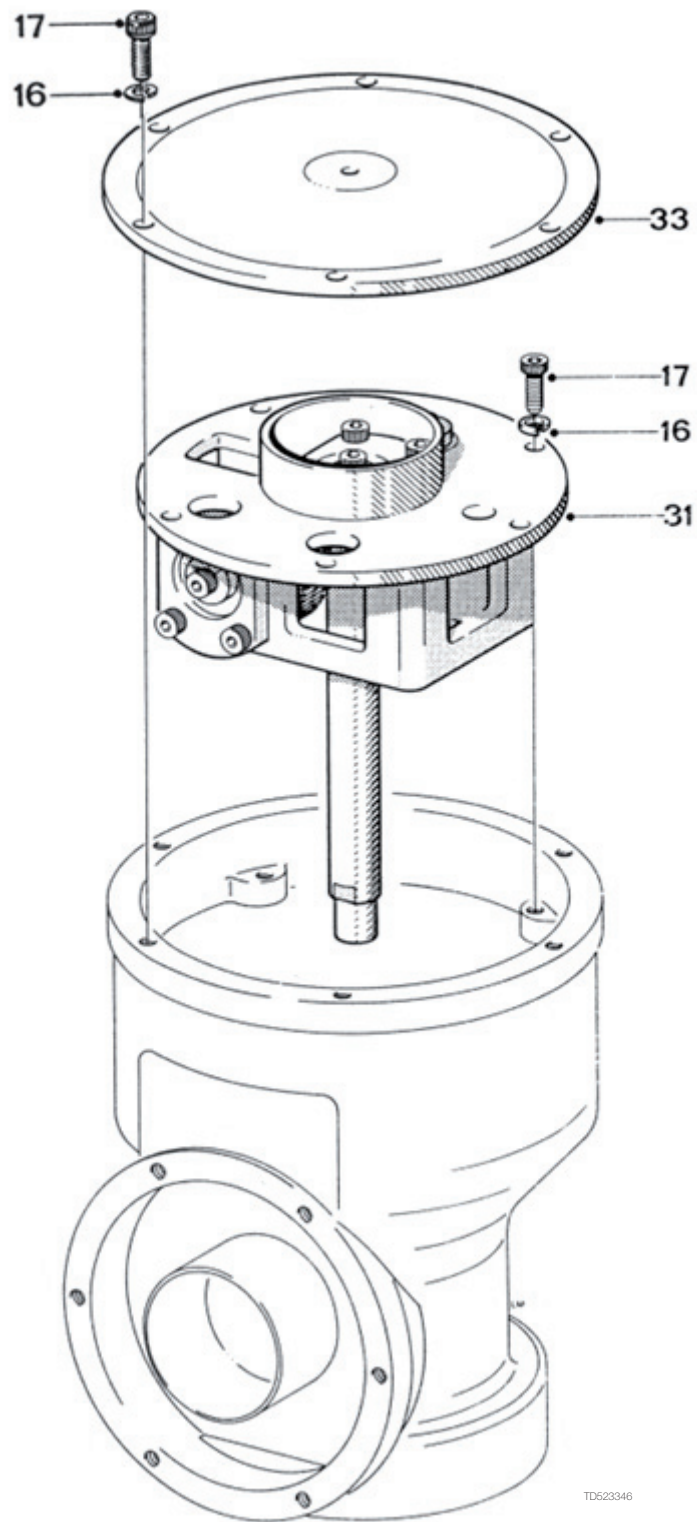

6.5 Hub Subassembly

Disassembly

1. Remove Nozzles (pos. 22). Nozzles are untightened with a wrench on the faces of the Nozzles.
2. Remove Screws (pos. 17) and Spring washer (pos. 16) from Hub cover (pos. 21).
3. Draw out Hub (pos. 23) together with Hub cover (pos. 21), Ball race (pos. 21.1), Ball retainer with balls (pos. 27) and Bevel gear (pos. 20). If Hub cover (pos. 21) clings into Body, knock carefully with plastic hammer on outer diameter to loosen.

If Ball races (pos. 20.1) and in Bevel gear (pos. 21.1) are extremely worn, they should be replaced as well as the Ball retainer with balls (pos. 27). How to replace Ball races see page 27.

If blue liners on Stem are extremely worn, they can be replaced. This part requires that a precise procedure is followed to accomplish installation. It is highly recommended that an authorized Alfa Laval Tank Equipment Service Center perform the replacement when necessary.

Reassembly

1. Slide on Hub (pos. 23).
2. Mount Bevel gear with race (pos. 20), Ball retainer with balls (pos. 27) and Hub cover (pos. 21) and Hub cover (pos. 21) and set with Spring washer (pos. 16) and Screw (pos. 17).
3. Screw on Nozzles (pos. 22) and tighten with wrench. If desired, secure with liquid threadlocker Loctite No. 243 or equivalent, see page 9.

6 Maintenance

Hub Assembly

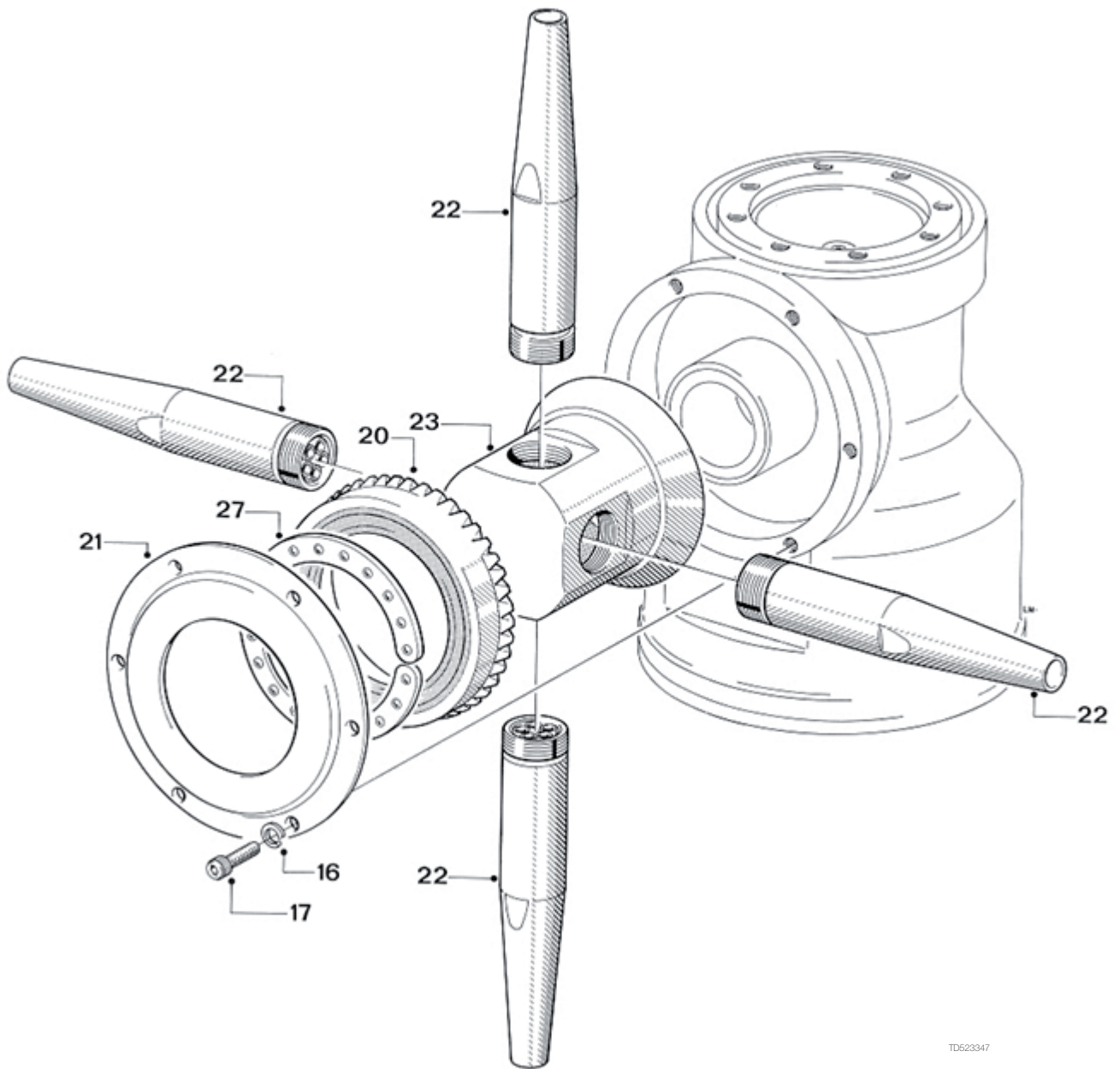

TD523347

6.6 Stem Subassembly

Disassembly

1. Place machine in upright position.
2. Unscrew Gland (pos. 5). Note: Left-hand thread. Push out Main bush (pos. 6).
3. Turn machine upside down.
4. Remove Screws (pos. 10) in Gear wheel (pos. 8). To prevent rotation of Stem (pos. 3) mount two screws in two holes opposite one another in BIG end of Stem. Place Stem in a vice held by the heads of the two screws..
5. Draw out Gear wheel with ball race (pos. 8) and Ball retainer with balls (pos. 27).
6. Push out Stem (pos. 3).

If Ball races in Body (pos. 28.3) and on Gearwheel (pos. 8.1) are extremely worn they should be replaced together with Ball retainer with balls (pos. 27). How to replace Ball races see page 27.

If blue liners on Stem are extremely worn, they can be replaced. This part requires that a precise procedure is followed to accomplish installation. It is highly recommended that an authorized Alfa Laval Tank Equipment Service Center perform the replacement when necessary.

Reassembly

1. Push Stem (pos. 3) into Body. Turn machine upside-down.
2. Place Ball retainer with balls (pos. 27) and Gear wheel (pos. 8) into Body on Ball race. Rotate Gear wheel to check free rotation.
3. Mount Gear wheel (pos. 8) with Screws (pos. 10) and tighten crosswise. To prevent rotation of Stem (pos. 3) mount two 1/4" screws in two holes opposite one another in BIG end of Stem. Place Stem in a vice held by the heads of the two screws.
4. Turn machine to upright position. Remount Main bush (pos. 6) in Gland (pos. 5) and screw into Stem (pos. 3). Note: Left-hand thread.

6 Maintenance

Stem Subassembly

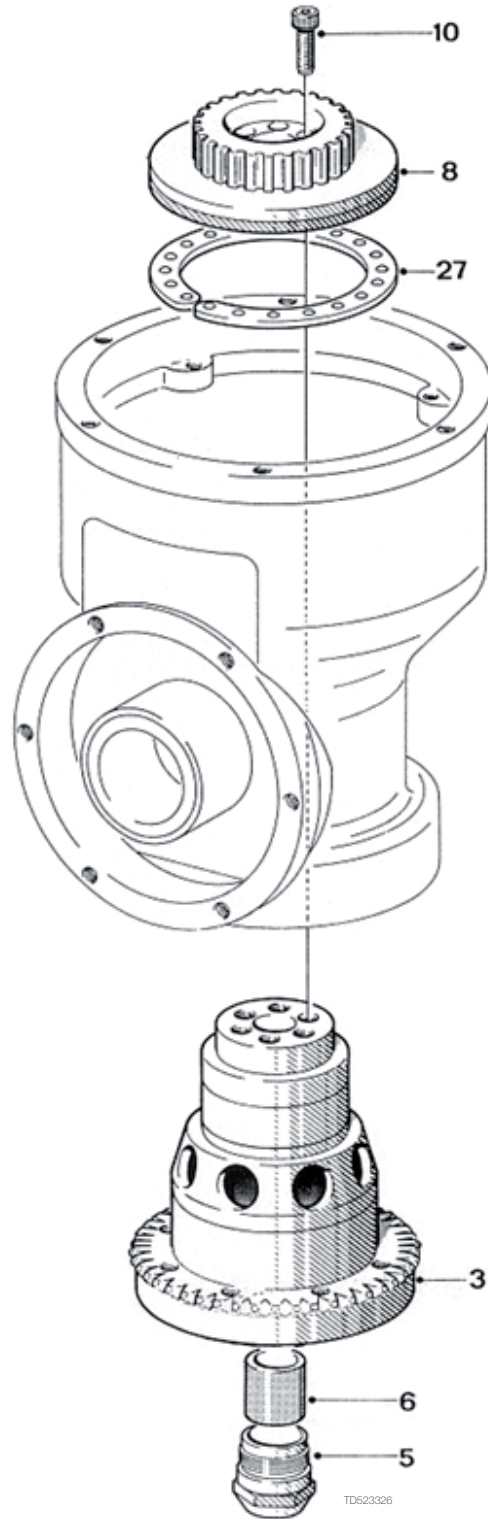

6.7 Gear Subassembly

Disassembly

1. Hold Turbine shaft (pos. 7) against 1st stage Worm wheel (pos. 14) with one hand and loosen Screws (pos. 17) in Pinion (pos. 11) and Horizontal shaft (pos. 29) with the other hand.
2. Draw out Turbine shaft (pos. 7) after Screw (pos. 17), Spring Washer (pos. 16) and Washer (pos. 18) has been removed. Use faces on Turbine shaft to hold against rotation.
3. Draw out Horizontal shaft (pos. 29) and 1st stage Worm wheel (pos. 14) after removal of Screw (pos. 17), Spring washers (pos. 16) and Washer (pos. 18).
4. Draw out Pinion (pos. 11) and 2nd stage Worm wheel (pos. 13), also freeing Journal (pos. 15) after removal of Screw (pos. 17), Spring washer (pos. 16) and Washer (pos. 18).
5. Remove Bearing covers (pos. 32) and Slide bearings (pos. 30) after removal of Screw (pos. 17).

How to replace Collar bushes (pos. 12), see page 25.

Warning:



Do not damage driver faces on Turbine shaft. Use only proper tools providing a firm grip such as a wrench or a vice.

Reassembly

1. Push Slide bearing (pos. 30) into Gear frame (pos. 31) and fix Bearing covers (pos. 32) with Screws (pos. 17). Tighten crosswise.
2. Insert 2nd stage Worm wheel (pos. 13), Pinion (pos. 11) and Journal (pos. 15). Mount Washer (pos. 18), Spring washer (pos. 16) and fix with Screw (pos. 17). Check rotation.

Note: It is important that the Screw holding the Pinion is fastened to a torque moment of 5 Nm, to secure it from loosening.

6 Maintenance

Gear Subassembly

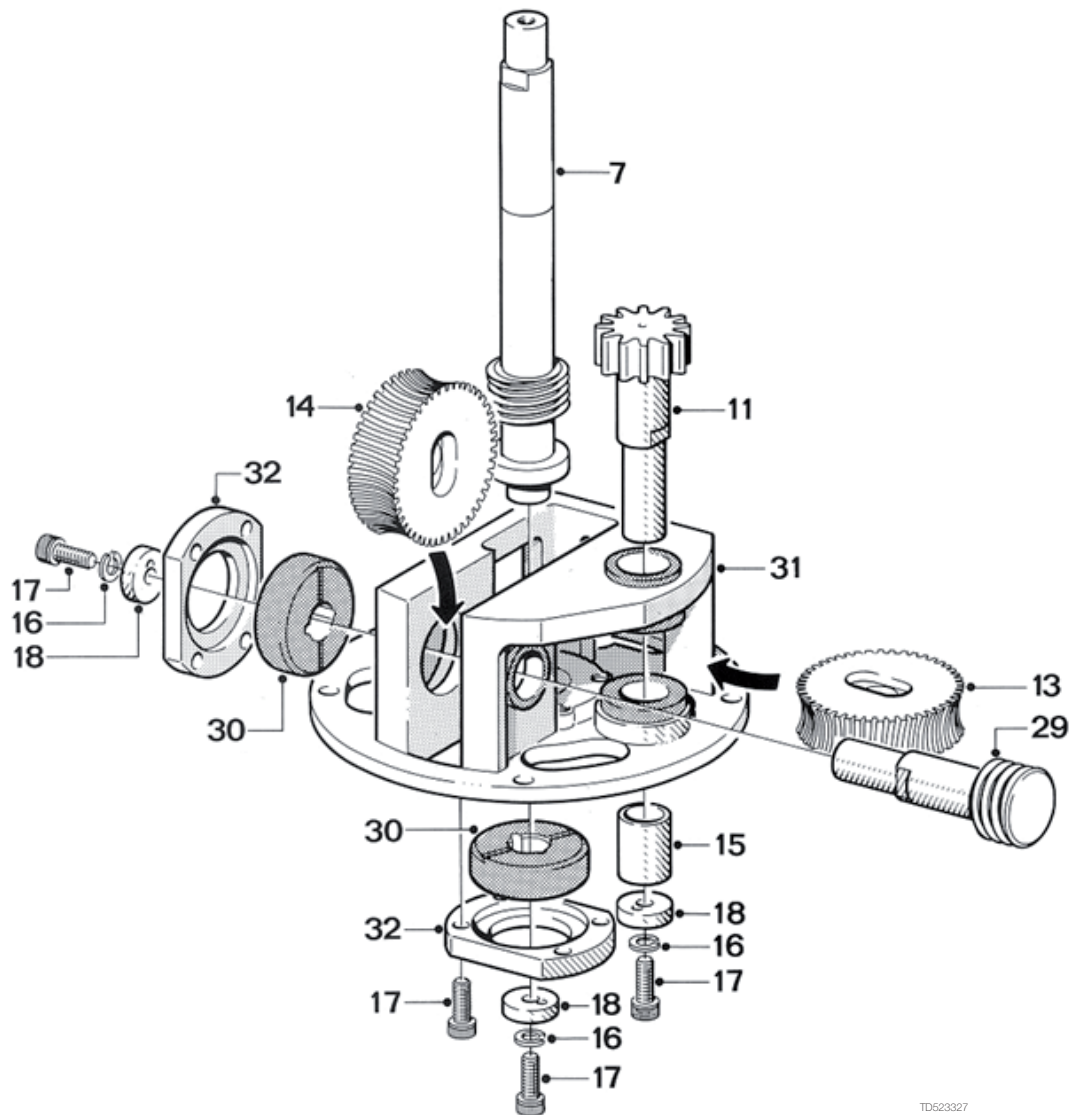

TD623327

3. Insert 1st stage Worm wheel (pos. 14) and Horizontal shaft (pos. 29). Mount Washer (pos. 18), Spring washer (pos. 16) and fix with Screw (pos. 17). Check rotation.
 4. Insert Turbine shaft (pos. 7). Mount Washer (pos. 18), Spring washer (pos. 16) and fix with Screw (pos. 17). Use faces on Turbine shaft to hold against rotation when tightening screw.
 5. Hold Turbine shaft (pos. 7) against 1st stage Worm wheel and tighten Screws (pos. 17) in Horizontal shaft (pos. 29) and Pinion (pos. 11). Check rotation on Turbine shaft.
-

6.8 Replacement of Collar Bushes

Replacement of Collar Bushes

1. Place Gear frame (pos. 31) upside down with a firm support under the flange. Use for instance jaws of a vice. Do not clamp on machined surfaces. With Pusher (tool No. TE81B031, see page 41) knock out Collar bush.
2. Turn Gear frame to upright position and hold over support such as flat steel bar clamped in a vice. Knock out Collar bush with Pusher.
3. Turn Gear frame 90° and hold over support. Knock out collar bush with Pusher.
4. Remove all remains of old Araldite etc. Holes must be perfectly clean before mounting new Collar bushes. Rinse with chemical cleaner.
5. Coat new Collar bushes with CIBA-GEIGY two component Standard blue Araldite and push into Gear frame.
6. To hold Collar bushes in correct position, insert fixtures (tool No. TE81B032, see page 41) and let harden according to instructions.

Warning:



To avoid risk of deforming Gear frame, it is utmost important that it is supported while the Collar bushes are being knocked out.

6 Maintenance

Removal of old Collar bushes

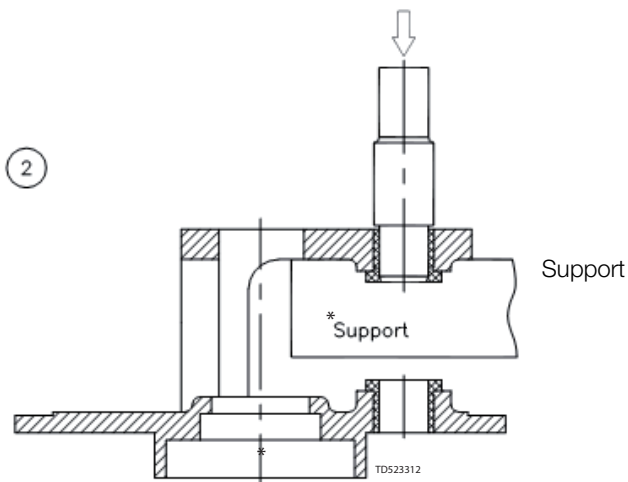
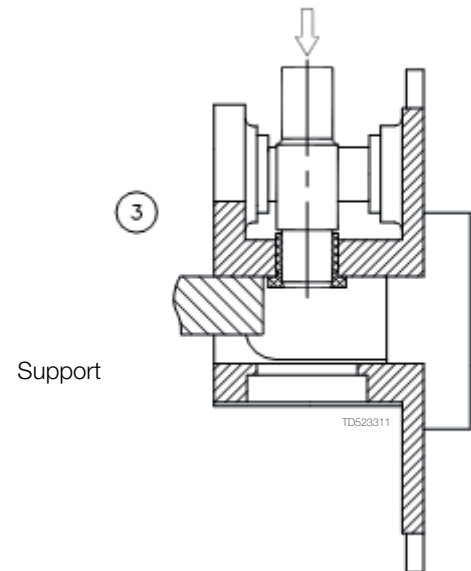
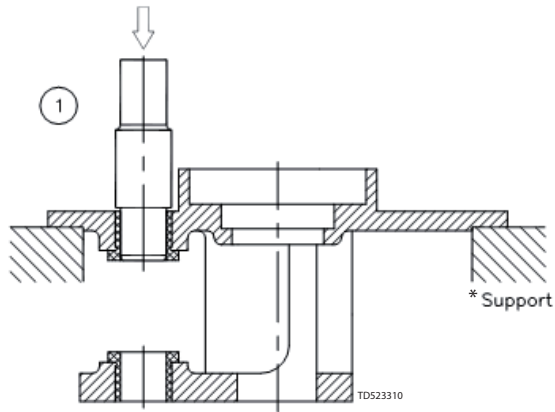

Mounting of new Collar bushes

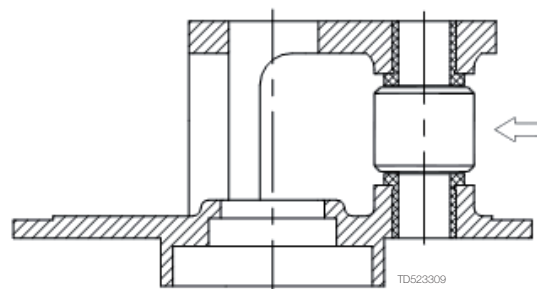
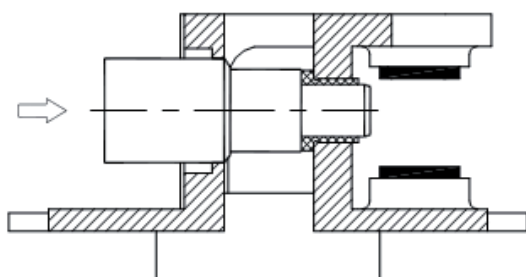

6.9 Replacement of ball races

In body

1.
 - A. With big end downwards knock several times Body with bearings (pos. 28) hard against firm wooden support until Ball race (pos. 28.3) drops out.
 - B. If it is not possible to knock out Ball race in this way, it is necessary first to screw out Main collar lower (pos. 28.2) – see page 29. Carefully push off old Ball race without damaging Main collar lower. Use mandrel and firm support. Before mounting of new Ball race, Main collar lower (pos. 28.2) must be remounted into Body – see page 29.
2. Clean surfaces and place Ball race (pos. 28.3) on Main collar lower (pos. 28.2). Press by hand as long as possible. By means of a tube mandrel or if desired wooden block, carefully hammer Ball races home.

Ball races must not project over end face of Main collar lower. To avoid tilting mandrel must push along the whole circumference of Ball race. Do not damage surface of Ball race.

On Gear wheel

1. Place Gear wheel with ball race (pos. 8) on support. Support only under Ball race (pos. 8.1). With mandrel press off old Ball race.
2. Clean surfaces and press on new Ball race. Ball race must be pressed fully home on Gear. Press parallel. Use press or vice. Do not damage surface of Ball race.

In Hub cover

1. Place Hub cover with ball race (pos. 21) on support. Carefully knock out old Ball race by means of small mandrel or if desired screwdriver. Knock several times around the circumference to avoid tilting.
2. Clean surfaces and press in new Ball race. Ball race must be pressed fully home. Press parallel. Do not damage surface of Ball race.

6 Maintenance

Replacement of Ball races

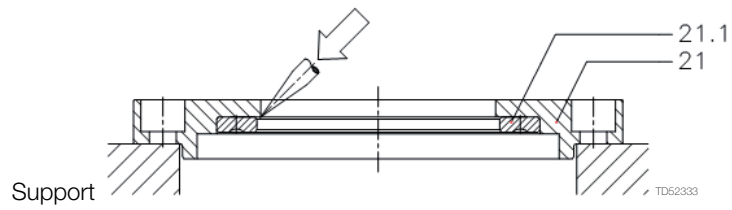
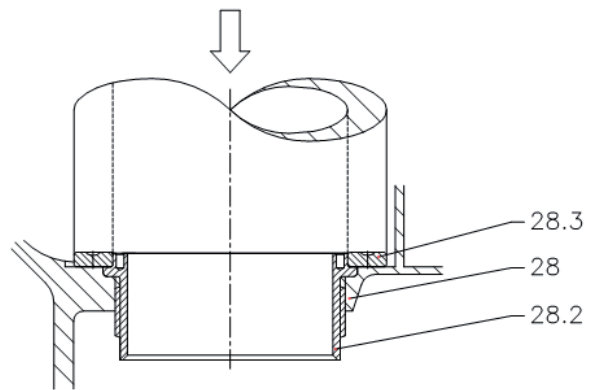
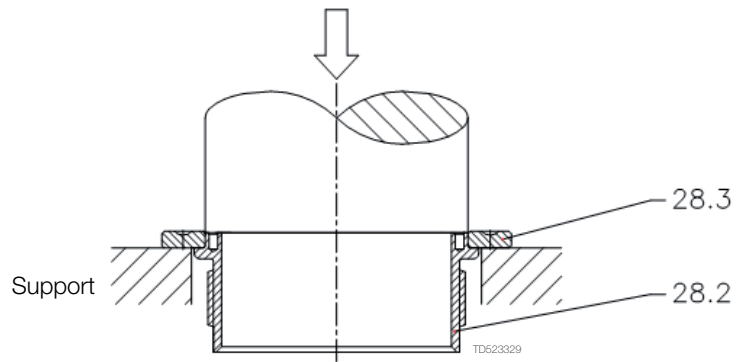

6.10 Replacement of Main Collars

Although normally exposed to very limited wear, it is possible to replace Main collars (pos. 28.1 and 28.2) in Body. The procedure to do this is described below.

Warning:



Replacement of Main collars involves risk of damaging the special threads and accordingly the body. It is recommended to let an authorized Alfa Laval sales office do the replacement.

Main collar upper

1. Place Body (pos. 28) in a vice upright position. Do not clamp on machined faces. Insert tool into Main collar upper (pos. 28.1). To loosen Loctite, knock hard on tool with hammer. Unscrew Main collar.
2. Carefully clean thread and recess in Body. Do not damage special thread in Body. Recess must be absolutely clean and free from remains of old Loctite. If desired, use solution of ethylene glycol.
3. Make sure that new Main collar is clean and free from impurities. Apply Loctite No. 243 on thread.
4. Screw in new Main collar. Attention should be given to make sure that thread is in correct engagement before screwing in Main collar.
5. Tighten Main collar fully home. Several times knock hard on tool and tighten up.
6. Check that Main collar is fully home: install Stem, Ball retainer with balls and Gear wheel (see page 21). Check that there is sufficient axial clearance to allow for free rotation of Stem.

Main collar lower

1. Place Body in a vice in upside down position and repeat procedure described above.

Warning: Thread on Main collar lower is left-handed.



Replacement of Main Collars

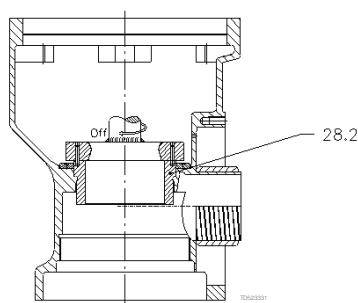
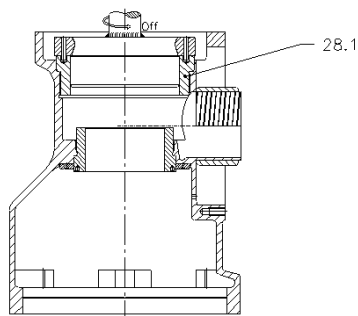

7 Trouble Shooting Guide

Slow rotation or failure of machine to rotate

Possible Causes	Fault finding
No or insufficient liquid flow	a). Check if supply valve is fully open b). Check if inlet pressure to machine is correct c). Check supply line and filter for restriction/clogging d). Remove Nozzles and check for clogging. If blocked, carefully clean Nozzle without damaging stream straighteners and Nozzle tip. e). Remove Flange/Nipple, Guide and Impeller (see page 15) and check for clogging in Impeller area. If large particles repeatedly get jammed in the machine, install filter or reduce mesh size of installed filter in supply line.
Foreign material or material build-up	Insert hex Screwdriver in Screw in top of Turbine shaft and easily turn Turbine shaft clockwise. If any resistance is recognised, disassemble machine in order to localise the cause.
a). Impeller jammed	Remove Guide and Impeller (see page 15) and remove foreign material.
b). Turbine shaft sluggish in Main bush	Remove gear Assembly (see page 23) and Gland (pos. 5) and clean Main bush.
c). Bevel gears jammed	Remove Flange/Nipple and Hub Assembly (see page 19). Clean teeth on Stem and Bevel gear.
d). Stem jammed/sluggish	Remove Gear Assembly (see page 23). Check free rotation of Stem. Remove Stem (see page 21). Remove foreign material/material build-up on Stem and inside Main collars. Clean Ball races and Ball retainer with balls. Also clean main bush.
e). Gearbox jammed/sluggish	Remove foreign material from Gearbox. Check rotation of shafts. If restriction is recognized, disassemble gearbox (see page 23) and remove material build up, especially on 2. Stage Worm wheel and mating Collar bushes.
f). Hub jammed/sluggish	Disassemble Hub Assembly (see page 19). Remove foreign material inside Hub. Clean Ball races and Ball retainer with balls. Also clean nose of Body.
Wear	
a) Slide bearings	See page 14.
b) Main bush	See page 14.
c) Worm wheels	See page 14.
d) Collar bushes	See page 14.
e) Turbine shaft	Check clearance in Main bush and in Slide bearing. Transverse movement should not exceed 0.5 mm. Also inspect Worm wheel for wear.
f) Horizontal shaft	Check clearance in Collar bushes. Transverse movement should not exceed 0.5 mm. Also inspect worm for wear.
Mechanical defects	
a). Worm wheels. Teeth broken	Replace Worm wheel.
b). Worm wheel can rotate on Horizontal shaft/Pinion due to damaged driver faces.	Replace Worm wheel.
c). Damaged teeth on gear	Inspect teeth on Stem and Hub for deformation. Mount Hub and Stem in Body (see page 19 and 21). Hold Body in upside down position and rotate Hub to check that Bevel gears can work together. If damaged: Replace Stem and/or Bevel gear.

Weight of machine:	13 kg (28.6 lb)
Working pressure:	2-12 bar (30-175 psi)
Recommended inlet pressure:	3-8 bar (45-120 psi)
Working temperature max.:	95°C (200°F)
Ambient temperature:	0 -140°C (95°C - 140°C when not operated)
Materials:	Stainless steel AISI 316/316L, PTFE, Tefzel, PVDF, Carbon, PEEK

Principal dimensions in mm

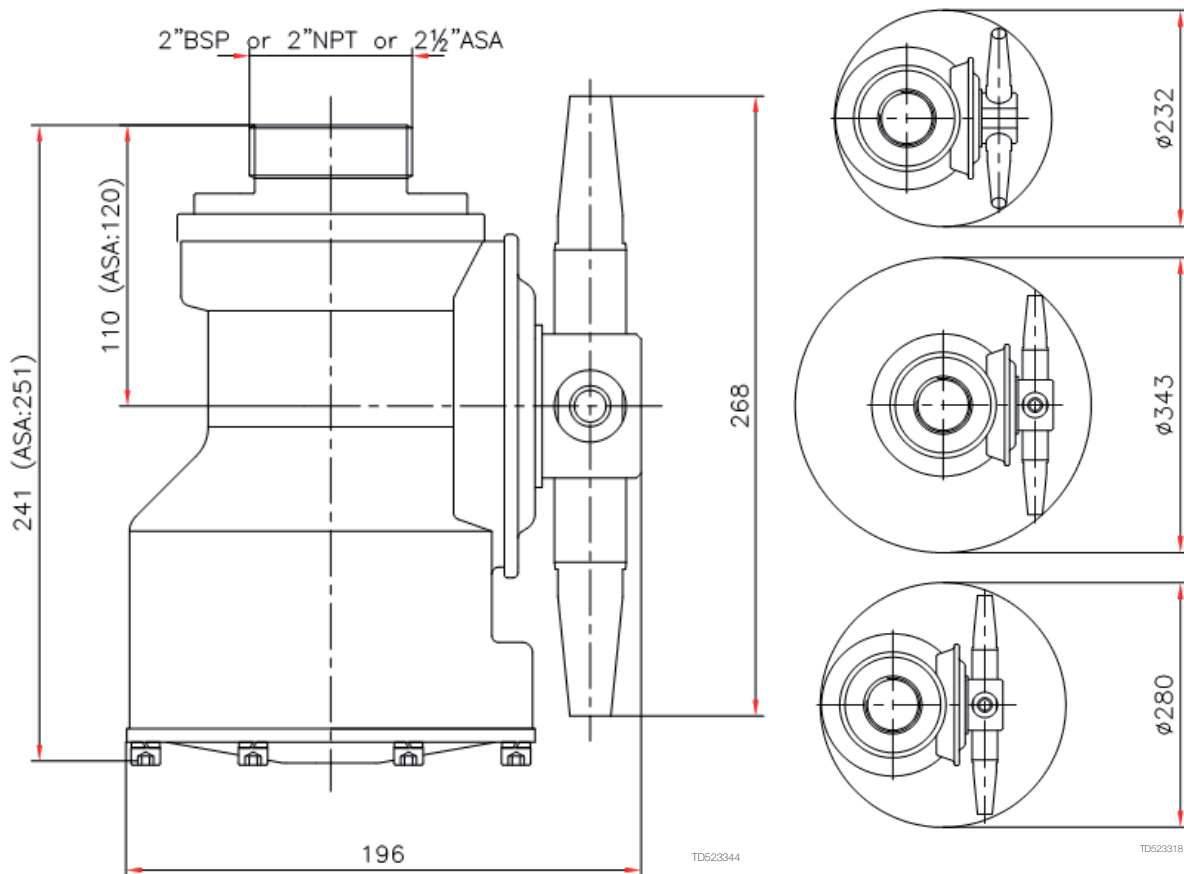

8 Technical Data

Flow rate

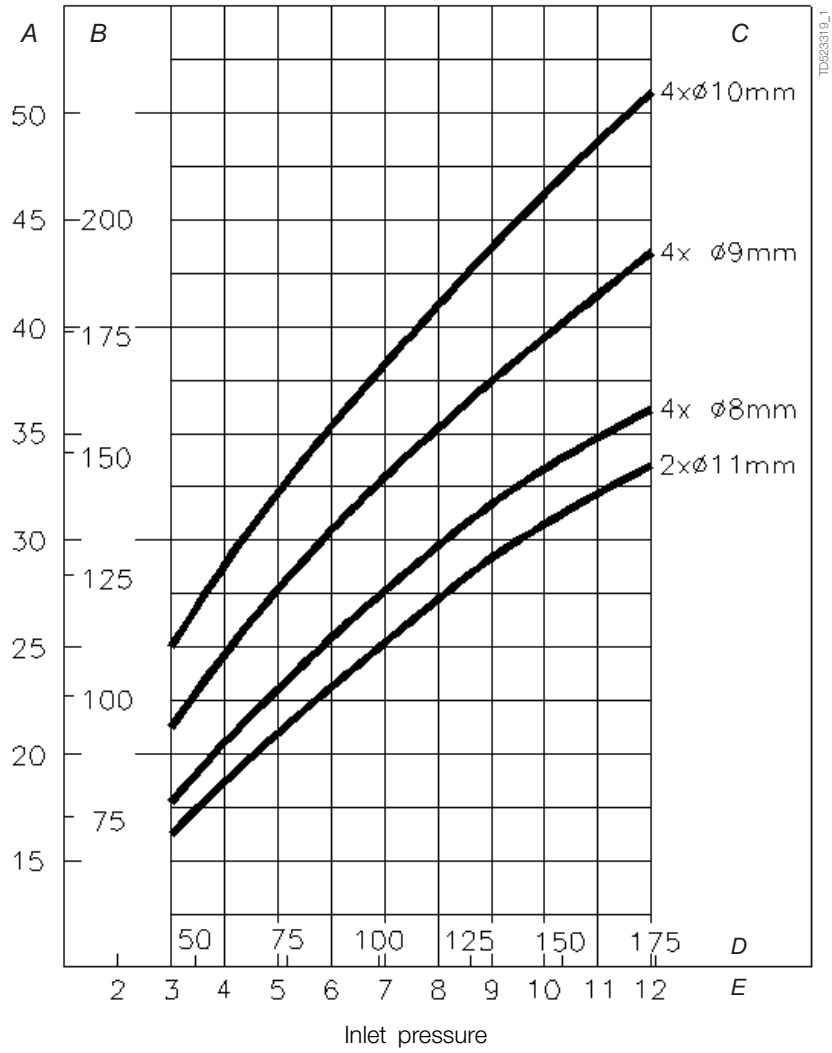

A: m ³ /h	B: USgpm	C: nozzle sizes	D: psi	E: bar
----------------------	----------	-----------------	--------	--------

Throw length

 Max. static
 Effective
TD523321

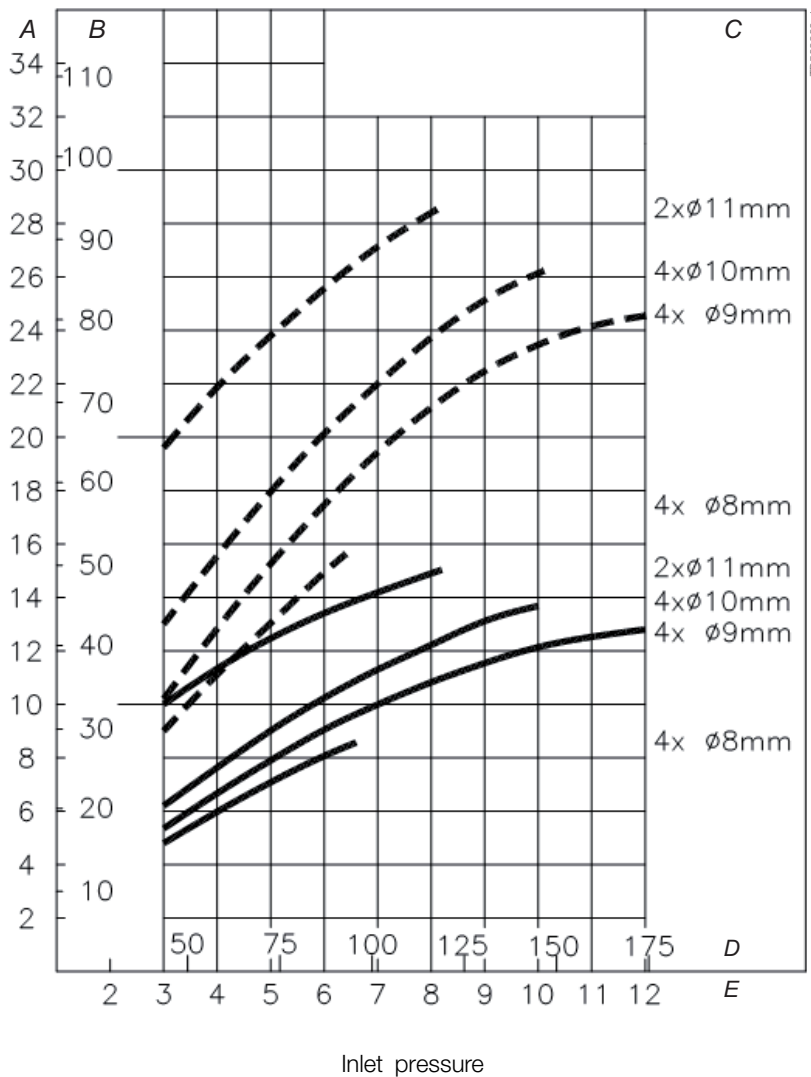

A: m	B: ft	C: nozzle sizes	D: psi	E: bar
------	-------	-----------------	--------	--------

Note: Throw lengths are measured as horizontal throw length at static condition. Vertical throw length upwards is approx. 1/3 less.

Effective throw length is defined as impact centre of jet 250 mm water column (50 lbs/sq.ft). Effective throw length varies depending on jet transverse speed over surface, substance to be removed, cleaning procedure and agent.

The inlet pressure has been taken immediately before the machine inlet. In order to achieve the performance indicated in the curves, the pressure drop in the supply lines between pump and machine must be taken into consideration.

8 Technical Data

Cleaning Time, f. complete Pattern (= 8 cycles)

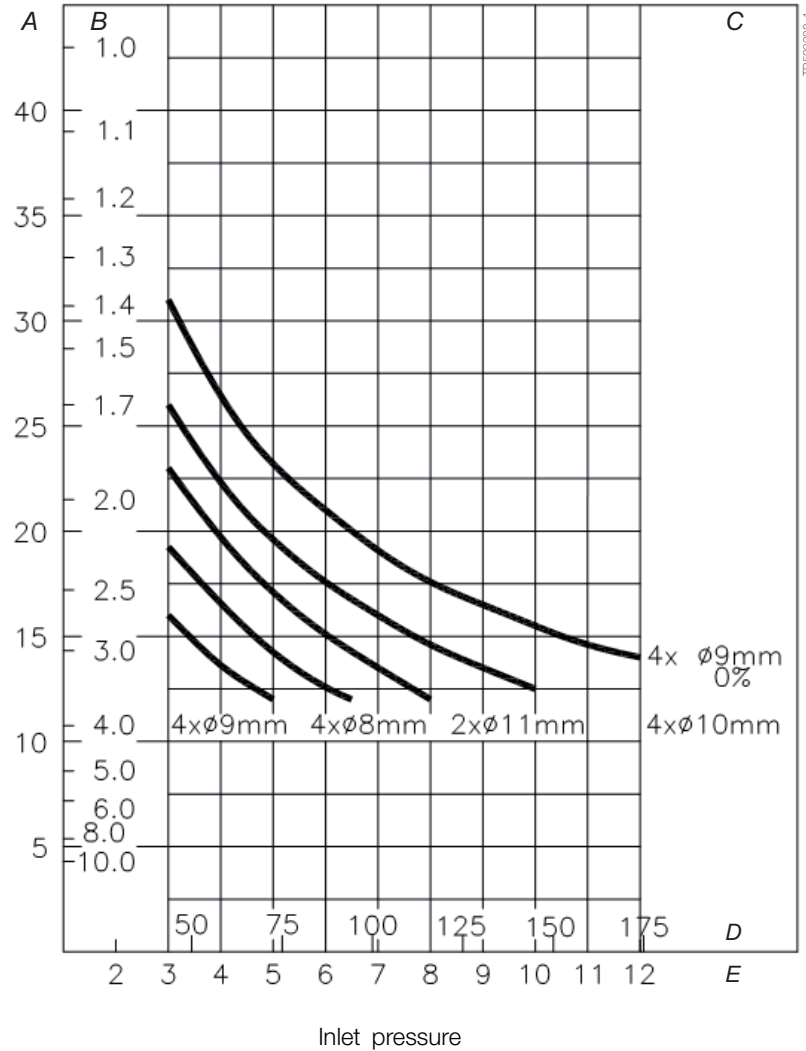

A: min.	B: RPM of machine body	C: nozzle sizes	D: psi	E: bar
---------	------------------------	-----------------	--------	--------

9.1 Standard Configurations

Connection	Turbine/ Inlet Guide	Nozzles (mm) (3/4" thread conn.)	Article No.
<u>Nipple:</u> 2" NPT, Male di: ø44mm	100%	4 x ø8	TE22C110
		4 x ø9	TE22C112
	0%	4 x ø9	TE22C130
		4 x ø10	TE22C132
<u>Nipple:</u> 2" ASA-B-26	100%	4 x ø8	TE22C260
		4 x ø9	TE22C262
	0%	4 x ø9	TE22C280
		4 x ø10	TE22C282
<u>Nipple:</u> 2" BSP, Male di: ø44mm	100%	4 x ø8	TE22C210
		4 x ø9	TE22C212
	0%	4 x ø09	TE22C230
		4 x ø10	TE22C232

The machine is equipped with a clutch in the hub, which gives the possibility of rotation by hand the nozzles, when the machine is to be lifted out through a tank opening.

9.2 Standard options

Machines with PEEK wear parts

Connection	Turbine/ Inlet Guide	Nozzles (mm) (3/4" thread conn.)	Article No.
<u>Nipple:</u> di: ø44mm, 2" NPT, Male	100%	4 x ø8	TE22C110-06
		4 x ø9	TE22C112-06
	0%	4 x ø9	TE22C130-06
		4 x ø10	TE22C132-06
<u>Nipple:</u> di: ø44mm, 2" BSP, Male	100%	4 x ø8	TE22C210-06
		4 x ø9	TE22C212-06
	0%	4 x ø9	TE22C230-06
		4 x ø10	TE22C232-06

9 Product Programme

9.3 Available add-ons

- ATEX, category 1 for installation in zone 0/20

Standard machines: TE22CXXX-70 ATEX

Standard option, Machine with PEEK wear parts: TE22CXXX-76 ATEX with PEEK wear parts*

*Note: Not available for 2xø11 mm nozzles

Explanation to Add-ons

ATEX, category 1 for installation in zone 0/20 in accordance with Directive 94/9/EC. valid until 2016-04-19/Directive 2014/34/EU valid from 2016-04-20.

10 Parts List and Drawing, Service Kits and Tools

10.1 Reference List of Parts TZ-66

Pos.	Ref. No.	No./Unit	Description	Material	Remarks
1	# TE22B500	1	Nipple 2" BSP	Stainless steel	Spare part
	# TE22B501	1	Nipple 2" NPT	Stainless steel	Spare part
	# TE22B502	1	Nipple 2½" ASA-B26	Stainless steel	Spare part
2	# TE603	1	Guide 100%	Stainless steel	Spare part
	# TE103-0	1	Guide ring 0%	Stainless steel	Spare part
3	TE604Z	1	Stem	Stainless steel	Spare part
3.1	TE904-1*)	1	Top liner	Polymer	Wear part
3.2	TEB604-2*)	1	Bottom liner	Polymer	Wear part
4	TE605	1	Impeller 100%	Stainless steel	Spare part
5	TE608Z	1	Gland	Stainless steel	Spare part
6	# TE609P	1	Main bush	Polymer	Wear part
	# TE22B575	1	Main bush	Polymer	Wear part
7	TE911K	1	Turbine shaft	Stainless steel	Wear part
8	TE512-13	1	Gear wheel w. ball race	Stainless steel	Spare part
8.1	TE126-1	(1)	Ball race	Stainless steel	Wear part
10	TE120	14	Screw	Stainless steel	Spare part
11	TE114	1	Pinion	Stainless steel	Spare part
12	TE615K	3	Collar bush	Carbon	Wear part
	TE22A585	3	Collar bush	Polymer	Wear part
13	TE22A360	1	Worm wheel w. reinforcem.	Polymer/Stainless steel	Wear part
	# TE22A365	1	Worm wheel w. reinforcem.	Polymer	Wear part
14	# TE22A360	1	Worm wheel w. reinforcem.	Polymer/Stainless steel	Wear part
	# TE22A365	1	Worm wheel w. reinforcem.	Polymer	Wear part
15	TE117	1	Journal	Stainless steel	Spare part
16	TE156	21	Spring washer	Stainless steel	Spare part
17	TE118	29	Screw	Stainless steel	Spare part
18	TE619A	4	Washer	Stainless steel	Spare part
19	TE101G	1	Handle 2"	Bronze	Spare part
20	TE622S	1	Bevel gear w. ball race	Stainless steel	Spare part
20.1	TE126-1	(1)	Ball race	Stainless steel	Wear part
21	TE22B340	1	Hub cover with ball race	Stainless steel	Spare part
21.1	TE126-1	(1)	Ball race	Stainless steel	Wear part
22	# TE50B008	4	Nozzle, ø8	Stainless steel	Spare part
	# TE50B009	4	Nozzle, ø9	Stainless steel	Spare part
	# TE50B010	4	Nozzle, ø10	Stainless steel	Spare part
	# TE50B011	2	Nozzle, ø11	Stainless steel	Spare part
22.1	TE50B000	2	Plug	Stainless steel	Spare part
23	TE624-4KZ	1	Hub	Stainless steel	Spare part
23.1	TE624-11*)	1	Hub liner	Polymer	Wear part
27	TE126S	2	Ball retainer with balls	Polymer/Stainless steel	Wear part
28	TE627Z	1	Body with bearings	Stainless steel	Not available
28.1	TE127Z1	(1)	Main collar upper	Stainless steel	Wear part
28.2	TE127Z2	(1)	Main collar lower	Stainless steel	Wear part
28.3	TE126-1	(1)	Ball race	Stainless steel	Wear part
28.4	TE127-3	(1)	Hub collar	Stainless steel	Wear part
29	TE128Z	1	Horizontal shaft	Stainless steel	Wear part
30	# TE929K	2	Slide bearing	Carbon	Wear part
	# TE22A570	2	Slide bearing	Polymer	Wear part
31	TE630	1	Gear frame	Stainless steel/Carbon	Spare part
32	TE531	2	Bearing cover	Stainless steel	Spare part
33	TE633-5	1	Bearing cover	Stainless steel	Spare part

Configuration according to delivery note/order confirmation.

Please note that some of the polymer parts are in PEEK, which is not resistant to concentrated sulfuric acid.

*) See remarks page 12.

10 Parts List and Drawing, Service Kits and Tools

10.2 Cross Sectional Drawing TZ-66

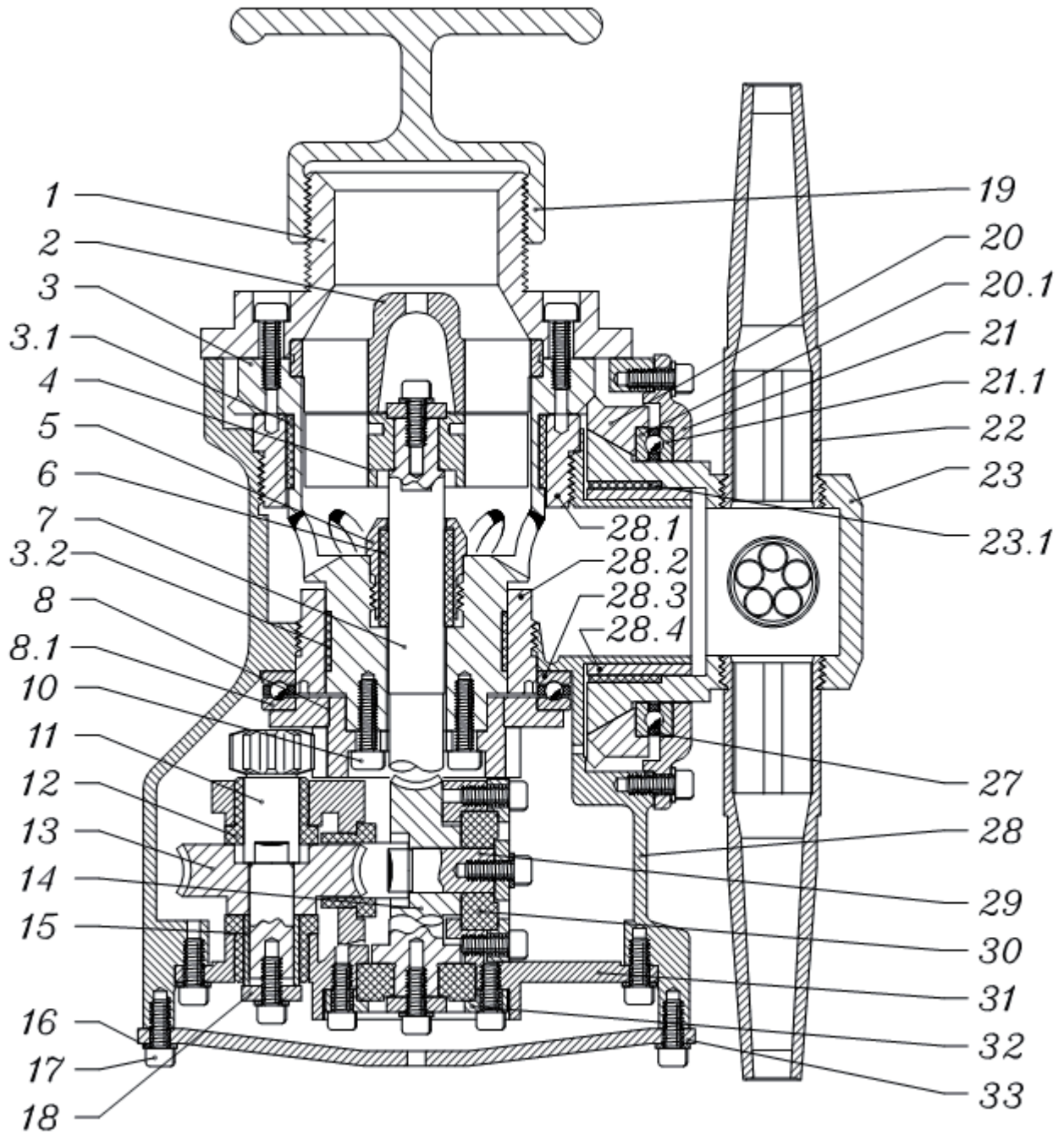

TD523348

10.3 Spare Parts Kits and Service Kits

Service Intervals

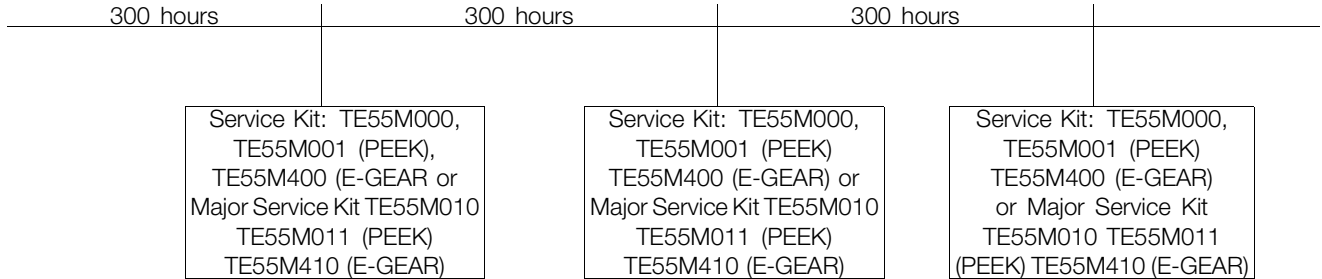

Standard Service Kit for Alfa Laval Toftejorg TZ-66, Article No. TE55M000

Part No.	Description	No.
TE22A360	Worm wheel w. reinforcement	2 pcs.
TE609P	Main bush	1 pcs.
TE615K	Collar bush	3 pcs.
TE651	Locking Wire	4 pcs.
TE929K	Slide bearing	2 pcs.

Service Kit Minor for Alfa Laval Toftejorg TZ-66 (PEEK), Article No. TE 55M001

Part No.	Description	No.
TE22B575	Main bush	1 cs.
TE22A585	Collar bush	3 pcs.
TE22A365	Worm wheel w. reinforcement	2 pcs.
TE651	Locking Wire	4 pcs.
TE22A570	Slide bearing	2 pcs.

Service Kit Minor for Alfa Laval Toftejorg TZ-66 (E-gear), Article No. TE55M400

Part No.	Description	No.
TE609P	Main bush	1 pcs.
TE615K	Collar bush	3 pcs.
TE22A360	Worm wheel w. reinforcement	1 pcs.
TE22A564	Worm wheel w. reinforcement, E-gear	1 pcs.
TE651	Locking Wire	4 pcs.
TE929K	Slide bearing	2 pcs.

10 Parts List and Drawing, Service Kits and Tools

Service Kit Major for Alfa Laval Toftejorg TZ-66, Article No. TE55M010

Part No.	Description	No.
TE911K	Turbine shaft	1 pcs.
TE126-1	Ball race	4 pcs.
TE624-11	Hub liner	1 pcs.
TE448	Cotter pin	1 pcs.
TE126S	Ball retainer w balls.	2 pcs.
TE127Z1	Main collar, upper	1 pcs.
TE127Z2	Main collar, lower	1 pcs.
TE127-3	Collar, hub	1 pcs.
TE128Z	Horizontal shaft	1 pcs.
TE55M000	Service Kit Minor	1 pcs.

Service Kit Major for Alfa Laval Toftejorg TZ-66 (PEEK), Article No. TE55M011

Part No.	Description	No.
TE911K	Turbine shaft	1 pcs.
TE126-1	Ball race	4 pcs.
TE624-11	Hub liner	1 pcs.
TE448	Cotter pin	1 pcs.
TE126S	Ball retainer w balls.	2 pcs.
TE127Z1	Main collar, upper	1 pcs.
TE127Z2	Main collar, lower	1 pcs.
TE127-3	Collar, hub	1 pcs.
TE128Z	Horizontal shaft	1 pcs.
TE55M001	Service Kit Minor	1 pcs.

Service Kit Major for Alfa Laval Toftejorg TZ-66 (E-gear), Article No. TE55M410

Part No.	Description	No.
TE911K	Turbine shaft	1 pcs.
TE126-1	Ball race	4 pcs.
TE624-11	Hub liner	1 pcs.
TE448	Cotter pin	1 pcs.
TE126S	Ball retainer w balls.	2 pcs.
TE127Z1	Main collar, upper	1 pcs.
TE127Z2	Main collar, lower	1 pcs.
TE127-3	Hub collar	1 pcs.
TE128E	Horizontal shaft	1 pcs.
TE55M400	Service Kit Minor	1 pcs.

10.4 Tools

Standard Tool kit for Toftejord TZ-66

Tool No.	Description	No.
TE134	Unbraco key for screw	1 pcs.
TE134A	Unbraco Screwdriver	1 pcs.
TE135	Unbraco key for screw	1 pcs.
TE135A	Unbraco screw driver	1 pcs.

Available on request:

Tool No.	Description
TE81B031	Pusher for 2" Gear frame
TE81B032	Fixture set f. Gear frame

Sketch of tools for replacement of Collars bush:

TE81B031: Pusher for Gear frame

TE81B032: Fixture set f. Gear frame

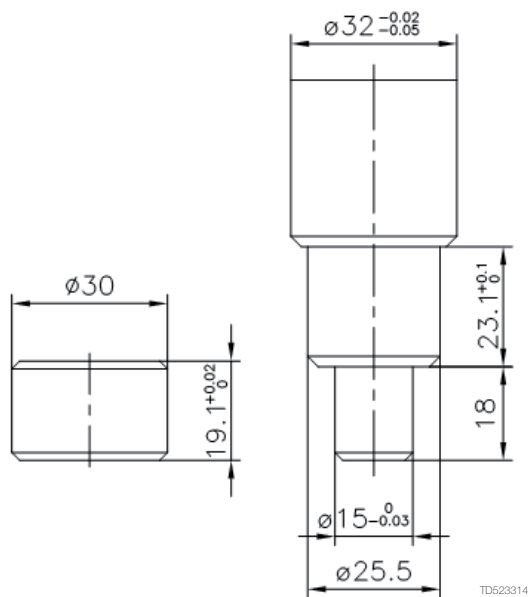
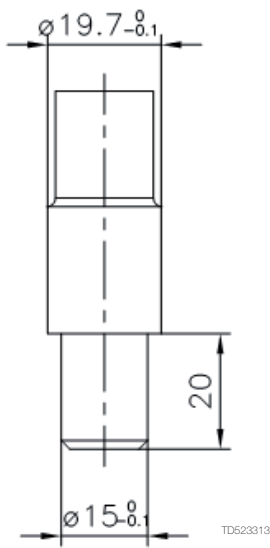

10 Parts List and Drawing, Service Kits and Tools

Sketch of tools for replacement of Main collars

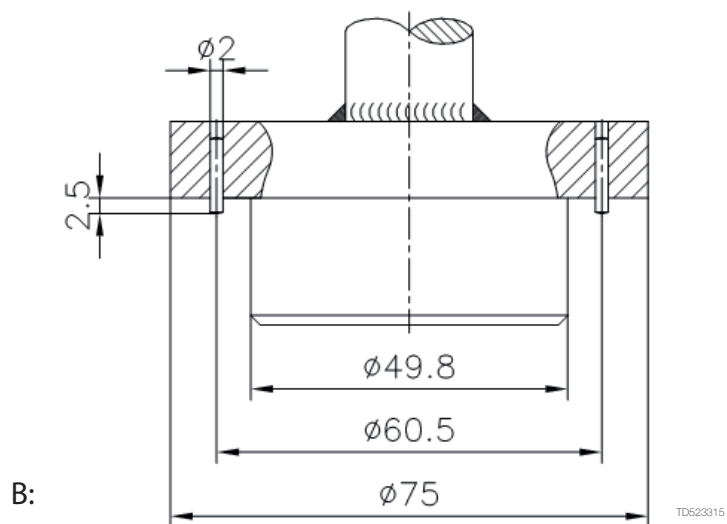
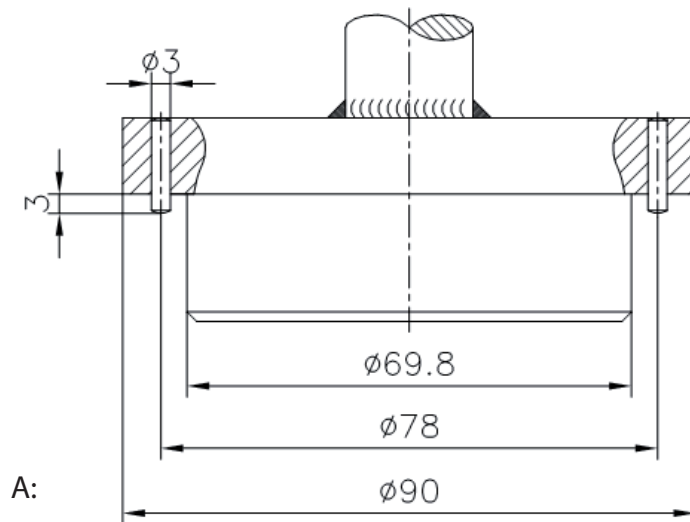

11.1 Service and Repair

Upon every return of a product, no matter if for modifications or repair, it is necessary to contact your local Alfa Laval office to guarantee a quick execution of your request.

You will receive instructions regarding the return procedure from your local Alfa Laval office. Be sure to follow the instructions closely.

11.2 How to Order Spare Parts

On the Cross Sectional Drawings as well as on all instruction drawings, the individual parts have a pos. No., which is the same on all drawings. From the pos. No. the part is easily identified in the Reference List of Parts, page 37.

Individual parts should always be ordered from the Reference List of Parts, page 37. Ref. No. and description should be clearly stated.

Please also quote the type of machine and serial No. This will help us to help you. The type and serial Nos. are stamped on the Body of the tank cleaning machine.

11.3 How to contact Alfa Laval Tank Equipment

For further information please feel free to contact:

Alfa Laval Tank Equipment

Alfa Laval Kolding A/S

31, Albuen - DK 6000 Kolding - Denmark

Registration number: 30938011

Tel switchboard: +45 79 32 22 00 - Fax switchboard: +45 79 32 25 80

www.toftejorg.com, www.alfalaval.dk - info.dk@alfalaval.com

Contact details for all countries are continually updated on our websites

How to contact Alfa Laval

Contact details for all countries are continually updated on our website.

Please visit www.alfalaval.com to access the information directly.

© Alfa Laval Corporate AB

This document and its contents is owned by Alfa Laval Corporate AB and protected by laws governing intellectual property and thereto related rights. It is the responsibility of the user of this document to comply with all applicable intellectual property laws. Without limiting any rights related to this document, no part of this document may be copied, reproduced or transmitted in any form or by any means (electronic, mechanical, photocopying, recording, or otherwise), or for any purpose, without the expressed permission of Alfa Laval Corporate AB. Alfa Laval Corporate AB will enforce its rights related to this document to the fullest extent of the law, including the seeking of criminal prosecution.