



KIESELMANN
FLUID PROCESS GROUP

Translation of the original

Operating instruction

KI-DS Single seat valves

Double-sealing single seat valve

Type: 5521

Type: 5522



Type: 5523

Type: 5524



KIESELMANN GmbH

Paul-Kieselmann-Str. 4-10
75438 Knittlingen

 +49(0) 7043 371-0 •  +49(0) 7043 371-125
www.kieselmann.de • info@kieselmann.de

Copyright: © KIESELMANN FLUID PROCESS GROUP

Table of contents

1	General informations	4
1.1	Informations for your safety	4
1.2	Marking of security instructions	4
1.3	General designated use	4
1.4	Personnel	4
1.5	Modifications, spare parts, accessories	5
1.6	General instructions	5
2	Safety instructions	6
2.1	Intended use	6
2.2	General notes	6
2.3	General safety instructions	6
3	Delivery, transport and storage	8
3.1	Delivery	8
3.2	Transport	8
3.3	Storage	8
4	Specification	9
4.1	Modular system	9
4.2	Valve types	9
5	Function and operation	10
5.1	Description of function	10
5.2	Valve basic position:	10
5.3	Control system and position indicator	11
5.4	Pneumatic valve activation	11
6	Commissioning, service and maintenance	12
6.1	Commissioning	12
6.1.1	Installation instructions	12
6.1.2	General welding guidelines	12
6.1.3	ATEX - Guidelines	12
6.2	Service	12
6.3	Cleaning	13
7	Technical data	14
7.1	Torques	14
7.2	Operating pressure	15
8	Disassembly and assembly	16
8.1	Disassembly	16
8.2	Assembly	19
9	Drawings and dimensions	21
9.1	Drawings	21
9.1.1	Double-sealing single seat valve	21
9.1.2	Pilot valves (Inlet- and outlet valve)	22
9.2	Control units	23
9.3	Dimensions	24
10	Wearing parts	25
10.1	Valve insert (VE)	25
10.2	Pilot valves (EV and AV)	26
10.3	Seal kit - in product contact	26
10.4	Seal kit complete	26
11	Classification	27
11.1	Structure of Order Number	27
12	Appendix	29
12.1	Declaration of incorporation	29

1 General informations

1.1 Informations for your safety

We are pleased that you have decided for a high-class KIESELMANN GmbH Guth Ventiltechnik GmbH product. With correct application and adequate maintenance, our products provide long time and reliable operation.





Before installation and initiation, please carefully read this instruction manual and the security advices contained in it. This guarantees reliable and safe operation of this product and your plant respectively. Please note that an incorrect application of the process components may lead to great material damages and personal injury.

In case of damages caused by non observance of this instruction manual, incorrect initiation, handling or external interference, guarantee and warranty will lapse!

Our products are produced, mounted and tested with high diligence. However, if there is still a reason for complaint, we will naturally try to give you entire satisfaction within the scope of our warranty. We will be at your disposal also after expiration of the warranty. In addition, you will also find all necessary instructions and spare part data for maintenance in this instruction manual. If you don't want to carry out the maintenance by yourself, our KIESELMANN GmbH Guth Ventiltechnik GmbH - service team will naturally be at your disposal.

1.2 Marking of security instructions

Hints are available in the chapter "safety instructions" or directly before the respective operation instruction. The hints are highlighted with a danger symbol and a signal word. Texts beside these symbols have to be read and adhered to by all means. Please continue with the text and with the handling at the valve only afterwards.

Symbol	Signal word	Meaning
	DANGER	Imminent danger which will result severe personal injury or death.
	WARNING	Imminent danger which may result severe personal injury or death.
	CAUTION	Dangerous situation which may cause slight personal injury or material damages.
	NOTICE	An harmful situation which may result in damages of the product itself or of adjacent vicinity.
	INFORMATION	Marks application hints and other information which is particularly useful.

1.3 General designated use

The fitting is designed exclusively for the purposes described below. Using the fitting for purposes other than those mentioned is considered contrary to its designated use. KIESELMANN GmbH Guth Ventiltechnik GmbH cannot be held liable for any damage resulting from such use. The risk of such misuse lies entirely with the user. The prerequisite for the reliable and safe operation of the fitting is proper transportation and storage as well as competent installation and assembly. Operating the fitting within the limits of its designated use also involves observing the operating, inspection and maintenance instructions.

1.4 Personnel

Personnel entrusted with the operation and maintenance of the tank safety system must have the suitable qualification to carry out their tasks. They must be informed about possible dangers and must understand and observe the safety instructions given in the relevant manual. Only allow qualified personnel to make electrical connections.

1.5 Modifications, spare parts, accessories

Unauthorized modifications, additions or conversions which affect the safety of the fitting are not permitted. Safety devices must not be bypassed, removed or made inactive. Only use original spare parts and accessories recommended by the manufacturer.

1.6 General instructions

The user is obliged to operate the fitting only when it is in good working order. In addition to the instructions given in the operating manual, please observe the relevant accident prevention regulations, generally accepted safety regulations, regulations effective in the country of installation, working and safety instructions effective in the user's plant.

2 Safety instructions

2.1 Intended use

The double sealing single seat valve is used as a pneumatically controlled shut-off valve in the beverage and food industry, in pharmaceutical, bio-engineering, as well as in chemical engineering.

2.2 General notes



NOTICE - observe the operating instructions

To avoid danger and damage, the fitting must be used in accordance with the safety instructions and technical data contained in the operating instructions.



NOTICE

All data are in line with the current state of development. Subject to change as a result of technical progress.

2.3 General safety instructions



WARNING

Risk of injury by moving parts

Do not grab into the valve when the actuator is pressurized. Limbs can be crushing or amputating.

- Remove the control air line before dismantling.
- Ensure that the actuator is unpressurized.



WARNING

Risk of injury by moving parts

When dismount the clamp coupling, the spring preloaded valve insert (air open - spring close) may incur serious injuries by jumping out of the housing.

- First pneumatically open the valve before disassembling the clamp coupling, so that up-stroke the piston.
- Dismount the valve insert.
- Remove the control air line at valve insert.

⇒ Ensure that the actuator is unpressurized.



WARNING

Risk of injury by outflowing medium

Dismantling the valve or valve assemblies from the plant can cause injuries.

- Medias flowing through the leakage drain outlet are to be drained off without splashing into a discharge arrangement.
- Carry the disassembling only if when the plant has been rendered pressure-less and free of liquid and gas.



WARNING

ATEX - Guidelines

If the valve or the plant is operated in a potentially explosive atmosphere, the valid ATEX directive of the EC and the installation instructions in this operating manual must be observed.

**⚠ CAUTION**

When mounting the clamps, the max. torque must not be exceeded.
(see technical data)

**⚠ CAUTION**

To avoid air leaking, only use pneumatic connection parts that have an O-ring seal facing the even surface.

**⚠ CAUTION**

Before starting the system, the entire pipeline system must be thoroughly cleaned.

**⚠ CAUTION**

Steps should be taken to ensure that no external forces are exerted on the fitting.

3 Delivery, transport and storage

3.1 Delivery

- Immediately after receipt check the delivery for completeness and transport damages.
- Remove the packaging from the product.
- Retain packaging material, or expose of according to local regulations.

3.2 Transport



CAUTION

Risk of injury and damage to the product

During the transport the generally acknowledged rules of technology, the national accident prevention regulations and company internal work and safety regulations must be observed.

3.3 Storage



NOTICE

Damage to the product due to improper storage!

Observe storage instructions
avoid a prolonged storage



INFORMATION

Recommendation for longer storage





We recommend regularly checking the product and the prevailing storage conditions during long storage times.



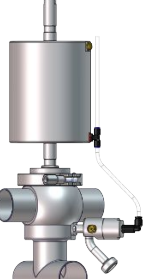

- To avoid damage to seals and bearings,
 - products up to DN 125 / OD 5 inch should be stored horizontally for maximum 6 months.
 - products larger than DN 125 / 5 inch, should be stored in the upright position with the actuator on top.
- Don't store any objects on the products.
- Protect the products for wetness, dust and dirt.
- The product should be stored in a dry and well ventilated room at a constant temperature (optimal indoor temperature: 25 C ±5 ; indoor humidity data 70% ±5%).
- Protect seals, bearings and plastic parts for UV light and ozone.

4 Specification

4.1 Modular system

4.2 Valve types

1x Pilot valve (1x Outlet valve)			
Angle valve Type 5521	t-valve Type 5522	cross valve Type 5523	Loop valve Type 5524
			
S - S	SS - S	SS - SS	S - SS

2x Pilot valve (1x Outlet valve, 1x Inlet valve)			
Angle valve Type 5521	t-valve Type 5522	cross valve Type 5523	Loop valve Type 5524
			
S - S	SS - S	SS - SS	S - SS

5 Function and operation

5.1 Description of function

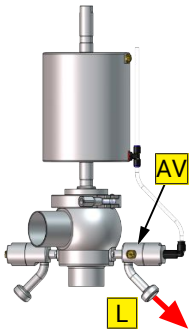

Valve function:	<ul style="list-style-type: none"> The sealing function in the closed position is performed statically. Any leaks occurring due to damaged valve plate seals are drained to the exterior without pressure via the leakage discharge (L) at the outlet valve (AV).
Operation:	<ul style="list-style-type: none"> pneumatic operation by a lift drive (air/spring)
Activation:	<ul style="list-style-type: none"> Pneumatically over a 3/2-way solenoid valve (see Pneumatic valve activation [▶ 11])

Description of function - Lift actuator

Normally closed (NC) Basic position: Valve close	
pneum. operated	→ opens the valve
<u>undivided</u> pneum. operated	→ spring force closes the valve
pneum. operated	→ valve "CLOSE"
<u>undivided</u> pneum. operated	→ spring force opens the valve

5.2 Valve basic position:

Basic position:	Valve closed	Valve open
Kind of actuation:	Normally closed (NC)	Normally open (NO)
Angle valve Type: 5521 S-S	 Line A - B closed	 Line A - B open
t-valve Type: 5522 SS-S	 Line A - B closed	 Line A - B open
cross valve Type: 5523 SS-SS	 Line A - B closed	 Line A - B open
Loop valve Type: 5524 S-SS	 Line A - B closed	 Line A - B open

5.3 Control system and position indicator



Feedback unit -optional-

Optionally, modular valve control head systems can be installed to the actuator for reading and actuating valve positions. The standard version is a closed system with SPS or ASI-bus switch-on electronics, and integrated 3/2-way solenoid valves. For tough operating conditions we recommend employing a high-grade steel cover.



Feedback unit with finger guard -optional-

For the acquisition of the valve positions over inductive initiators (Sensors), a feedback unit is mounted on the actuation. The enquiry takes place over the position of the piston rod.

5.4 Pneumatic valve activation

Antriebsart: normal closed (NC)		
Valve OPEN by pressurised air	control air feed P → MV1 → P1/LA2	control air feed ext. MV → LA2
Valve CLOSED by spring tension	de-aeration LA2/P1 → MV1 → R	de-aeration LA2 → ext. MV

Kind of actuator: normal open (NO)		
Valve OPEN by spring tension	de-aeration P1/LA1 → MV1 → R	de-aeration LA1 → ext. MV
Valve CLOSED by pressurised air	control air feed P → MV1 → P1/LA1	control air feed ext. MV → LA1

- MV = solenoid valve
- R = de-aeration, sound absorber
- P = compressed-air inlet
- LA = air supply
- S = Slide switch for manual operation of the solenoid valve
- Si = Sensor inductive
- E = sensor mounting

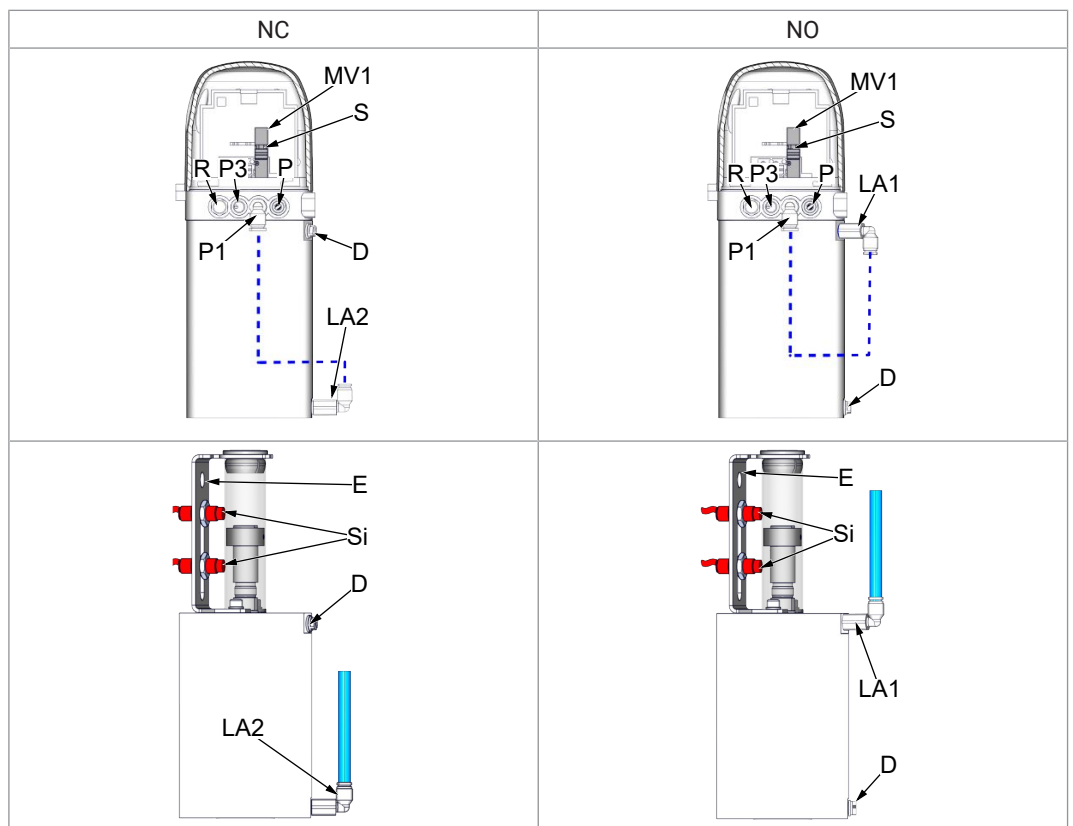

6 Commissioning, service and maintenance

6.1 Commissioning

6.1.1 Installation instructions

Fitting position

The valve must be installed vertically with the actuator at the upwards. Liquid must be able to flow freely from the valve housing.

6.1.2 General welding guidelines

Sealing elements integrated in weld components must generally be removed prior to welding. To prevent damage, welding should be undertaken by certified personnel (EN ISO 9606-1). Use the TIG (Tungsten Inert Gas) welding process.



⚠ CAUTION

Damage and injuries due to high temperature supply

To avoid a distortion of the components, all welding parts must be welded to stress-relieved. Allow all components to cool before assembling.



! NOTICE

Damage due to impurities

Impurities can cause damage to the seals and seals area. Clean inside areas prior to assembly.

6.1.3 ATEX - Guidelines

For valves or plants/installations that are operated in the ATEX area, sufficient bonding (grounding) must be ensured (see valid ATEX Guidelines EG).

6.2 Service



RECOMMENDATION

Replacement of seals

To achieve optimal maintenance cycles, the following points must be observed!

- When replacement of seals, all product-contacting seals should be replaced.
- Only original spare parts may be installed.

Maintenance interval

The maintenance intervals depend on the operating conditions "temperature, temperature-intervals, medium, cleaning medium, pressure and opening frequency". We recommend replacing the seals 1-year cycle. The user, however should establish appropriate maintenance intervals according to the condition of the seals.

Lubricant recommendation

i	EPDM; HNBR; NBR; FKM; k-flex	-	Klüber Paraliq GTE703*
	Silicone	-	Klüber Sintheso pro AA2*
	Thread	-	Interflon Food*
<p>*) It is only permitted to use approved lubricants, if the respective fitting is used for the production of food or drink. Please observe the relevant safety data sheets of the manufacturers of lubricants.</p>			

Maintenance - Lift actuator

The actuator is maintenance-free and non-removable.

6.3 Cleaning

Cleaning

Ideally, cleaning is carried out with pipe system cleaning when the valve is open.

Through the inlet valve (EV), the leakage area between the piston seals can be cleaned or steam-cleaned in observance of the technical data.

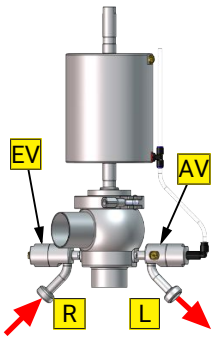

7 Technical data

Model:	KI-DS Double-sealing single seat valve pneumatic operation	
Valve size:	DIN: DN25 - DN100 Inch: 1" - 4"	
Connections:	weld-on end DIN EN 10357	
Temperature range:	Ambient temperature:	+4 to +45°C (air)
	Operating temperature:	+0 to +95°C (medium dependent)
	Sterilization temperature:	EPDM +140°C (SIP 30 min) HNBR +120°C (SIP 30 min)
Pressure nominal (bar):	PN16	
Leak rate:	A (DIN EN 12266-1)	
Control air:	<u>Control air pressure:</u>	<u>Quality of control air:</u>
to DN 65 / 2½	5,5 - 8,0 bar	ISO 8573-1 : 2001 quality class 3
from DN 80 / 3"	6,0 - 8,0 bar	
Materials: (in product contact)	Stainless steel:	1.4404 / AISI316L
	Surfaces:	Ra < 0,8µm metallic bright, e-polished
	Sealing material:	EPDM (FDA) HNBR (FDA)

7.1 Torques

Torques

DN	25	40	50	65	80	100
Inch	1	1½	2	2½	3	4
Clamp coupling (Nm):	15	15	15	25	25	55

7.2 Operating pressure

Operating pressure for valves with pneumatic operating



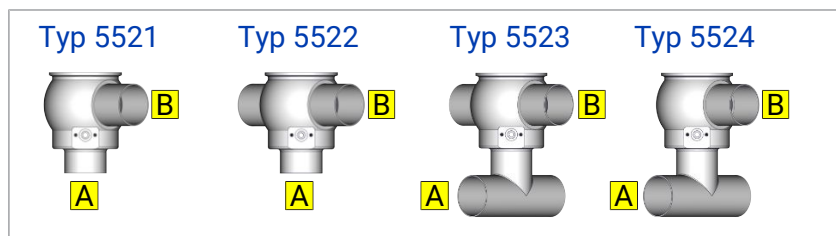

Nominal diameter	stroke	Operating direction	Opening pressures / closing pressures [bar]								KVS	
			Size of actuator (ØA)								A → B	B → A
			ø104		ø129		ø167		ø230			
mm		A	B	A	B	A	B	A	B	m³/h	m³/h	
DN 25	12.0	NC ↓	16.0	16.0	-	-	-	-	-	-	18.2	16.3
		NO ↑	-	-	-	-	-	-	-	-		
DN 40	24	NC ↓	9.5	12.0	12.4	16,0	15.0	16,0	-	-	35.7	32.7
		NO ↑	-	-	-	-	-	-	-	-		
DN 50	24.5	NC ↓	-	-	8.0	8.0	16,0	16,0	-	-	77.8	71.2
		NO ↑	-	-	-	-	-	-	-	-		
DN 65	24.0	NC ↓	-	-	4.5	8.0	11.7	12.4	16.0	16.0	130	124
		NO ↑	-	-	-	-	-	-	-	-		
DN 80	28.5	NC ↓	-	-	5.5	5.3	9.0	8.7	11.0	16,0	180	190
		NO ↑	-	-	-	-	-	-	-	-		
DN 100	28.5	NC ↓	-	-	-	-	4.5	5.6	6.8	12.7	246	269
		NO ↑	-	-	-	-	-	-	-	-		
OD 1"	8.0	NC ↓	16.0	16.0	-	-	-	-	-	-	18.2	16.3
		NO ↑	-	-	-	-	-	-	-	-		
OD 1½"	20.5	NC ↓	9.5	12.0	12.4	16,0	15.0	16,0	-	-	35.7	32.7
		NO ↑	-	-	-	-	-	-	-	-		
OD 2"	21.5	NC ↓	-	-	8.0	8.0	16,0	16,0	-	-	77.8	71.2
		NO ↑	-	-	-	-	-	-	-	-		
OD 2½"	18.0	NC ↓	-	-	4.5	8.0	11.7	12.4	16.0	16.0	130	124
		NO ↑	-	-	-	-	-	-	-	-		
OD 3"	28.5	NC ↓	-	-	5.5	5.3	9.0	8.7	11.0	16,0	180	190
		NO ↑	-	-	-	-	-	-	-	-		
OD 4"	26.0	NC ↓	-	-	-	-	4.5	5.6	6.8	12.7	246	269
		NO ↑	-	-	-	-	-	-	-	-		

Table 1 *) Control air pressure: 5,5 bar



8 Disassembly and assembly

8.1 Disassembly

T1		Combination wrench-Set	SW 8 - SW 24	-
T10		Joint -pin wrench	Pin Ø6	8027000065-000
T11		Hinged hook wrench	-	8027000065-000
T12		Joint face wrench	Pin Ø6 40-80 MM	8028340080-000



NOTICE

All threaded joint have right-hand thread.

Unscrew and remove control air, steam resp. cleaning lines and electrical lines, complete feedback unit or control head.

Assembly valve insert

- Connect compressed air to LA2 and pressurize the actuator with air.
 - The piston retracts.

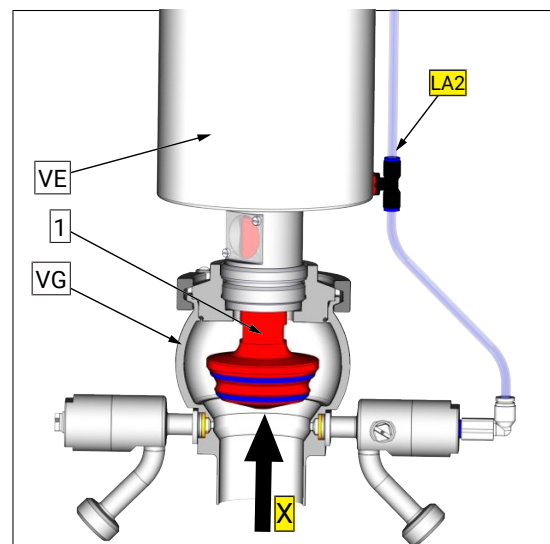

- Unscrew the clamp coupling (VK).
- Remove the complete valve insert with the upper shaft seal (D1) from the housing (VG).
- Disconnect compressed air at LA2 and depressurize the drive - The valve piston move in.
 - The valve piston returns to the basic position.
- Unscrew the screws (9) and remove the pilot valves EV and AV. Dismount seal (D6).

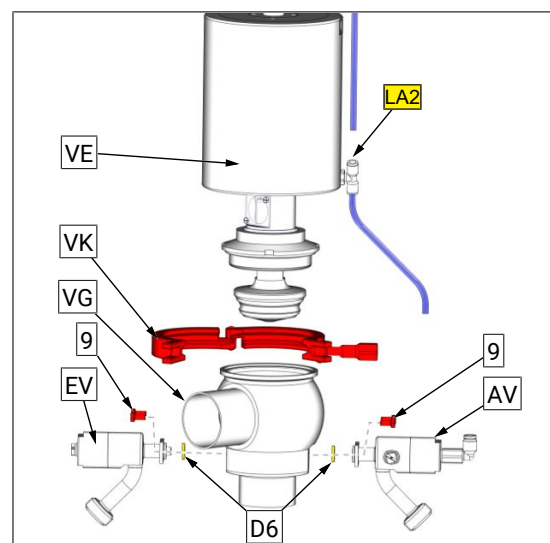

Replacement wear parts - Valve insert (VE)

- Unscrew the piston (1) from spindle (6) (SW1/SW2).
- Remove the O-ring (D2), (D1a) and (D1b).

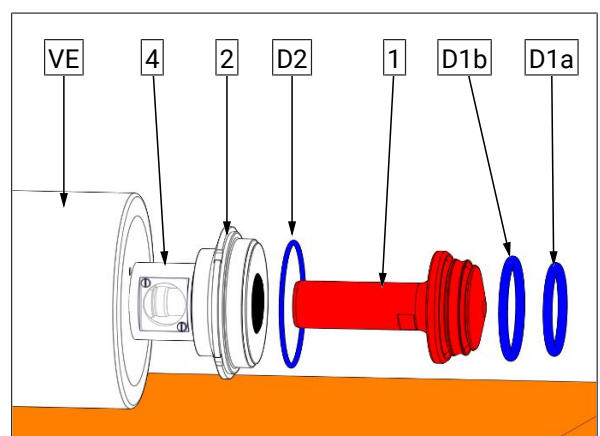
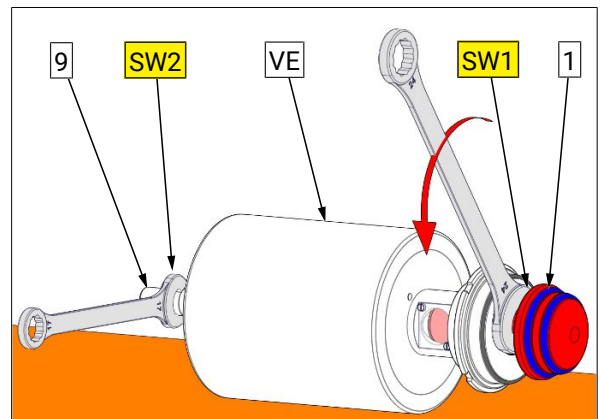

INFORMATION

Dismount O-ring

- Puncture the O-rings with a needle and remove them carefully from the groove.

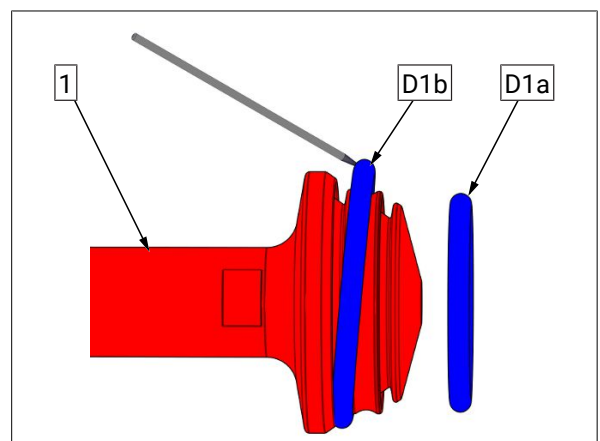

- Unscrew the insert (2) from the lantern (4) (use a hook wrench).
- Remove seal (D3).

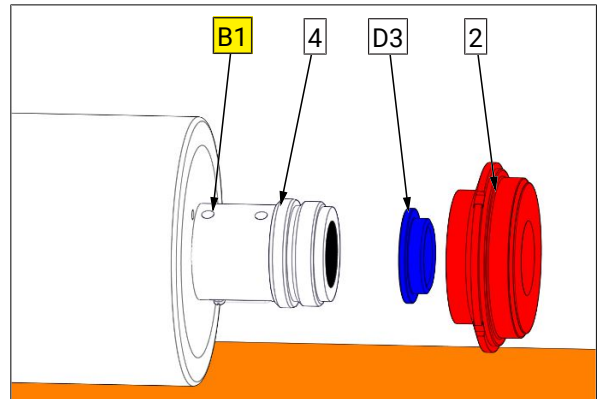
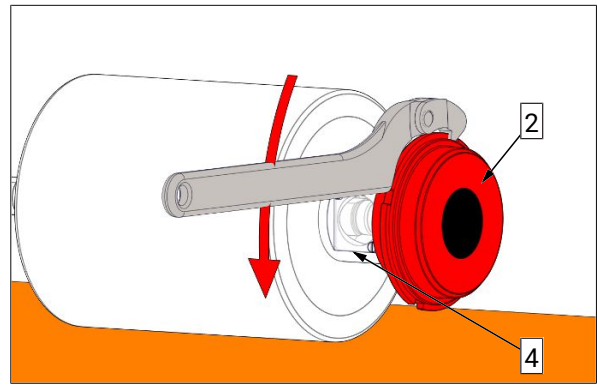

- Unscrew the lantern (4) from the actuator (7) (use a hook wrench).
- Unscrew the insert (8) from the actuator (7) (use a hook wrench).
- Remove the O-rings (D4) and (D5).

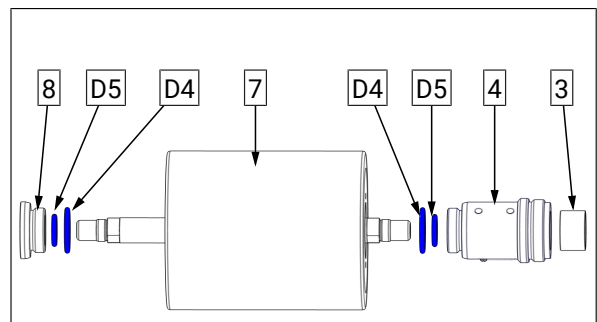
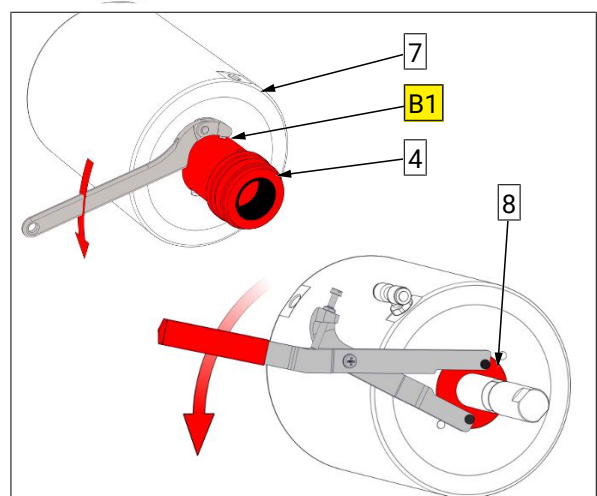

8.2 Assembly

- Before installation, thoroughly clean and slightly lubricate mounting areas and running surfaces.
- Assemble in reverse order.



NOTICE

Alternately press and roll the O-rings into the groove with round body.

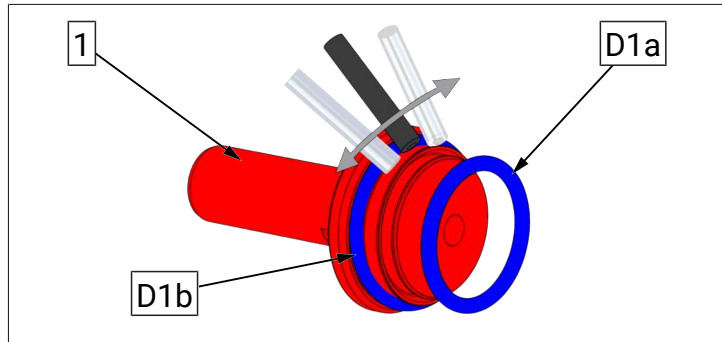

NOTICE

Mount the threaded connection (G1) with Screw retention detachable (e.g. Loctite 243) assembly.

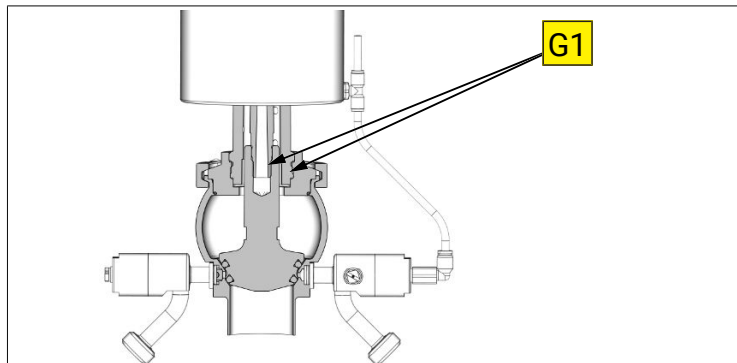

Performance test

- Check the function according to the specified performance data in the operating state.



NOTICE

During assembly, the following points must be observed!

Carefully fit in the complete valve insert into the casing. When fitting the valve insert and running surfaces onto the piston, do not damage.

➤ Mounting clamp coupling

- For mounting the clamp coupling, please note that it continuously fits form locking to the inclinations of the casing and the lantern/casing bottom.
- The centring of the retaining clamp during tightening can be accomplished with a slight beat (please use a soft-head hammer) on the extent of the retaining clamp.
- When tightening the clamp coupling, please pay attention to the turning moment and the gap size 'S' ($\leq 0,4\text{mm}$) between the components.
- Check valve functions by manually activating the 3/2-way solenoid valves after assembly!

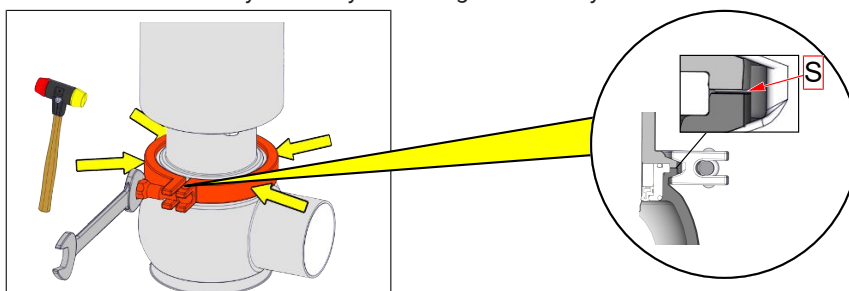

Torques

	DN	25	40	50	65	80	100
	Inch	1	1½	2	2½	3	4
Clamp coupling (Nm):		15	15	15	25	25	55

9 Drawings and dimensions

9.1 Drawings

9.1.1 Double-sealing single seat valve

- 1 = Piston
- 2 = Insert
- 3 = Bearing bush
- 4 = Lantern
- 5 = Bearing bush
- 6 = Spindle
- 7 = Pneum. actuator
- 8 = Insert - Lantern
- 9 = Set screw

- 11 = Spindle
- 12 = Bearing bush
- 13 = Scraper ring
- 14 = housing cover

- D1a = O-ring
- D1b = O-ring
- D2 = O-ring
- D3 = Shaft seal
- D4 = O-rings
- D5 = O-rings
- D6 = Seal

- B = Bore
- K = Cap
- AV = Outlet valve
- EV = Inlet valve
- VG = Valve housing
- VK = Clamp coupling

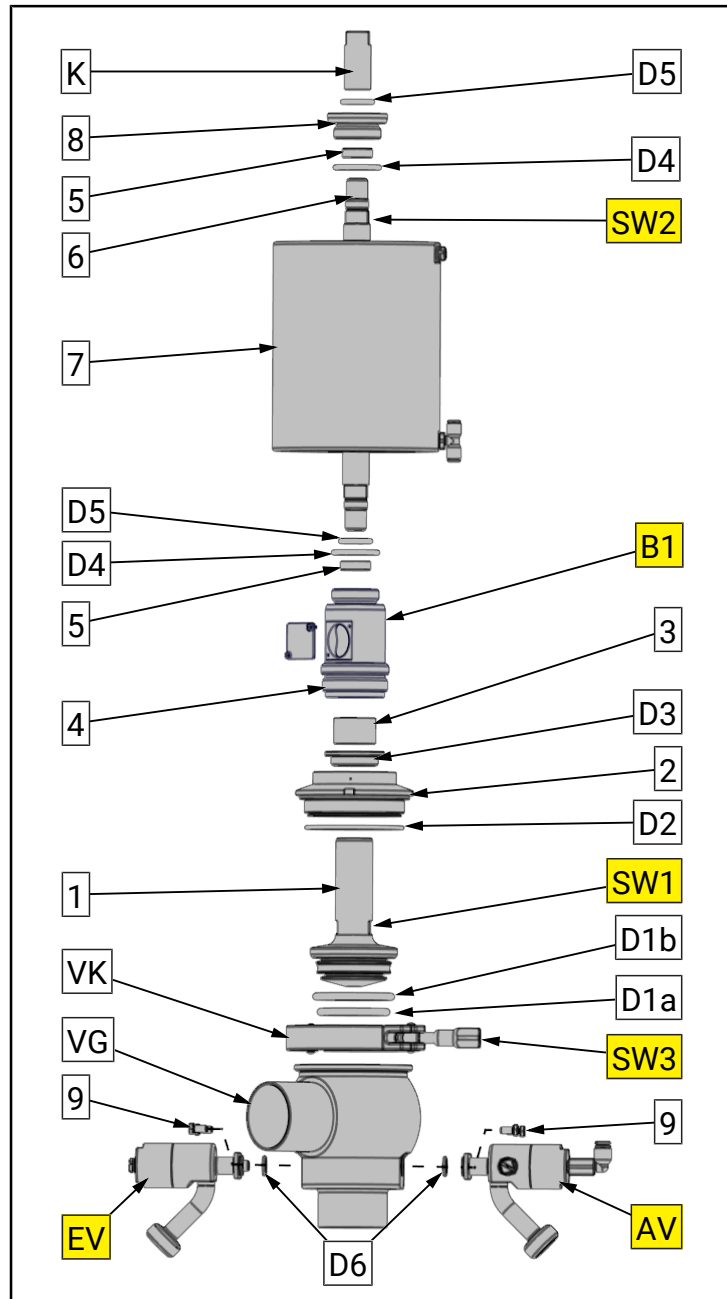

Nominal diameter	Wrench size		
	SW1	SW2	SW3
DN 25 / 1" - DN 100 / 4"	24	17	16

9.1.2 Pilot valves (Inlet- and outlet valve)

Inlet valve (EV)

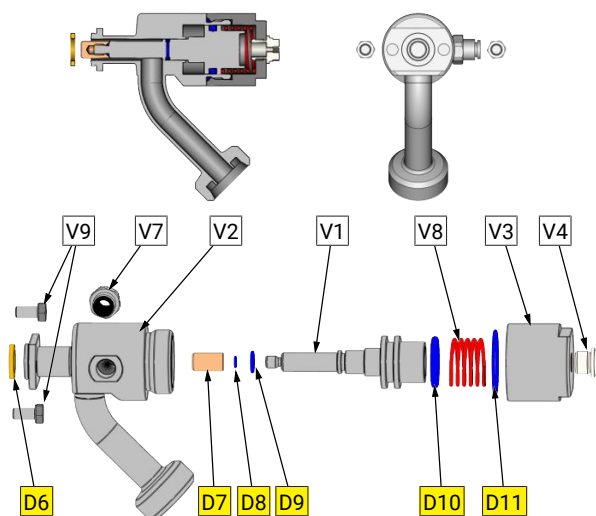

Outlet valve (AV)

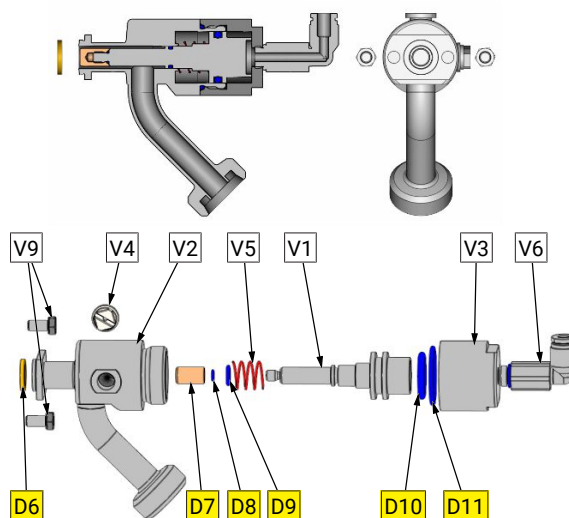

V1 Piston	V2 Housing	V3 housing cover
V4 screw plug	V5 Spring	V6 Push-in connector elbow
V7 Push-in connector straight	V8 Spring	V9 Screw
D6 Seal	D7 Piston	D8 O-ring
D9 O-ring	D10 O-ring	D11 O-ring

9.2 Control units

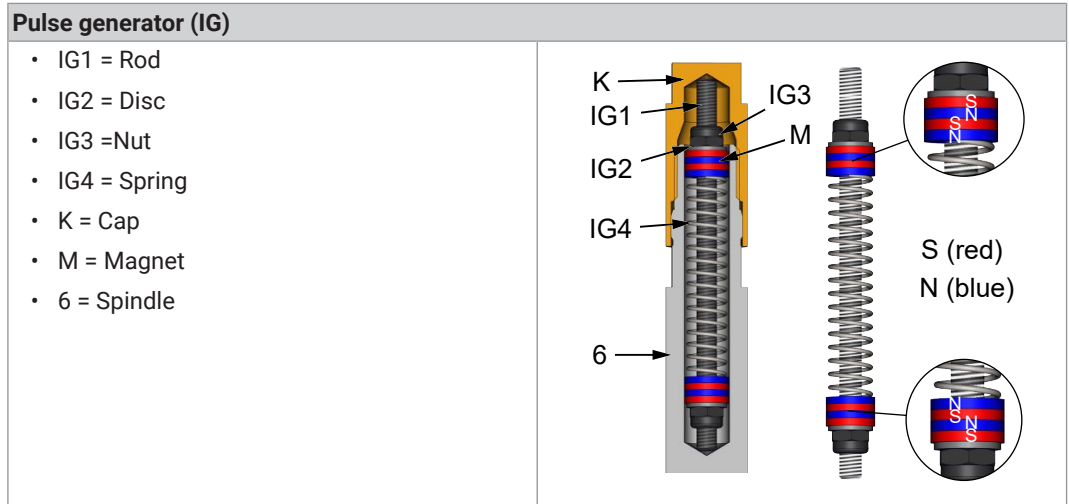
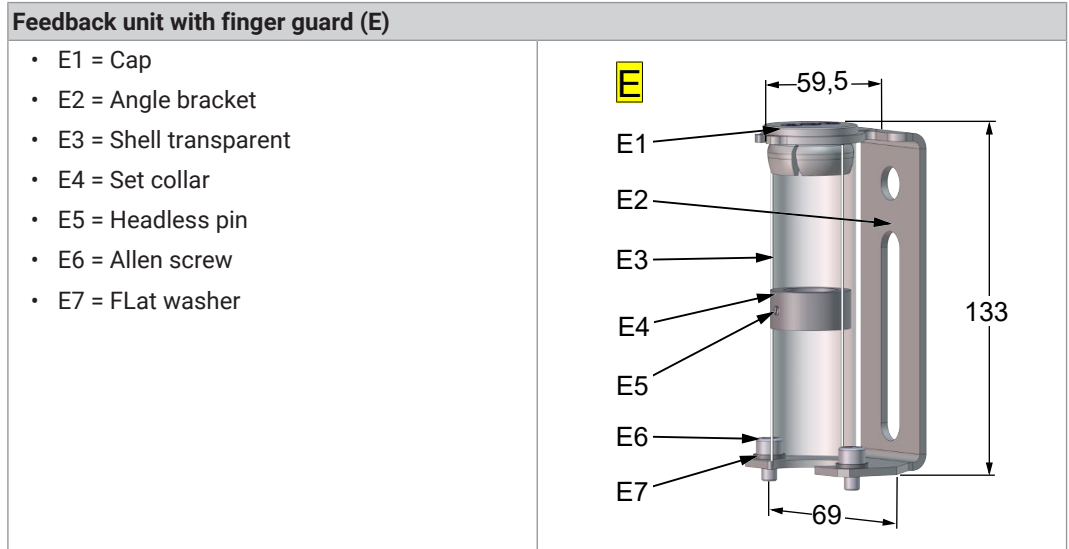
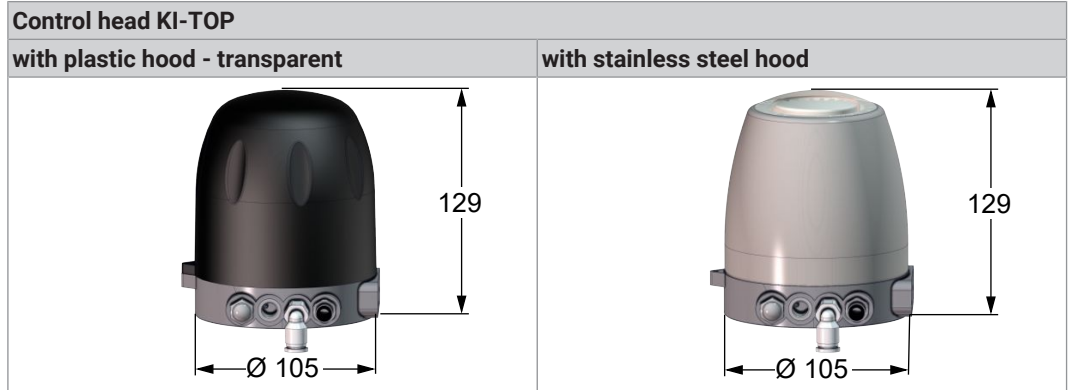

9.3 Dimensions

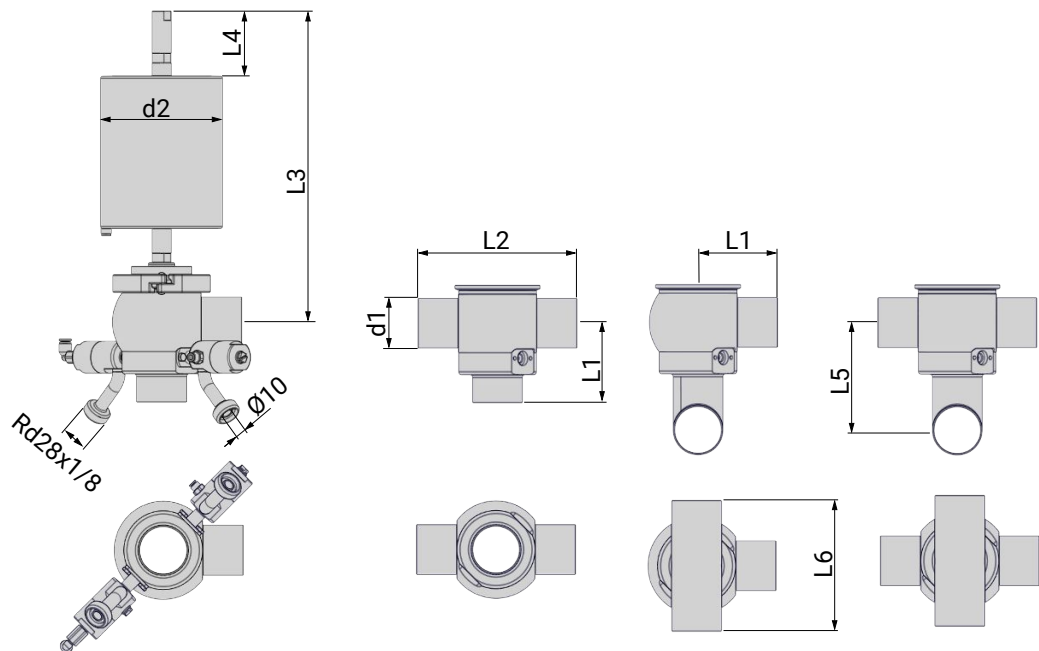

Nominal dia- meter	Dimensions [mm]							
	d1	L1	L2	L3	L4	L5	L6	L7
DN 25	29 x 1,5	75	150	330	81	91	100	275
DN 40	41 x 1,5	85	170	324	69	108	120	275
DN 50	53 x 1,5	85	170	330	69	115	140	268
DN 65	70 x 2,0	105	210	338	69	145	160	300
DN 80	85 x 2,0	115	230	341	64.5	162	180	318
DN 100	104 x 2,0	130	260	351	64.5	167	200	342
OD 1"	25,4 x 1,65	75	150	334	85	89	100	275
OD 1½"	38,1 x 1,65	85	170	326	72.5	105	120	275
OD 2"	50,8 x 1,65	85	170	322	71.5	112.5	140	268
OD 2½"	63,5 x 1,65	105	210	341	75	141	160	300
OD 3"	76,1 x 2,0	115	230	337	64.5	159	180	318
OD 4"	101,6 x 2,0	130	260	357	67	186	200	342

Valves that do not meet the catalogue standards, can lead to dimensional deviations.

1. Installation dimension M1 are incl. control head or feedback unit

10 Wearing parts

10.1 Valve insert (VE)

DN 25 - DN 50 / 1 Inch - 2 Inch

Pos.	Material	pce.	DN 25 1 Inch	DN 40 1½ Inch	DN 50 2 Inch
3	XSM	(1x)	Bearing bush 8050 028 020-156		
5	XMS	(2x)	Bearing 8500 020 007-156		
D1a	EPDM HNBR	(1x)	O-ring 2304 022 035-159	O-ring 2304 032 035-159	O-ring 2304 044 053-159
			2304 022 035-157	2304 032 035-157	2304 044 053-157
D1b	EPDM HNBR	(1x)	O-ring 2304 036 035-159	O-ring 2304 041 035-159	O-ring 2304 050 053-069
			2304 036 035-157	2304 041 035-157	2304 050 053-157
D2	EPDM HNBR	(1x)	O-ring 2304 069 026-159	O-ring 2304 069 026-159	O-ring 2304 069 026-159
			2304 069 028-050	2304 069 028-050	2304 069 028-050
D3	EPDM HNBR	(1x)	Shaft seal 5506 050 009-054	Shaft seal 5506 050 009-054	Shaft seal 5506 050 009-054
			5506 050 009-050	5506 050 009-050	5506 050 009-050
D4	NBR	(2x)	O-ring 2304 030 035-055		
D5	HNBR	(2x)	O-ring 2304 019 035-171		
D6	k-flex	(2x)	Seal 2353 015 010-114		

DN 65 - DN 100 / 2½ Inch - 4 Inch

Pos.	Material	pce.	DN 65 2½ Inch	DN 80 3 Inch	DN 100 4 Inch
3	XSM	(1x)	Bearing bush 8050 028 020-156		
5	XMS	(2x)	Bearing 8500 020 007-156		
D1a	EPDM HNBR	(1x)	O-ring 2304 053 053-159	O-ring 2304 069 053-159	O-ring 2304 088 053-159
			2304 053 053-157	2304 069 053-157	2304 088 053-157
D1b	EPDM HNBR	(1x)	O-ring 2304 069 053-159	O-ring 2304 079 053-170	O-ring 2304 098 053-170
			2304 069 053-157	2304 079 053-157	2304 098 053-157
D2	EPDM HNBR	(1x)	O-ring 2304 082 026-159	O-ring 2304 098 035-159	O-ring 2304 117 035-159
			2304 082 026-050	2304 098 035-050	2304 117 035-050
D3	EPDM HNBR	(1x)	Shaft seal 5506 050 009-054	Shaft seal 5506 050 009-054	Shaft seal 5506 050 009-054
			5506 050 009-050	5506 050 009-050	5506 050 009-050
D4	NBR	(2x)	O-ring 2304 030 035-055		
D5	HNBR	(2x)	O-ring 2304 019 035-171		
D6	k-flex	(2x)	Seal 2353 015 010-114		

10.2 Pilot valves (EV and AV)

Pos.	Material	pce.	Inlet valve (EV)	Outlet valve (AV)
			5522 150 050-041	5522 150 060-041
D7	k-flex	(1x)	Piston 5722 150 055-114	Piston 5522 150 055-114
D8	EPDM	(1x)	O-ring 2304 004 010-054	O-ring 2304 004 010-054
D9	EPDM	(1x)	O-ring 2304 007 015-159	O-ring 2304 007 015-159
D10	Viton	(1x)	O-ring 2304 017 030-055	O-ring 2304 017 030-055
D11	NBR	(1x)	O-ring 2304 024 020-055	O-ring 2304 024 020-055

10.3 Seal kit - in product contact

Seals (D1a), (D1b), (D2), (D3)

Material	DN 25	DN 40	DN 50
	1 Inch	1½ Inch	2 Inch
HNBR	5522 025 990-050	5522 040 990-050	5522 050 990-050
EPDM	5522 025 990-054	5522 040 990-054	5522 050 990-054

Material	DN 65	DN 80	DN 100
	2½ Inch	3 Inch	4 Inch
HNBR	5522 065 990-050	5522 080 990-050	5522 100 990-050
EPDM	5522 065 990-054	5522 080 990-054	5522 100 990-054

10.4 Seal kit complete

Seals (D1a), (D1b), (D2), (D3), (D6), (D7), (D8), (D9), (D10), (D11)

	DN 25	DN 40	DN 50
	1 Inch	1½ Inch	2 Inch
HNBR	5524 025 990-050	5524 040 990-050	5524 050 990-050
EPDM	5524 025 990-054	5524 040 990-054	5524 050 990-054

	DN 65	DN 80	DN 100
	2½ Inch	3 Inch	4 Inch
EPDM	5524 065 990-050	5524 080 990-050	5524 100 990-050
HNBR	5524 065 990-054	5524 080 990-054	5524 100 990-054

11 Classification

11.1 Structure of Order Number

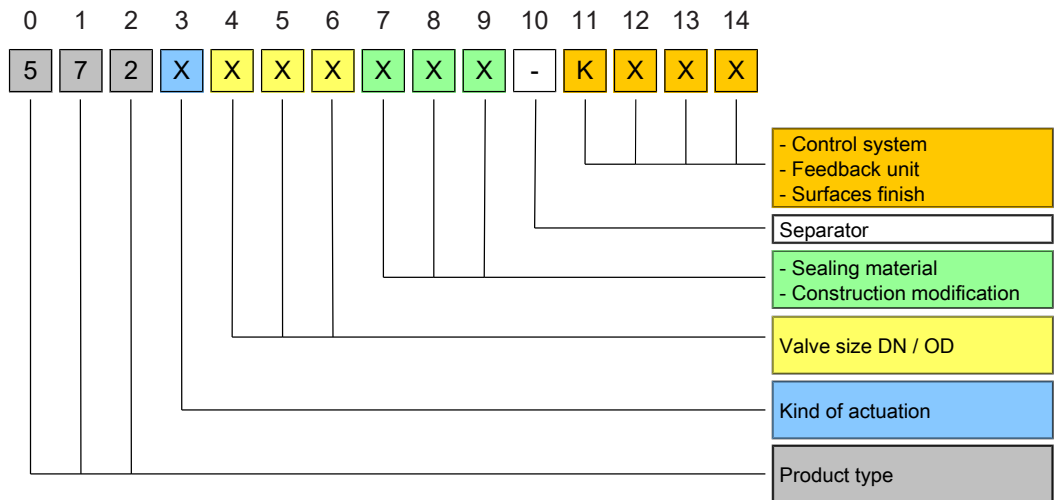

Product name 55x xxx xxx-xxxx

Type: 552x Double sealing single seat valves KI-DS

Housing type / Kind of actuation 55x xxx xxx-xxxx

Type	Housing type	Kind of actuation	2	3
5521	S-S Angle valve	pneumatical	2	1
5522	SS-S T-valve	pneumatical	2	2
5523	SS-SS Cross valve	pneumatical	2	3
5524	S-S-S Loop valve	pneumatical	2	4

Valve size DN/OD 55xx xxx xxx-xxxx

DN	4	5	6	OD	4	5	6
DN 25	0	2	5	OD 1"	0	2	6
DN 40	0	4	0	OD 1 1/2"	0	3	8
DN 50	0	5	0	OD 2"	0	5	1
DN 65	0	6	5	OD 2 1/2"	0	6	4
DN 80	0	8	0	OD 3"	0	7	6
DN 100	1	0	0	OD 4"	1	0	1
DN 125	1	2	5	OD 5"	1	2	7
DN 150	1	5	0	OD 6"	1	5	2

Material of seal & Design modification 55xx xxx xxx-xxxx

Material of seals & Design modifica			7	8	9
Kind of actuation	Pilot valves	Sealing material			
air open	with outlet valve	EPDM	0	3	0
		HNBR	0	3	5
spring close	with inlet- and Outlet valve	EPDM	1	3	0
		HNBR	1	3	5

Separator
- KIESELMANN Valve

55xx xxx xx-xxxx

Control system and position indication , External surface

55xx xxx xx-xxxx

Control system and position indicator	11	12	13	14
Control head SPS (old version)	5	x	x	
Control head ASi-Bus (old version)	6	x	x	
Control head KI-Top SPS	K	5	x	x
Control head KI-Top ASi-Bus	K	6	x	x

Feedback unit	11	12	13	14
Feedback unit with finger guard (5630 005 025-000)	7	5	0	

External surface	11	12	13	14
Valve without control system, External surface, AISI304, blank	0	2	0	
Valve without control system, External surface, AISI304, E-polished	0	2	1	
Valve without control system, External surface, AISI316L, E-polished	0	4	1	

12 Appendix

12.1 Declaration of incorporation



Declaration of incorporation

Translation of the original

Manufacturer / authorised representative:

KIESELMANN GmbH
Paul-Kieselmann-Str. 4-10
75438 Knittlingen
Germany

Authorised representative:
(for compiling technical documents)

Achim Kauselmann
Paul-Kieselmann-Str. 4-10
75438 Knittlingen
Germany

<u>Product name</u>	<u>Function</u>
pneum. Lift actuators	Stroke movement
pneum. Rotary actuators	Rotary movement
Ball valves	Media cutoff
Butterfly valves	Media cutoff
Single seat valves	Media cutoff
Flow control valves	Control of liquefied media
Throttle valve	Control of liquefied media
Overflow valve	Definition of fluid pressure
Double seat valve	Media separation
Bellow valves	Sampling of liquids
Sampling valves	Sampling of liquids
Two way valves	Media cutoff
Tankdome fitting	Prevention of overpressure and vacuum, Tank cleaning
Safety valve	Prevention of overpressure

The manufacturer hereby states that the above product is considered as an incomplete machine in the sense defined in the Directive 2006/42/EC on Machinery. The above product is exclusively intended to be installed into a machine or an incomplete machine. The said product does not yet conform to all the relevant requirements defined in the Directive on Machinery referred to above for this reason.

The specific technical documents listed in Appendix VII, Part B, have been prepared. The Authorized Agent empowered to compile technical documents may submit the relevant documents if such a request has been properly justified.

Commissioning of an incomplete machine must not only be carried out if it has been determined that the respective machine into which the incomplete machine is to be installed conforms to the regulations set out in the Directive on Machinery referred to above.

The above product conforms to the requirements of the directives and harmonized standards specified below:

- Directive 2014/68/EU
- DIN EN ISO 12100 Safety of machinery

Knittlingen, 21.07.2017

i.V. Uwe Heisswof
Head of Development