

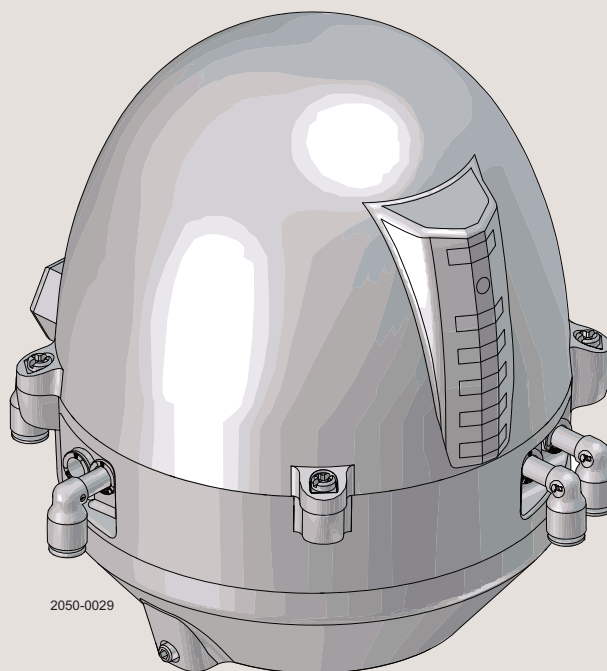

Instruction Manual

ThinkTop® Basic Intrinsically Safe



2050-0029

Registered Design
Registered Trademark

ESE00810-EN5 2016-06

Original manual



www.sks-online.com

The information herein is correct at the time of issue but may be subject to change without prior notice

1. EC Declaration of Conformity	4
2. Safety	5
2.1. Important information	5
2.2. Warning signs	5
2.3. Safety precautions	5
3. General information	6
3.1. ThinkTop Basic Intrinsically Safe at a glance	6
3.2. Recycling information	6
4. Technical specifications	7
5. Installation	8
5.1. Installation on air actuators	8
5.2. Air connections	10
5.3. Electrical connection, internal	11
6. Maintenance	12
6.1. Dismantling of ThinkTop Basic Intrinsically Safe	12
6.2. Assembly of ThinkTop Basic Intrinsically Safe	14
7. Parts list and service kits	16
7.1. Diagrams for ThinkTop Basic Intrinsically Safe	16
7.2. ThinkTop Basic Intrinsically Safe	18

1 EC Declaration of Conformity

The Designated Company

Alfa Laval Kolding A/S

Company Name

Albuen 31, DK-6000 Kolding, Denmark

Address

+45 79 32 22 00

Phone No.

hereby declare that

Top Unit for Valve Control and Indication

Designation

ThinkTop® Basic Intrinsically Safe

Type

is in conformity with the following directive with amendments:

- EMC Directive 2014/30/EU
- RoHS2 Directive 2011/65/EU

If the ThinkTop is ATEX marked it is in conformity with:

- Equipment Explosive Atmospheres (ATEX) Directive 2014/34/EC,

EN 1127-1:2011	Explosive atmospheres – Explosion prevention and protection Part 1: Basic concepts and methodology
EN 13463-1:2009	Non-electrical equipment for use in potentially explosive atmospheres Part 1: Basic method and requirements
EN 13463-5:2011	Non-electrical equipment intended for use in potentially explosive atmospheres Part 5: Protection by constructional safety 'c'
EN ISO 12100:2011	Safety of machinery - General principles for design - Risk assessment and risk reduction
DS/ISO/TR 14121-2:2012	Safety of machinery - Risk assessment Part 2: Practical guidance and examples of methods
EN 60079-11:2012	Explosive atmospheres Part 11: Equipment protection by intrinsic safety 'i' ("ia" eller "ib")

Intrinsically Safety

The electrical energy available in circuits and equipment, is limited to a level too low to ignite the most easily ignitable mixtures in a hazardous area. Intrinsically safe barriers, as Zener, are installed in the circuit to limit current and voltage in the hazardous areas to avoid sparks or hot spots under fault conditions.

The assembly must be installed strictly in accordance with the installation instruction supplied by the manufacturer.

Think Top Basic Intrinsically Safe is suitable for use in hazardous area zone 1 and zone 21

Marking: Ex II 2D/G EEx ia IIC T6

The Notified Body NB.0044 will retain this Declaration of Conformity TÜV-Nord technical file no.: TÜV 08 ATEX 8000365231

The person authorised to compile the technical file is the signer of this document

Global Product Quality Manager
Pump, Valves, Fittings and Tank Equipment

Title

Lars Kruse Andersen

Name

Kolding

Place

2016-05-01

Date



Signature



*This manual highlights unsafe practices and other important information.
Warnings are emphasised by means of special signs. All warnings in the manual are summarised on this page.
Pay special attention to the instructions below in order to avoid severe personal injury or damage to the top unit.*

2.1 Important information

Always read the manual before using the top unit!

WARNING

Indicates that special procedures must be followed to avoid serious personal injury.

CAUTION

Indicates that special procedures must be followed to avoid damage to the ThinkTop.

NOTE

Indicates important information to simplify or clarify procedures.

2.2 Warning signs

General warning:



Caustic agents:



2.3 Safety precautions

Installation:

Always read the technical data thoroughly

Never install the ThinkTop before the valve or relay are in a safe position

If welding close to the ThinkTop: **Always** perform earthing close to the welding area

Disconnect the ThinkTop



Always ensure the ThinkTop is electrically connected by authorised personnel



The ThinkTop must be installed in an inherently safe circuit, according to the corresponding regulations.

Maintenance:

Always read the technical data carefully.

Always fit the seals between the valve and ThinkTop correctly

Never install the ThinkTop before the valve or relay are in a safe position

Never service the ThinkTop with the valve/actuator under pressure

Never clean the ThinkTop with high pressure cleaning equipment

Never use cleaning agents when cleaning the ThinkTop. Check with cleaning agent supplier.



3 General information

*This manual highlights unsafe practices and other important information.
Warnings are emphasised by means of special signs. All warnings in the manual are summarised on this page.
Pay special attention to the instructions below in order to avoid severe personal injury or damage to the top unit.*

3.1 ThinkTop Basic Intrinsically Safe at a glance

The ThinkTop Basic Intrinsically Safe is designed to ensure optimum valve control in conjunction with Alfa Laval valves.

The ThinkTop Basic Intrinsically Safe can be equipped with 0-2 solenoid valves. The solenoids are electrically controlled by the Digital PLC and, when activated, the compressed air is activating the air actuator. The solenoids are also equipped with a manual hold override.

The ThinkTop Basic Intrinsically Safe does not support Unique SSV Long Stroke and SRC-LS valves.

Important!

The end user is responsible for performing the explosion risk assessment and classifying the group and the corresponding zone (dust or gas) in accordance with the Directive 1999/92/EC.

The following table shows the ATEX evaluated Alfa Laval sanitary valves as ThinkTop Basic Intrinsically Safe can be installed on and in accordance with ATEX Directive 94/9/EC.

Valve / actuator type	ATEX evaluation notes
Unique SSV ATEX	 II 2 G D c T4
Unique Mixproof	Non-electric equipment with no own ignition source which can be used within equipment group II 2 G/D or II 3 G/D if removing the blue plastic cover on bottom of Mixproof valve
SRC SMP-SC SMP-TO SMP-BC LKLA-T Koltek MH SBV	Non-electric equipment with no own ignition source which can be used within equipment-group II 2 G/D or II 3 G/D

Note! Contact customer support to obtain the "ATEX Product Statement 2009" with listed valves inside/outside the scope of ATEX Directive 94/9/EC

3.2 Recycling information

• Unpacking

- Packing material consists of wood, plastics and cardboard boxes
- Wood and cardboard boxes can be reused, recycled or used for energy recovery
- Plastics should be recycled or incinerated at a licensed waste incineration plant

• Maintenance

- All metal parts should be sent for material recycling
- Worn or defective electronic parts should be sent to a licensed handler for material recycling
- All non-metal wear parts must be handled in accordance with local regulations

• Scrapping

- End-of-life equipment shall be recycled according to relevant, local regulations. In addition to the equipment itself, any hazardous residue from the process liquid must be taken into account and handled in the necessary way. When in doubt, or in the absence of local regulations, please contact the local Alfa Laval sales company

4 Technical specifications

This manual highlights unsafe practices and other important information.

Warnings are emphasised by means of special signs. All warnings in the manual are summarised on this page.

Pay special attention to the instructions below in order to avoid severe personal injury or damage to the top unit.

Solenoid valves	
0 to 2 solenoid valves in each unit possible.	
Type	3/2 port
Air supply	0.15 - 0.7 MPa (1.5-7 bar)
Filtered air, max. particles or dirt	5 µ 5-5 mg/m ³
Max. flow	180 l/min
Max. oil content	1 mg/m ³
Max. water content	0.88 g/m ³ -20 °C compressed air
Throughput	ø2.5 mm
Air restriction (throttle function)	No
Manual hold override	Yes
External air tube connection	ø6 mm or 1/4". (specify when ordering)
Silencer/filter	Connection possible via ø6 mm (Filter recommended in tropical regions)
Nominal voltage	12 VDC
Nominal power	0.52 W
Allowable voltage fluctuation	±10% of rated voltage
Certificate of conformity	KEMA 08 ATEX 0093 X
Inductive sensor	
Switching element function	NAMUR NC
Nominal voltage: U _o	8 V
Measuring plate not detected	3 mA
Measuring plate detected	1 mA
Indication of switching state:	LED, yellow
EMC in accordance with	IEC / EN 60947-5-2:2004; NE 21
Standards	DIN EN 60947-5-6 (NAMUR)
Certificate of conformity	PTB 00 ATEX 2032 X
Materials	
Plastic parts	Nylon PA6, reinforced, stainless steel fibres
Metal parts	Stainless steel and bras
Seals	Nitrile (NBR)
Gore vent. membrane	PBT plastic

Micro environment demand specifications

Temperature		
Working:	-10°C to +45°C	EN 50020
Storage:	-40°C to +85°C	IEC 68-2-1/2
Temperature change:	-25°C to +70°C	IEC 68-2-14
Vibration		
	10-55 Hz, 0.7 mm	IEC 68-2-6
	55-500 Hz, 10g	
	3 x 30 min, 1 octave/min	
Drop test		
		IEC 68-2-32
Humidity		
Constant humidity:	+40°C, 21 days, 93% R.H.	IEC 60068-2-78
Cyclic humidity:	+15°C/+45°C	EN 60068-2-30
	12 cycles	
(working)	93% R.H.	
Protection class		
	IP66 and IP67	EN 60529
Surface resistance		
	< 1G Ω (ohm)	EN 60079-0
Type of ex protection		
	Ex II 2G/D EEx ia IIC T6	ATEX directive 94/9/EC

5 Installation

This manual highlights unsafe practices and other important information. Warnings are emphasised by means of special signs. All warnings in the manual are summarised on this page. Pay special attention to the instructions below in order to avoid severe personal injury or damage to the top unit.

5.1 Installation on air actuators

Step 1



Always read the technical data carefully.



Always ensure the ThinkTop is electrically connected by authorised personnel.

Step 2

1. Fit the air fittings on actuator if not mounted.
2. Fit the activator on the stem and tighten **carefully** with a spanner.

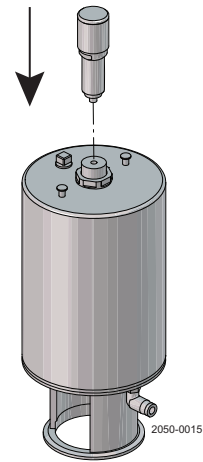

Step 3

1. Place the ThinkTop Basic Intrinsically Safe on top of the actuator.
2. Make sure X-ring is mounted.

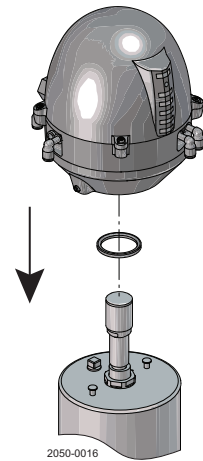

This manual highlights unsafe practices and other important information. Warnings are emphasised by means of special signs. All warnings in the manual are summarised on this page. Pay special attention to the instructions below in order to avoid severe personal injury or damage to the top unit.

Step 4

1. Ensure that the unit is correctly mounted by **pressing** down on top of the ThinkTop Basic Intrinsicly Safe.
2. Cross-tighten the two Allen screws **carefully** in the two opposite directions.
3. Turn the actuator so that LEDs are at front

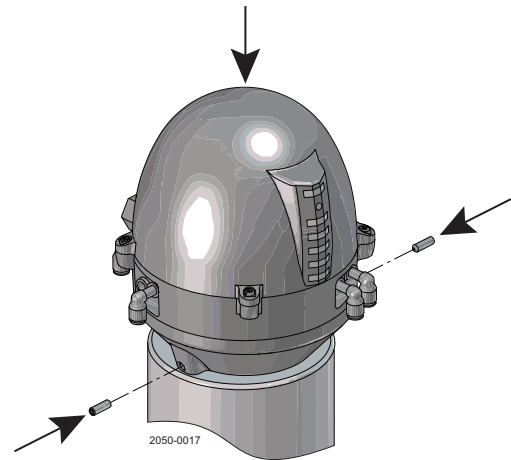

Step 5

Install the air tubes with reference to the Air connections diagram on page 10.

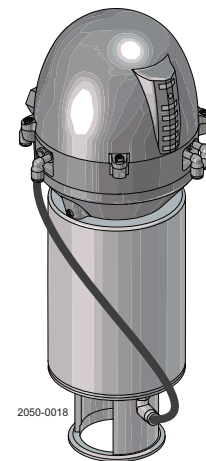

Step 6

Untighten the four screws and pull off the cover of ThinkTop Basic Intrinsicly Safe.

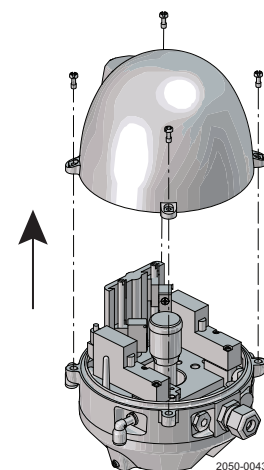

5 Installation

This manual highlights unsafe practices and other important information.

Warnings are emphasised by means of special signs. All warnings in the manual are summarised on this page.

Pay special attention to the instructions below in order to avoid severe personal injury or damage to the top unit.

Step 7

1. Install cable (if not present) through the cable gland.
2. Connect the electrics of the ThinkTop Basic Intrinsicly Safe (see page11 "Electrical connection, internal").

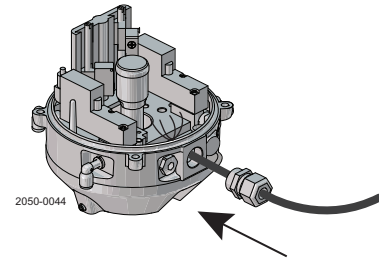

Step 8

Make sure the cable gland is fully tightened.

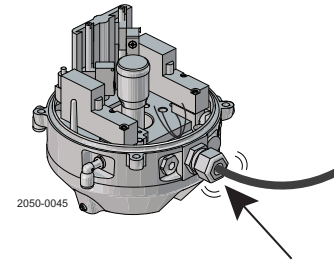

Step 9

Positioning of the inductive proximity switches

1. The two screws (26) holding the sensor frame shall be tightened slightly to enable the frame to be moved back and forth.
2. Align the marking on the left proximity switch with the indication pin by turning the left set screw.
3. Energise the valve
4. Align the right proximity switch with the indication pin by turning the right set screw
5. The proximity switches must be close to the indication pin, but not touch. Shear the frame for correction
6. Tighten the two screws holding the sensor frame (1 Nm)

NOTE!

To energise the valve, use the Manual hold override on the Solenoid valve.

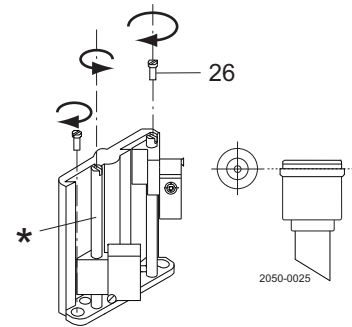

5.2 Air connections

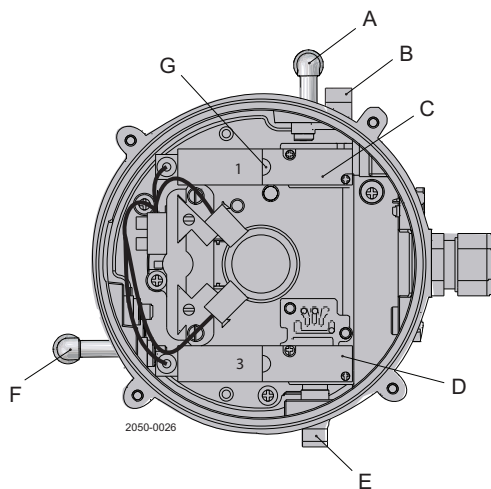

- A. Air out 1A
- B. Air exhaust
- C. Solenoid 3/2
- D. Solenoid 3/2
- E. Air in
- F. Air out 3
- G. Manual hold override

This manual highlights unsafe practices and other important information. Warnings are emphasised by means of special signs. All warnings in the manual are summarised on this page. Pay special attention to the instructions below in order to avoid severe personal injury or damage to the top unit.

5.3 Electrical connection, internal

Electrical connection

The ThinkTop Basic Intrinsically Safe must always be installed in an intrinsically safe circuit.

Sensor

The two inductive NAMUR sensors must be connected to a certified intrinsically safe circuit (e.g. Zener barrier) for apparatus group IIC with the following maximum values:

$U_i = 15V$
 $I_i = 50mA$
 $P_i = 1W$
 $L_i = 100\mu H$
 $C_i = 100nF$

Solenoid valve

The intrinsic safe solenoid valves must also be connected to a certified intrinsically safe circuit (e.g. Zener barrier) for apparatus group IIC with the following maximum values:

$U_i = 28V$
 $I_i = 225mA$
 $P_i = 1W$
 $L_i = 0mH$
 $C_i = 0nF$

The electrical installation of ThinkTop Basic Intrinsically Safe must be done according to standard EN 60079-14.

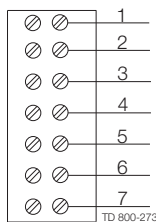
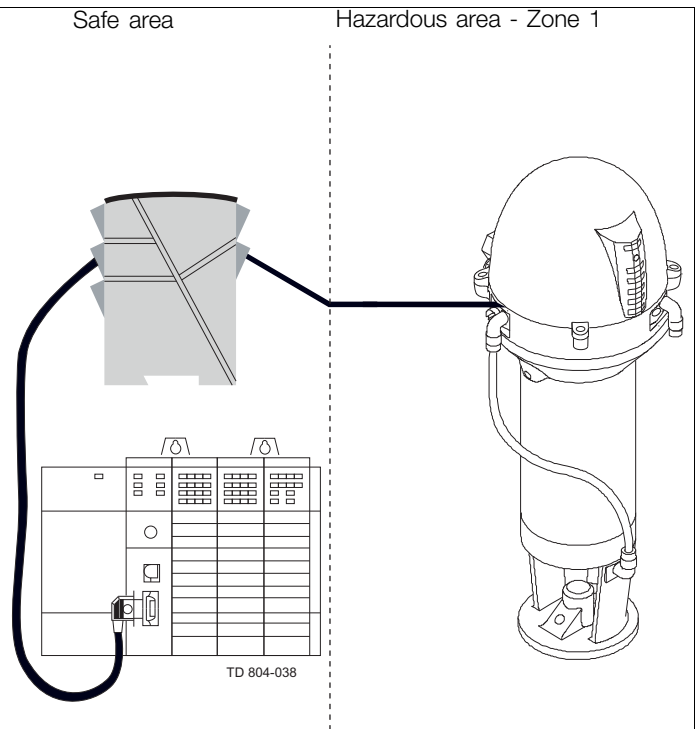

Electrical connections, internal

1. Sensor 1 [de-energised] (blue) 8 VDC (-)
2. Sensor 1 [de-energised] (brown) (+)
3. Sensor 2 [energised] (blue) 8 VDC (-)
4. Sensor 2 [energised] (brown) (+)
5. Common; solenoids (black) 12 VDC (-)
6. Input; solenoid #1 (red) (+)
7. Input; solenoid #3 (red) (+)

6 Maintenance

Read the instructions carefully.

Handle scrap correctly.

Always have spare X-rings in to hand.

6.1 Dismantling of ThinkTop Basic Intrinsically Safe

Step 1

1. Untighten the two Allen screws and remove the ThinkTop from the actuator
2. Remove X-ring and replace it

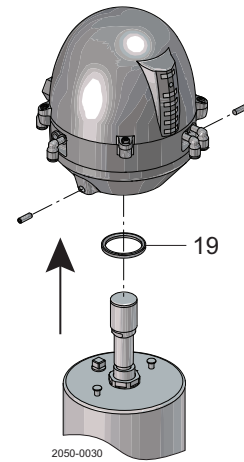

Step 2

1. Untighten the four screws
2. Remove cover of ThinkTop
3. Remove X-ring (grey)

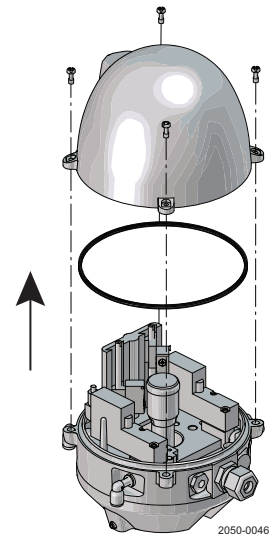

Step 3

1. Untighten screws
2. Remove solenoid valves (up to two) and replace them with new ones

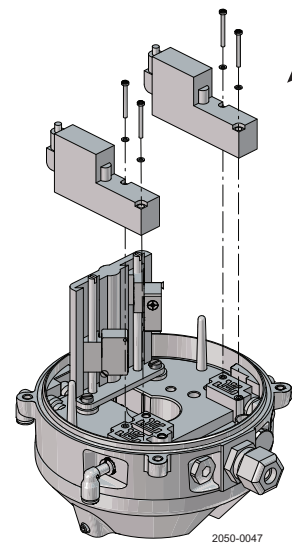

*Read the instructions carefully.
Handle scrap correctly.
Always have spare X-rings in to hand.*

Step 4

1. To dismantle the adapter (the lower part of the ThinkTop bracket from base (the middle part), unscrew the three screws
2. Turn the lower part clockwise slightly and pull
3. Replace adapter if necessary
4. Remove the black X-ring

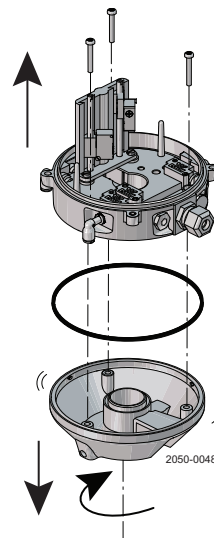

Note:
Turn banjo connection!

Step 5

To remove the sensor frame, unscrew the three screws and pull out the frame.

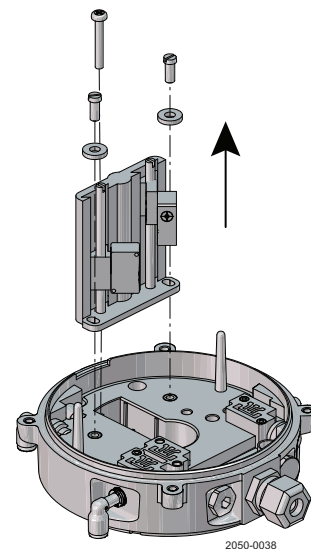

6 Maintenance

Read the instructions carefully.

Handle scrap correctly.

Always have spare X-rings in to hand.

6.2 Assembly of ThinkTop Basic Intrinsically Safe

Step 1

Place sensor frame in base on top of the four washers, two under each side, and tighten screws (torque: 1 Nm).

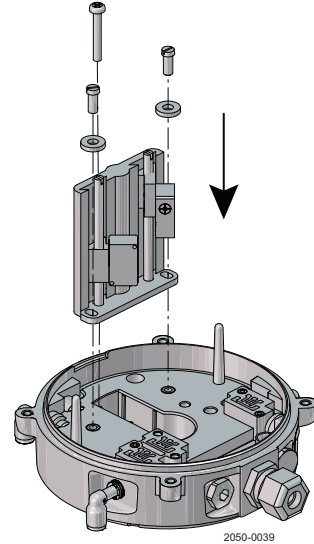

Step 2

1. Replace the black X-ring.
2. Assemble base with adapter by turning adapter slightly anticlockwise and tighten the four screws (2 Nm).

CAUTION!

Do NOT twist the X-ring in the groove!

The X-ring is not square.

The highest (h) part must be positioned as shown

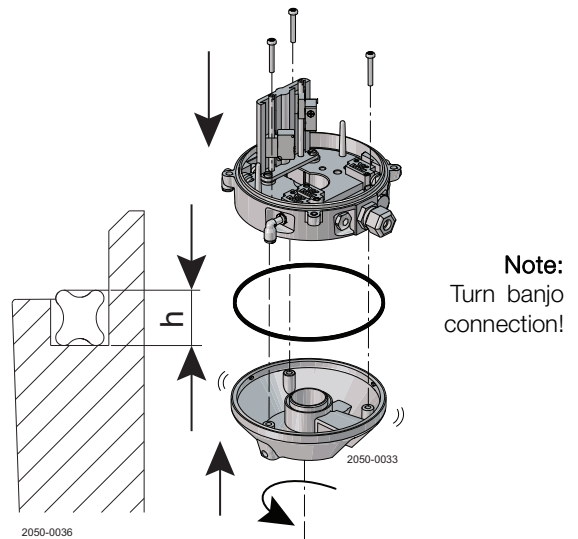

Step 3

1. Replace solenoid valves (up to two) with new ones.
2. Tighten screws (0.2 Nm).

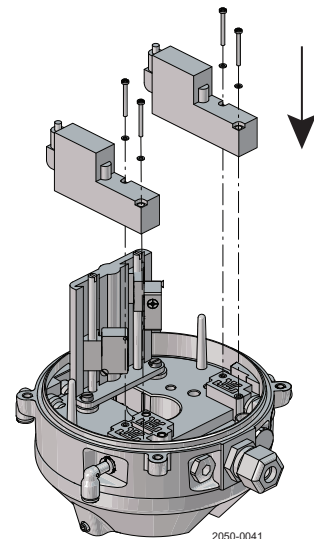

Read the instructions carefully.

Handle scrap correctly.

Always have spare X-rings in to hand.

Step 4

1. Replace the grey X-ring.
2. Replace cover of ThinkTop Basic Intrinsically Safe and tighten the four screws (0.6 Nm).

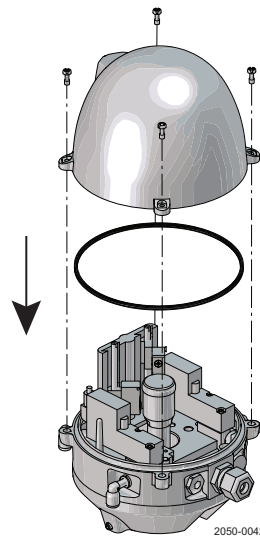

Step 5

1. Replace the black X-ring.
2. Mount ThinkTop Basic Intrinsically Safe on actuator.

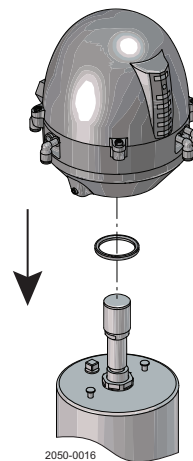

7 Parts list and service kits

The diagrams illustrate ThinkTop Basic Intrinsically Safe.
The items refer to the parts lists in the following sections

7.1 Diagrams for ThinkTop Basic Intrinsically Safe

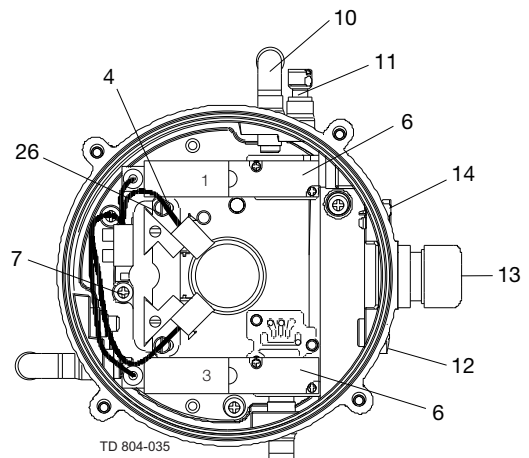
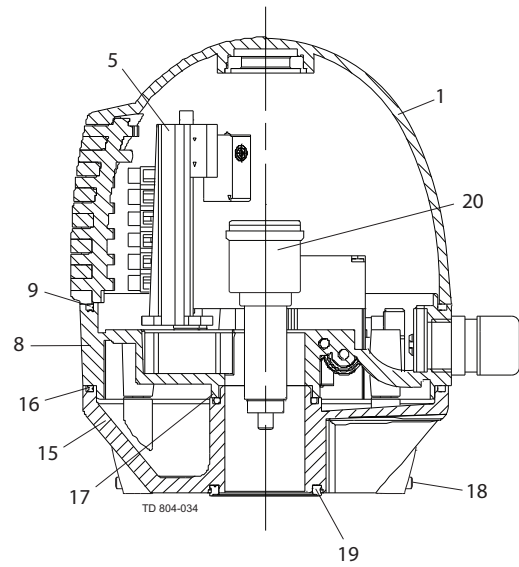
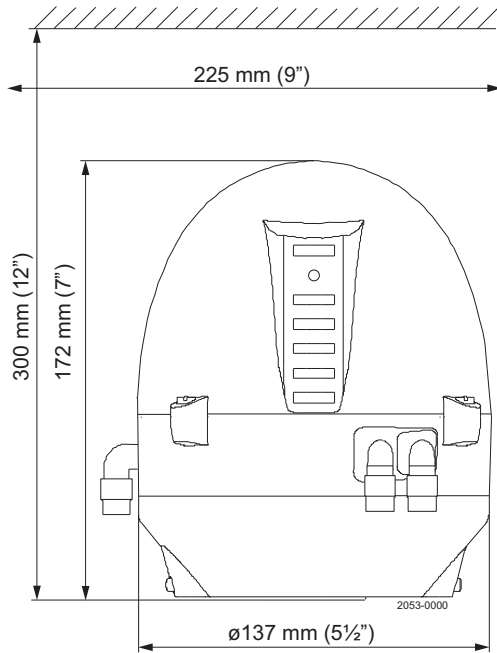

7 Parts list and service kits

The diagrams illustrate ThinkTop Basic Intrinsically Safe.
The items refer to the parts lists in the following sections

7.2 ThinkTop Basic Intrinsically Safe

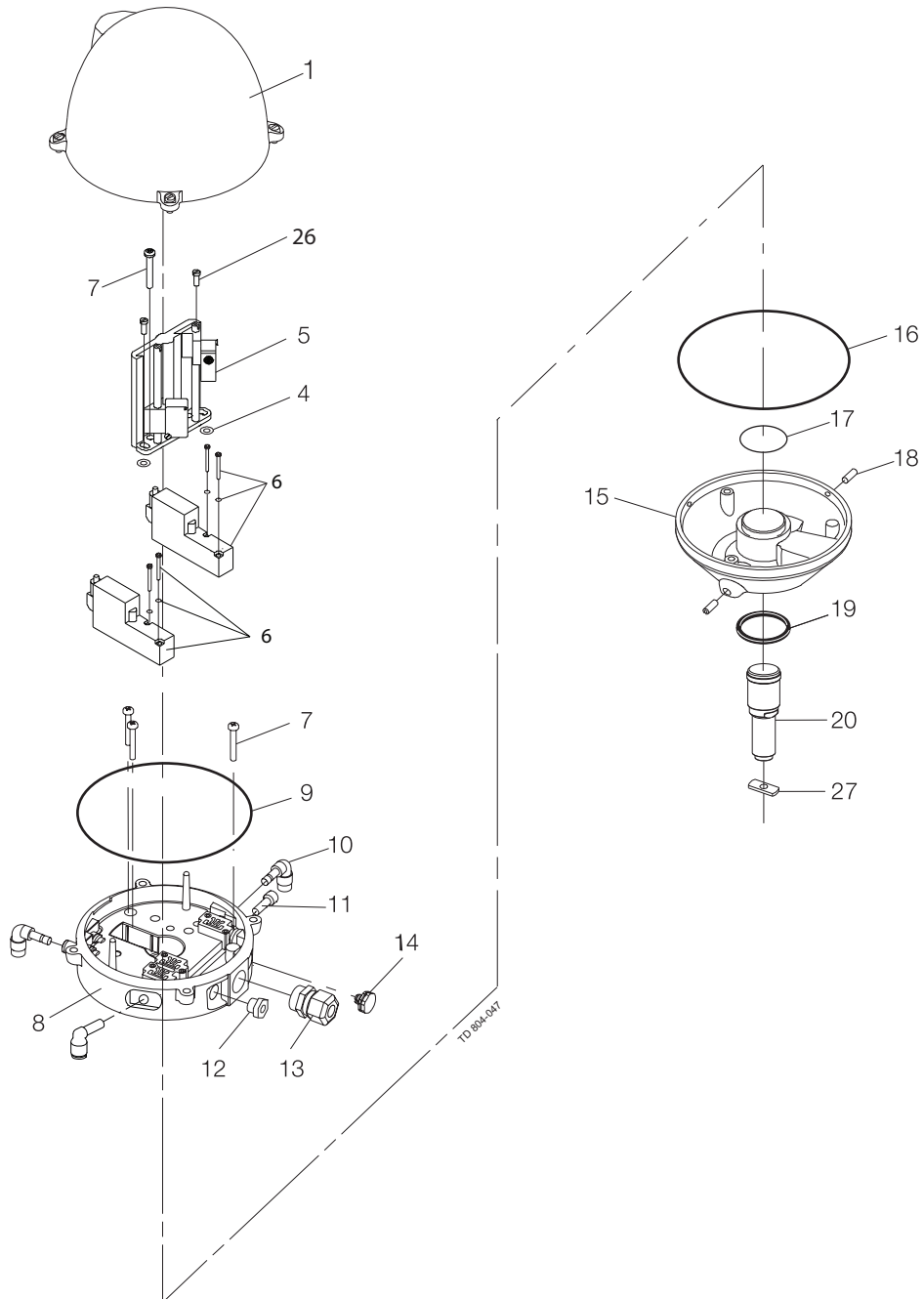

7 Parts list and service kits

*The diagrams illustrate ThinkTop Basic Intrinsically Safe.
The items refer to the parts lists in the following sections*

Parts list

Pos.	Qty	Denomination
1	1	Shell, complete
4	2	Washer
5	1	Frame cpl. with sensors
6	1-2	Solenoid valve (3/2)
7	4	PT screw
8	1	Base
9	1	Special X-ring, grey
10	2-3	Air fitting elbow
11	1	Blow-off valve
12	1	Thread plug, PG7
13	1	Cable gland, PG11
14	1	Gore vent
15	1	Adapter complete
16	1	Special X-ring, black
17	1	O-ring
18	2	Allen screw
19	1	Special X-ring
20	1	Indication pin
26	2	Screw
27	1	Threaded plate (accessories for the Think Top)

How to contact Alfa Laval

Contact details for all countries are continually updated on our website.

Please visit www.alfalaval.com to access the information directly.

© Alfa Laval Corporate AB

This document and its contents is owned by Alfa Laval Corporate AB and protected by laws governing intellectual property and thereto related rights. It is the responsibility of the user of this document to comply with all applicable intellectual property laws. Without limiting any rights related to this document, no part of this document may be copied, reproduced or transmitted in any form or by any means (electronic, mechanical, photocopying, recording, or otherwise), or for any purpose, without the expressed permission of Alfa Laval Corporate AB. Alfa Laval Corporate AB will enforce its rights related to this document to the fullest extent of the law, including the seeking of criminal prosecution.