

Field of Application

Fitting to be built into pipe conduits to allow the inspection of liquids.



ATTENTION

To avoid danger and damage, the fitting must be used in accordance with the safety instructions and technical data contained in the operating instructions.

Welding Guidelines



DANGER

If the maximum permissible working pressure is exceeded, accident hazard due to bursting of the glass cylinder or discharge of liquids into the atmosphere is possible. In order to avoid excess pressure install overpressure protections. The fitting position has to be chosen in such a way as to exclude danger of accident. In order to prevent accident hazards, provide appropriate protective devices.

Installation instructions

The installation position is without import. External forces due to the installation must always be avoided.

Disassembly and assembly

Disassembly

- Determine size "A" (see fig. 1).
- Unscrew hexagonal nut (7) on *one* side.
- Remove flange (1) seal (6)(2x) and glass cylinder (3) axially.
- Position flange (1) on the thread bolt (4) to the end stop of the hexagonal nut (5) and tighten with hexagonal nut (7).
- Check determined size "A". If required, adjust via the hexagonal nut (5).

Make sure the flanges are planar parallel.

Assembly

- Install seal (6) (2x) and glass cylinder (3) at centre.
- Position flange (1) with detachable connection on the thread bolt (4) to the end stop of the hexagonal nut (5) and tighten with hexagonal nut (7).

Dimensions

DN	L1	L2	L3	L4	A	D1	D2	D3	hole circle LK
10	65	135	33	37	~ 61	Ø 13x1,5	Ø 44	Rd 28x1/8	Ø 32
15	65	135	33	37	~ 61	Ø 19x1,5	Ø 49	Rd 34x1/8	Ø 37
20	75	149	34	40	~ 71	Ø 23x1,5	Ø 54	Rd 44x1/8	Ø 43
25	75	149	43	31	~ 69	Ø 29x1,5	Ø 80	Rd 52x1/8	Ø 65
32	75	152	46	31	~ 69	Ø 35x1,5	Ø 86	Rd 58x1/8	Ø 71
40	85	163	47	31	~ 79	Ø 41x1,5	Ø 92	Rd 65x1/8	Ø 77
50	85	169	51	33	~ 79	Ø 53x1,5	Ø 108	Rd 78x1/8	Ø 92
65	85	170	53	32	~ 77	Ø 70x2	Ø 130	Rd 95x1/8	Ø 110
80	85	189	51	29	~ 77	Ø 85x2	Ø 146	Rd 110x1/8	Ø 126
100	100	209	40	40	~ 92	Ø 104x2	Ø 166	Rd 130x1/8	Ø 146

Measures in mm

Tab.1

- Make sure the flanges are planar parallel.
- Tighten detachable connection provided
- Check fitting for leaks.
- If the fitting leaks, loosen the hexagonal nut (5) and evenly retighten the hexagonal nut (7).
- Make sure the flanges are planar parallel.
- Tighten hexagonal nut (5).

Technical data

- Design:** sight glass - protecting cage
Valve size: DN 10 -100
Connection: Liner/nut - male part
Temperature: max. 90°C depending on medium
Operating pressure: max. 6 bar = DN100
max. 8 bar = DN40; DN80
max. 10 bar = DN10-25; DN50; DN65

Material:	in product contact	not in product contact
Stainless steel:	1.4301 / ASI304 1.4404 / AISI316L	1.4301 / ASI304
Surfaces:	RA 0,8µm	RA 1,5 - 2,5µm E-polish
Seals:	NBR	-
Glass cylinder:	Borosilicate	

☐ Spare parts list

Article-No.	Pos. 1 Flange liner/nut <i>AISI 304 / 316L</i>	Pos. 2 Protecting cage <i>AISI 304</i>	Pos. 3 Glass cylinder <i>Borosilicate</i>	Pos. 4 Thread bolt <i>AISI 304</i>	Pos. 5 Hex. nut DIN934 <i>AISI 304</i>	Pos. 6 Seal <i>NBR</i>	Pos. 7 Hex. nut DIN985 <i>AISI 304</i>	Pos.8 Flange male part <i>AISI 304 / 316L</i>
7008 010 130-021	7008 010 001-021	7011 010 000-021	7012 010 000-073	7006 015 002-020 <i>M6x96 (3x)</i>	8107 006 000-020 <i>M6 (6x)</i>	2354 020 010-067 <i>(2x)</i>	8115 006 000-020 <i>M6 (6x)</i>	7007 010 001-020
7008 010 130-041	7008 010 001-041							7007 010 001-040
7008 015 130-021	7008 015 001-021	7011 015 000-021	7012 015 000-073	7006 015 002-020 <i>M6x96 (3x)</i>	8107 006 000-020 <i>M6 (6x)</i>	2354 025 016-067 <i>(2x)</i>	8115 006 000-020 <i>M6 (6x)</i>	7007 015 001-020
7008 015 130-041	7008 015 001-041							7007 015 001-040
7008 020 130-021	7008 020 001-021	7011 020 000-021	7012 020 000-073	7006 020 002-020 <i>M6x106 (3x)</i>	8107 006 000-020 <i>M6 (6x)</i>	2354 031 020-067 <i>(2x)</i>	8115 006 000-020 <i>M6 (6x)</i>	7007 020 001-020
7008 020 130-041	7008 020 001-041							7007 020 001-040
7008 025 130-021	7008 025 001-021	7011 025 000-021	7012 025 000-073	7006 032 002-020 <i>M8x105 (4x)</i>	8107 008 000-020 <i>M8 (8x)</i>	2355 036 026-067 <i>(2x)</i>	8115 008 000-020 <i>M8 (8x)</i>	7007 025 001-020
7008 025 130-041	7008 025 001-041							7007 025 001-040
7008 032 130-021	7008 032 001-021	7011 032 000-021	7012 032 000-073	7006 032 002-020 <i>M8x105 (4x)</i>	8107 008 000-020 <i>M8 (8x)</i>	2355 042 032-067 <i>(2x)</i>	8115 008 000-020 <i>M8 (8x)</i>	7007 032 001-020
7008 032 130-041	7008 032 001-041							7007 032 001-040
7008 040 130-021	7008 040 001-021	7011 040 000-021	7012 040 000-073	7006 065 002-020 <i>M8x115 (4x)</i>	8107 008 000-020 <i>M8 (8x)</i>	2355 052 038-067 <i>(2x)</i>	8115 008 000-020 <i>M8 (8x)</i>	7007 040 001-020
7008 040 130-041	7008 040 001-041							7007 040 001-040
7008 050 130-021	7008 050 001-021	7011 050 000-021	7012 050 000-073	7006 065 002-020 <i>M8x115 (4x)</i>	8107 008 000-020 <i>M8 (8x)</i>	2355 064 050-067 <i>(2x)</i>	8115 008 000-020 <i>M8 (8x)</i>	7007 050 001-020
7008 050 130-041	7008 050 001-041							7007 050 001-040
7008 065 130-021	7008 065 001-021	7011 065 000-021	7012 065 000-073	7006 065 002-020 <i>M8x115 (4x)</i>	8107 008 000-020 <i>M8 (8x)</i>	2355 079 066-067 <i>(2x)</i>	8115 008 000-020 <i>M8 (8x)</i>	7007 065 001-020
7008 065 130-041	7008 065 001-041							7007 065 001-040
7008 080 130-021	7008 080 001-021	7011 080 000-021	7012 080 000-073	7006 080 002-020 <i>M10x123(4x)</i>	8107 010 000-020 <i>M10 (8x)</i>	2355 094 081-067 <i>(2x)</i>	8115 010 000-020 <i>M10 (8x)</i>	7007 080 001-020
7008 080 130-041	7008 080 001-041							7007 080 001-040
7008 100 130-021	7006 100 001-020	7011 100 000-021	7012 100 000-073	7006 100 002-020 <i>M10x138(4x)</i>	8107 010 000-020 <i>M10 (8x)</i>	2355 114 100-067 <i>(2x)</i>	8115 010 000-020 <i>M10 (8x)</i>	7006 100 001-020
7008 100 130-041	7006 100 001-040							7006 100 001-040

Tab.2

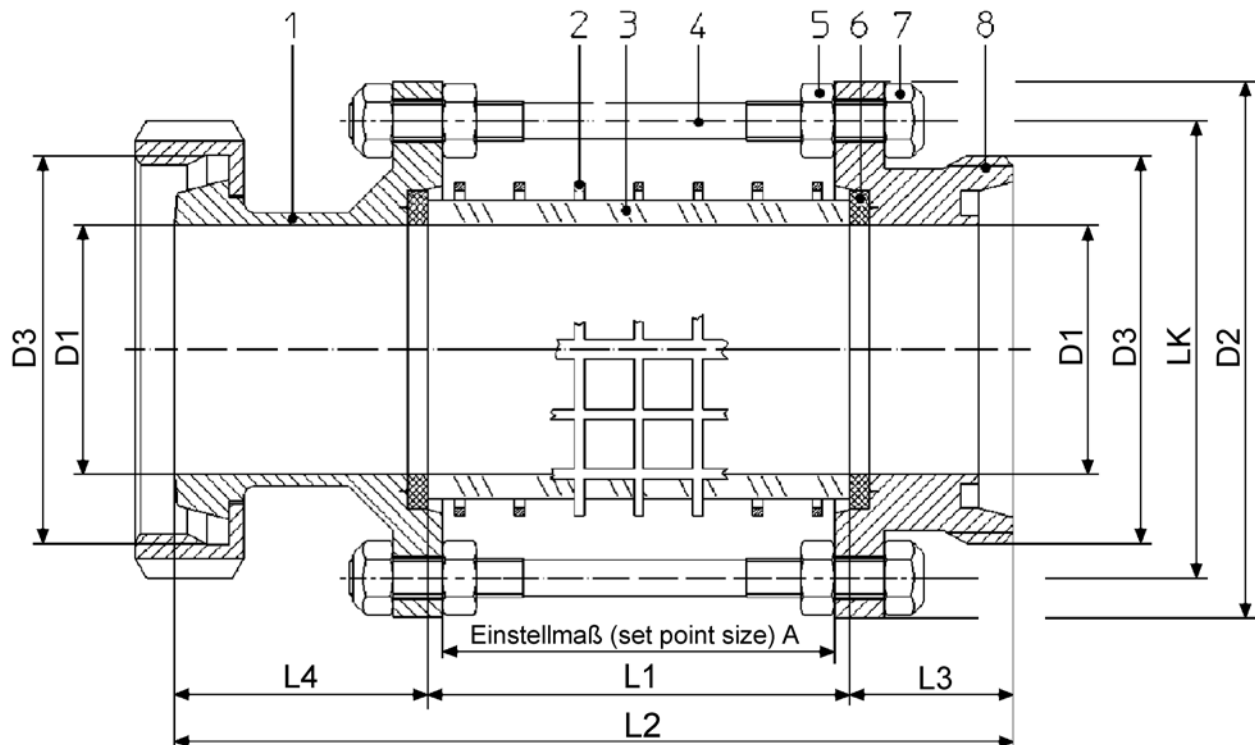

Fig. 1