



INSTALLATION, SERVICE AND MAINTENANCE INSTRUCTIONS

BALL VALVE



INOXPA, S.A.
c/Telers, 54 Apto. 174
E-17820 Banyoles
Girona (Spain)
Tel. : (34) 972 - 57 52 00
Fax. : (34) 972 - 57 55 02
Email: inoxpa@inoxpa.com
www.inoxpa.com



Original Manual
10.100.30.00EN_RevD
ED. 2012/10



EC DECLARATION OF CONFORMITY

(according to Directive 2006/42/CE, annex II, part A)

Manufacturer: INOXPA, S.A.
C/ Telers, 54
17820 Banyoles (Girona) - SPAIN

Hereby declares, that the product:

VALVE

BALL

Name

Type

conforms to the specifications of the Council Directive:

Machine Directive 98/37/CE, and complies with the essential requirements of the Directive and Harmonised Standards:

UNE-EN ISO 12100-1/2:2004
UNE-EN 953:1997
UNE-EN ISO 13732-1:2007

Pressure Equipment Directive 97/23/CE, the equipment has been designed and manufactured in accordance with the requirements of the Directive.

Max operating P.: DN-25/1" to DN-65/2 1/2" = 10 bar; DN-80/3" to DN-100/4" = 8 bar

Diameter: DN-25

Equipment category: SEP = Sound Engineering Practice, determined according to Article 3 Section 1.3.a, first paragraph Annex II, Table 6

This material SHALL NOT carry CE marking.

Diameter: DN-25 < X < ó = DN-100

Equipment category: Category I, determined according Article 3 Section 1.3.a, first paragraph Annex II, Table 6

This material SHALL carry CE marking.

Conformity Assessment Module: Module A

In compliance with the Regulations (CE) n° 1935/2004, relating to materials and articles intended to come into contact with foodstuff (repeal Directive 89/109/CEE), the materials in contact with the product do not transfer their components in quantities which may jeopardise consumer's health or safety.

Declaration of Incorporation (Directive 2006/42/CE, annex II, part B):

The equipments above mentioned won't put to operation till the machine into or onto it will be installed must comply with the stipulations of the Machine Directive.

Banyoles, 2012

Marc Pons Bague Technical Manager

1. Safety

1.1. INSTRUCTION MANUAL.

This instruction manual contains basic indications which should be fulfilled during the installation, starting and maintenance. The information published in the instruction manual is based on updated information. INOXPA reserves the right to modify this instruction manual without prior notice.

1.2. INSTRUCTIONS FOR START-UP.

This instruction manual contains vital and useful information to appropriately handle and maintain your valve. Not only should the safety instructions indicated in this chapter be observed and fulfilled, but so should the special measures and recommendations included in the other chapters of this manual. These instructions should be kept in a safe location near the installation.

1.3. SAFETY.

1.3.1. Warning symbols.



Danger for persons in general



Danger of injury caused by rotating equipment parts.



Electric danger



Danger! Caustic or corrosive agents.



Danger! Suspended loads



Danger for the correct operation of the equipment.



Commitment to safety at the workplace.



Protective goggles requirement.

1.4. GENERAL SAFETY INSTRUCTIONS.



Read the instruction manual carefully before installing and starting up the valve. Contact INOXPA in case of doubt.

1.4.1. During the installation.



The *Technical Specifications* of Chapter 8 should always be observed.

The installation and use of the valve/actuator should always be carried out in accordance with applicable regulations regarding health and safety.

Before starting up the valve/actuator, verify that the assembly is correct and that the shaft is perfectly aligned. An incorrect alignment and/or excessive force in securing the valve/actuator may cause serious mechanical problems in the valve/actuator.



During the installation, all the electric work should be carried out by authorised personnel.

1.4.2. During operation.



The *Technical Specifications* of Chapter 8 should always be observed. Under no circumstances can the limit values specified be exceeded.



NEVER touch the valve and/or pipes in contact with the liquid during operation; there is a risk of burns if it operates with hot products.

Do not operate the handlever in case of failure; the springs are not protected.



The valve/actuator contains rotating parts. Do not place the fingers or hands in the coupling between the valve and the actuator when the compressed air is connected; this may cause serious injuries.

1.4.3. During maintenance



The *Technical Specifications* of Chapter 8 should always be observed.

NEVER disassemble the valve until the pipes have been emptied. Bear in mind that the liquid in the pipe may be dangerous or extremely hot. Consult the regulations in effect in each country for these cases.

Do not leave parts loose on the floor.



All the electric work should be carried out by authorised personnel.

1.4.4. In compliance with the instructions.

Any nonfulfillment of the instructions may result in a risk for the operators, the environment and the machine, and may result in the loss of rights to make claims.

This nonfulfillment may result in the following risks:

- Failure of important functions of the machines/plant.
- Failure in specific maintenance and repair procedures.
- Possibility of electric, mechanical and chemical risks.
- Will place the environment in danger due to the release of substances.

1.5. GUARANTEE.

Any guarantee will be cancelled immediately and as a matter of law and, in addition, we will require compensation for any claims of civil liability presented by third parties, in case:

- The installation and maintenance work has not been carried out according to the instructions of this manual.
- The repairs are not carried out by our personnel or have been carried out without our written authorisation.
- The parts used are not INOXPA genuine parts.
- Modifications have been carried out on our materials without written authorisation.
- The material has been badly used, incorrectly used, or used with negligence or has not been used according to the indications and intended use specified in this manual.

The general conditions of delivery already in your possession are also applicable.

Please do not hesitate to contact us in case of doubts or more complete explanations are required on specific data (adjustments, assembly, disassembly, etc.).

2. Table of Contents

1. Safety	
1.1. Instruction manual	3
1.2. Instructions for start-up.....	3
1.3. Safety.	3
1.4. General safety instructions.....	3
1.5. Guarantee.	4
2. Table of contents	
3. Receiving and installation	
3.1. Check shipment	6
3.2. Delivery and unpacking	6
3.3. Identification	6
3.4. Location.	7
3.5. Assembly.....	7
3.6. Checking and inspection.	7
3.7. Welding	7
3.8. Air connection to actuator.....	9
4. Start-up	
4.1. Start-up.....	10
4.2. Operation.	10
5. Troubleshooting	
6. Maintenance	
6.1. General information.....	12
6.2. Maintenance.	12
6.3. Cleaning	13
7. Assembly and disassembly	
7.1. Disassembly / Assembly of valve with two-position handlever.	15
7.2. Disassembly / Assembly of valve with VERTICAL pneumatic actuator	16
7.3. Seal assembly.	17
7.4. Actuator assembly options.....	17
7.5. Valve position.	17
8. Technical specifications	
8.1. Technical specifications	18
8.2. Manual valve dimensions	20
8.3. Dimensions with VERTICAL pneumatic operation	20
8.4. Section and parts list.....	23
8.5. Parts lists.....	23

3. Receiving and installation

3.1. CHECK THE SHIPMENT

The first thing to do on receiving the valve is to verify that it is in accordance with the delivery slip. INOXPA will inspect all the equipment before packing, although it cannot guarantee that the merchandise will arrive intact to the user. For this reason, the valve received and any other article should be checked and, in case it is found not to be in good condition and/or not all parts are included, the carrier should submit a report as soon as possible.

Each valve has a manufacturing number engraved. Indicate the manufacturing number in all documents and correspondence. In case that the valve is supplied with actuator, this will have a label with the following information:



VALVULAS NEUMATICAS / AIR OPERATED VALVES

Nº FIGURA: <i>FIGURE NR:</i>	TAMAÑO: <i>SIZE:</i>
TIPO ACTUADOR: <i>ACTUATOR TYPE:</i>	
PRESION DE TRABAJO: min <i>WORKING PRESSURE: min</i>	/máx <i>/max</i>
Nº FABRICACION: <i>MANUFACTURING NR.:</i>	MODELO: <i>MODEL:</i>

Serial number →

3.2. DELIVERY AND UNPACKING



INOXPA will not be responsible for the inappropriate unpacking of the valve, actuator and its components.

3.2.1. Delivery:

Check that all the parts indicated in the delivery slip exist

- Complete valve.
- Actuator and its components (in case supplied).
- Delivery slip.
- Instruction manual.

3.2.2. Unpacking:

- Remove all traces of packing materials from the valve or parts. Valves with manual or pneumatic operation and components will be delivered assembled.
- Inspect the valve or the parts of which it is formed for possible damage incurred during transport.
- Avoid any possible damage to the valve/actuator and its components.

3.3. IDENTIFICATION

2	64	00	050	S	B						
					MANETA B - 2 posiciones D - Con detector pos.						
					MATERIAL JUNTAS E - EPDM S - Silicona						
					DIÁMETRO NOMINAL DEN <table border="1" style="margin-left: auto; margin-right: auto;"> <tr> <td>025</td><td>040</td><td>050</td><td>065</td><td>080</td><td>100</td> </tr> </table>	025	040	050	065	080	100
025	040	050	065	080	100						
					Pulgadas <table border="1" style="margin-left: auto; margin-right: auto;"> <tr> <td>010</td><td>112</td><td>200</td><td>212</td><td>300</td><td>400</td> </tr> </table>	010	112	200	212	300	400
010	112	200	212	300	400						
					Metric <table border="1" style="margin-left: auto; margin-right: auto;"> <tr> <td>042</td><td>053</td><td>063</td><td>073</td><td>083</td><td>104</td> </tr> </table>	042	053	063	073	083	104
042	053	063	073	083	104						
					CÓDIGO CONEXIONES 00 - Soldar/soldar 10 - Macho/soldar 11 - Macho/Macho 13 - Macho/tuerca 18 - Macho/brida cuadrada/Metric 30 - Tuerca/soldar 33 - Tuerca/tuerca						
					CÓDIGO FIGURA 64						
					MATERIAL V.BOLA - AISI-304 2 - AISI-316						



The inspector or user will be responsible for the assembly, installation, starting and operation of the valve with or without pneumatic operation.

3.4. LOCATION.

This equipment is suitable for his use in food process.

Place the valve/actuator in order to facilitate inspections and checks. Leave sufficient space around the valve/actuator for an appropriate inspection, separation and maintenance (See Section 3.7.3). It is very important to be able to access the air-connection device of the actuator, even when in operation.

3.5. ASSEMBLY.

Once the location of the valve is defined, the pipe can be connected by welding the bodies of the valve or by means of accessories (connectors).

Excessive stress should be avoided during the assembly of the valves and special attention should be given to the following:

- Vibration which may be produced in the installation.
- Expansion that the pipes may undergo in case hot liquids circulate.
- Weight that the pipes can withstand.
- Excessive intensity of welding.

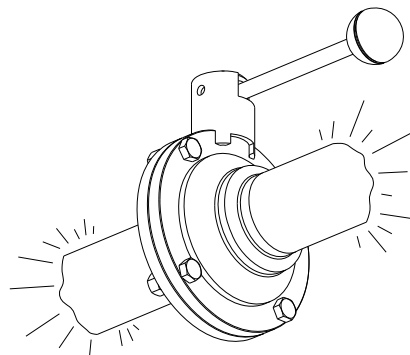

3.6. INSPECTION AND CHECKS.

Check the following before use:

- Open and close the valve several times to ensure that it operates correctly and check that the ball couples smoothly against the teflon guides.
- In case a pneumatic operation is incorporated, apply compressed air three or four times, checking that the opening and closing operation of the valve occurs easily.

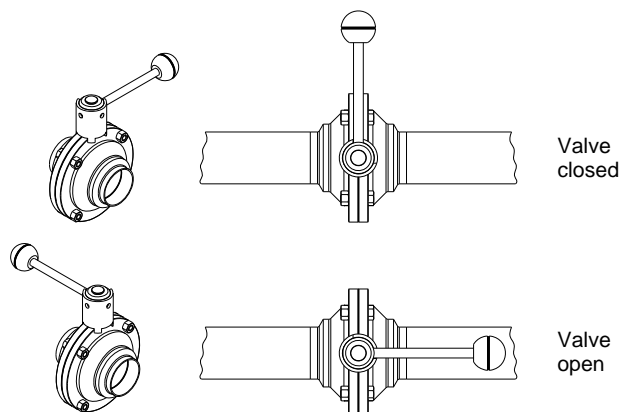

3.7. WELDING.



The welding work can only be carried out by persons qualified, trained and equipped with the necessary means to carry out this work.

Disassemble the valve before starting the welding work.

3.7.1. Weld/weld ball valve. Fig. 6400.

- Disassemble the valve as is indicated in the *Disassembly* section.
- Weld the two bodies of the valve to the pipes.
- On welding the two halves of the valve body, check that they can be axially separated (See elevation A) in order to disassemble the inside parts of the valve (ball, guides, shaft and seals).

DN	A
25-1"	36
40-1 1/2"	47
50-2"	59
65-2 1/2"	76
80-3"	92
100-4"	112

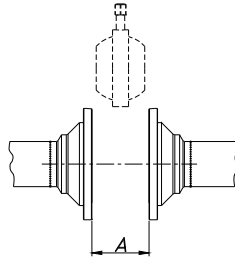

3.7.2. Valve with pneumatic operation.

In case of a valve with pneumatic operation, it is very important to maintain a minimum distance (elevation B) which allows disassembling the actuator. In this case, it is relevant to differentiate when the actuator has a control head (elevation C).

- Vertical pneumatic actuator

DN	B	C
	With pneumatic actuator	With pneumatic actuator and control head
25-1"	280	325
40-1 1/2"	280	325
50-2"	285	330

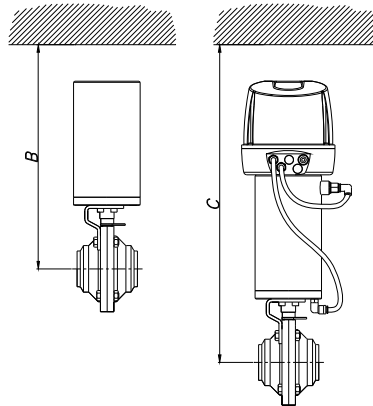

- Horizontal pneumatic actuator

DN	B	C
	With pneumatic actuator SE / DE	With pneumatic actuator and control head SE / DE
25-1"	245 / 245	365 / 365
40-1 1/2"	275 / 255	395 / 375
50-2"	285 / 285	405 / 405
65-2 1/2"	315 / 295	435 / 415
80-3"	315 / 305	435 / 425
100-4"	330 / 330	450 / 450

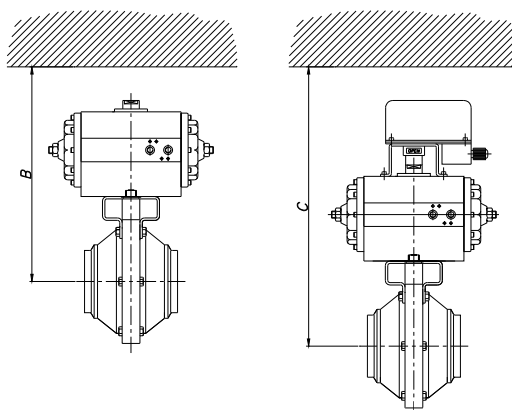

- Stainless horizontal pneumatic actuator

DN	B	C
	With pneumatic actuator SE / DE	With pneumatic actuator and control head SE / DE
25-1"	245 / 245	365 / 365
40-1 1/2"	275 / 255	395 / 375
50-2"	285 / 285	405 / 405
65-2 1/2"	315 / 295	435 / 415
80-3"	315 / 305	435 / 425
100-4"	330 / 330	450 / 450

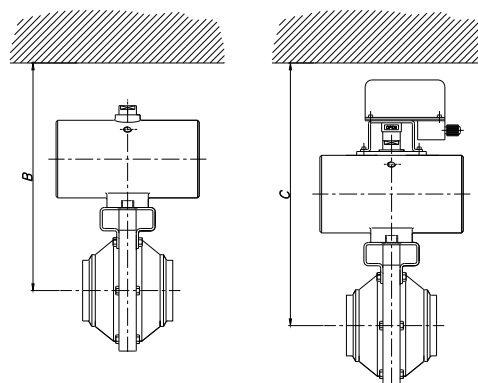

3.8. AIR CONNECTION TO ACTUATOR.

- Connect and check the air connections (BSP 1/8" thread, for vertical and horizontal actuator with stainless coating) according to double- or single-effect needs.
- For the horizontal actuator, the air connection should be carried out according to NAMUR/DIN 228/1.
- Correctly orientate the actuator and the ball depending on whether an NO/NC actuator is required. One solution or the other can be obtained on turning the ball.
- Mind the quality of the compressed air according to the specifications described in chapter 8 Technical Specifications.

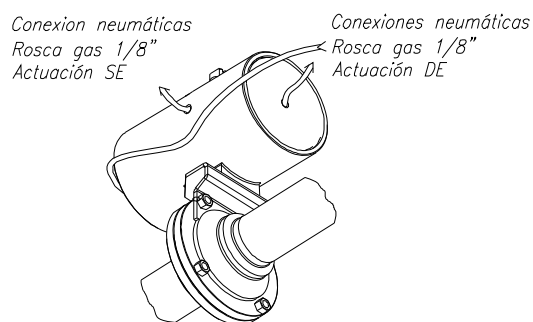
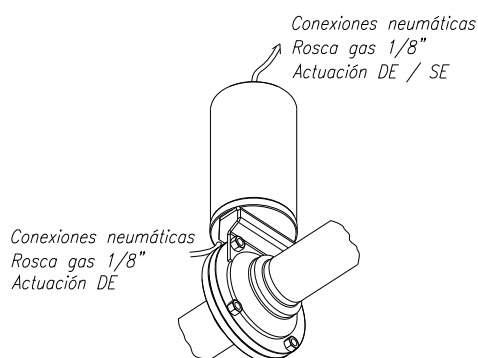

4. Start-up

The start-up of the valve (with or without actuator) can be carried out if the instructions indicated in Chapter 3 – *Receiving and Installation* are followed.

4.1. START-UP.



Before start-up, the responsible persons should be duly informed of the operation of the valve/actuator and the safety instructions to be followed. This instruction manual should be available to personnel at all times.

The following should be taken into consideration before starting-up the valve/actuator:

- Check that the pipe and valve are completely free from possible traces of welding or other foreign matter. Carry out the cleaning of the system if required.
- Verify the smooth operation of the valve. If necessary, lubricate with special grease or soapy water.
- If the valve is supplied with actuator, ensure that the alignment of the valve shaft with the actuator shaft allows for a smooth operation.
- Check that the compressed air pressure at the intake to the actuator is that indicated in the Technical Specifications (*Chapter 8*).
- Mind the quality of the compressed air according to the specifications described in chapter 8 Technical Specifications.
- Control possible leaks and check that all the pipes and connections are watertight and free from leaks.
- Operate the valve.

4.2. OPERATION.



Do not modify the operating parameters for which the valve/actuator has been designed without written prior authorisation from INOXPA.

Do not touch the moving parts of the coupling between the actuator and the valve when the actuator is connected to the compressed air.



¡Danger of burns! Do not touch the valve or pipes when hot liquids are circulating or when cleaning and/or sterilisation are being carried out.

4.2.1. Operation with two-position handlever.

- Allows operating the valve manually in the on/off position.
- Pull the handlever outward.
- Turn the handlever 90° while pulling at the same time.

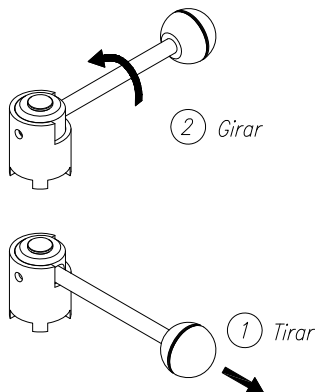

5. Troubleshooting

PROBLEM	CAUSE/EFFECT		SOLUTION
EXTERNAL LEAK. THE PRODUCT LEAKS THROUGH THE SHAFT	The main seal is worn or deteriorated.		<ul style="list-style-type: none"> • Replace the seals. • Replace the seals with others of different material and more appropriate for the product.
INTERNAL LEAK OF THE PRODUCT (VALVE CLOSED)	Normal wear of the guides and seals.		<ul style="list-style-type: none"> • Replace the seals.
	Premature wearing of the seals	Watertight seal worn or affected by the product. Excessive pressure in the line. Working temperature excessively high (assembly nuts and bolts) Loss of watertightness (vibration). High operating period (number of actuations/hour).	<ul style="list-style-type: none"> • Replace the seals with others of different material and more appropriate for the product. • Tighten any loose components. • Clean frequently. • Reduce opening/closing frequency of the valve.
VALVE JERKING	Seals jamming.		<ul style="list-style-type: none"> • Lubricate with soapy water or lubricant compatible with the material of the seal and with the product.
	The actuator does not handle the valve efficiently.		<ul style="list-style-type: none"> • Check the compressed air supply pressure. • Replace with larger size pneumatic actuator.
	Excessive pressure in the line.		<ul style="list-style-type: none"> • Check the pressure in the installation and adjust if necessary.
VALVE DOES NOT OPEN/CLOSE	Deformation of sealing joint. Incorrect operation of the actuator. Worn actuator components. Dirt in actuator.		<ul style="list-style-type: none"> • Replace the seals with others of different quality, if prematurely deteriorated. • Replace from NC to NO. • Check the actuator. • Check the compressed air pressure.
SURGE	The valve closes too fast.		<ul style="list-style-type: none"> • Adjust the closing speed of the actuator (with a flow regulator).

6. Maintenance

6.1. GENERAL INFORMATION

This valve, as well as any other machine, requires maintenance. The instructions contained in this manual cover the identification and replacement of spare parts. The instructions have been prepared for maintenance personnel and for those persons responsible for the supply of spare parts.



Carefully read Chapter 8. *Technical Specifications*.

All replaced material should be duly eliminated/recycled according to the directives in effect in the area.

The assembly and disassembly of the valves (with or without pneumatic operation) should only be carried out by qualified personnel.

Before beginning the maintenance work, ensure that the compressed air is disconnected and the pipes are not pressured.

6.2. MAINTENANCE.

The following is recommended for an appropriate maintenance:

- A regular inspection of the valve, of the actuator and its components.
- Keep a record of the operation of each valve, noting any incident.
- Always have spare seals in stock.

During maintenance, pay particular attention to the danger indications indicated in this manual.



Do not touch moving parts when the actuator is connected to the compressed air.

The valve and pipes should not be pressurised during maintenance.

The valve should not be hot during maintenance. ¡Danger of burns!

The springs are not protected on disassembling the actuator for reasons of maintenance/repair.



For the correct upkeep of the teflon guides, during long periods without operation, the ball should be always be in the closed or open position. Never leave the valve in half operation.

6.2.1. Maintenance of the seals.

REPLACEMENT OF SEALS	
Preventive maintenance	Replace after twelve (12) months.
Maintenance after a leak	Replace at the end of the process.
Scheduled maintenance	Regularly check for the absence of leaks and the smooth operation of the valve. Keep a record of the valve. Use statistics to plan inspections.
Lubrication	During the assembly, apply lubricants compatible with the material of the seal. See the following table.

SEAL COMPONENT	LUBRICANT	Class NLGI DIN 51818
NBR/ FPM/ VMQ	Klübersynth UH 1 64-2403	3
EPDM/ NBR/ FPM	PARALIQ GTE 703	3

The time interval between each preventive maintenance may vary according to the working conditions to which the valve is submitted: Temperature, pressure, number of operations per day, type of cleaning solutions used, etc.

6.2.2. Storage

The storage of the valves should be carried out in an enclosed area, under the following conditions:

- Temperature from 15°C to 30°C
- Relative humidity <60%

Storage of the equipment in the open air is **NOT** allowed.

6.2.3. Spare parts

To request spare parts, it is necessary to indicate the type of valve, the position and the description of the part which can be found in the Technical Specification chapter. In case of pneumatic actuators, indicate the type and manufacturing number which are noted in the nameplate and engraved on the body of the valve.

6.3. CLEANING.



The use of aggressive cleaning products such as caustic soda and nitric acid may cause burns to the skin.

Use rubber gloves during the cleaning process.



Always use protective goggles.

6.3.1. Automatic CIP (cleaning-in-place)

If the valve is installed in a system provided with the CIP process, its disassembly will not be required.

Cleaning solutions for CIP processes.

Only use clear water (free from chlorine) to mix with the cleaning agents:

a) Alkaline solution: 1% by weight of caustic soda (NaOH) at 70°C (150°F)

1 Kg NaOH + 100 l. of water = cleaning solution

o

2.2 l. NaOH at 33% + 100 l. of water = cleaning solution

b) Acid solution: 0.5% by weight of nitric acid (HNO₃) at 70°C (150°F)

0.7 litres HNO₃ at 53% + 100 l. of water = cleaning



Control the concentration of cleaning solutions; it may cause the deterioration of the watertight seals of the valve.

To eliminate the remains of cleaning products, ALWAYS carry out a final rinse on completion of the cleaning process.



Before beginning the disassembly and assembly work, clean the valve inside as well as outside. Disconnect the air from the actuator.

6.3.2. Automatic SIP (sterilization-in-place)

The process of sterilization with steam is applied to all the equipment including the pigging.



Do NOT start the equipment during the process of sterilization with steam.

The parts/materials suffer no damage if the indications specified in this manual are observed.

No cold liquid can enter the equipment till the temperature of the equipment is lower than 60°C (140°F).

Maximum conditions during the SIP process with steam or overheated water

- a) **Max. temperature:** 140°C / 284°F
- b) **Max. time:** 30 min
- c) **Cooling:** Sterile air or inert gas
- d) **Materials:** EPDM / PTFE (recommended)
FPM / NBR / VMQ (not recommended)

7. Assembly and disassembly



Proceed with caution. There is danger of personal injury.

The assembly and disassembly of the valves (with or without pneumatic operation) should only be carried out by qualified personnel.

7.1. DISASSEMBLY/ASSEMBLY OF THE VALVE WITH TWO-POSITION HANDLEVER.

Disassembly

1. Remove the plug (7) located in the upper part of the handlever (11A).
2. Unscrew the screw (23) and remove the entire handlever (11A+55)
3. Remove the bolts (26) and nuts (22) which connect the two sides.
4. Separate the sides (2) and remove the ball (3) with the seal (5).
5. Remove the guides (11) and O-rings (20) from the sides (2).
6. Disassemble the ball (3) and shaft (8) seal (5).

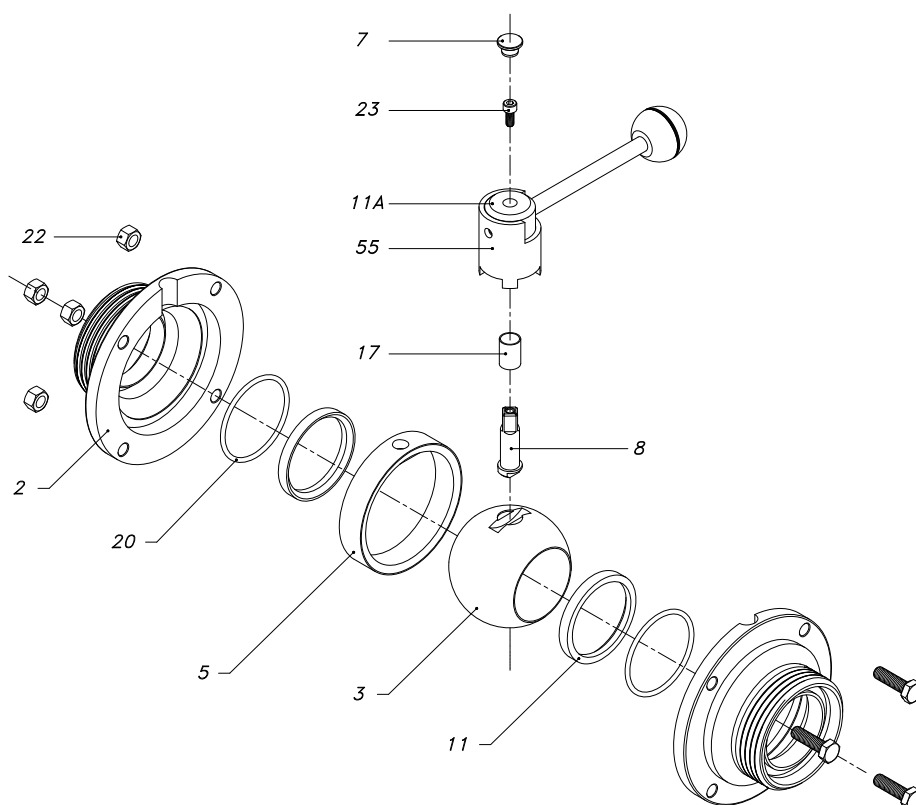

Assembly

1. Lubricate the ball shaft and seal with the appropriate grease (See Section [6.2.1 Maintenance of Seals](#)).
2. Install the seal (5) in the shaft (8) and ball (3).
3. Install the guides (11) and O-rings (20) in the sides (2) and lubricate.
4. Assemble the ball, shaft and seal assembly, between the two sides (2). CAUTION! On mounting the ball, shaft and seal assembly in the sides, leave the ball in the open or closed position to prevent damaging the guides.
5. Install the bolts (23B) and nuts (26), tighten according to the tightening torque indicated in this manual (See page 8.1).
6. Insert the core (11A) in the guide bushing (55) and install the arm of the handlever in the open position (aligned with the through hole of the ball).
7. Mount the handlever in the ball shaft and tighten the screw (23).
8. Install the plug in the upper part (7) of the handlever.



Before starting the valve, open and close it several times to check that the ball seats smoothly against the teflon guides.



The following tools are required to disassemble the valve:

- 4 mm Allen wrench
- Two 13 mm fixed wrenches

7.2. DISASSEMBLY/ASSEMBLY OF VALVE WITH VERTICAL PNEUMATIC ACTUATOR

Assembly

1. Disconnect the compressed air from the actuator.
2. Loosen the two bolts (26) and nuts (22) which connect the actuator support (21) with the sides.
3. Separate the support/actuator assembly from the sides.
4. Remove the screws (23) and separate the support (21) from the actuator (10).
5. Remove the on/off (58) position indicator.
6. Remove the bolts (26) and nuts (22) which connect the two sides.
7. Separate the sides (2) and remove the ball, shaft and seal (3+8+5).
8. Disassemble the seal (5) from the ball (3).
9. Remove the guides (11) and O-rings (20) from the sides (2).

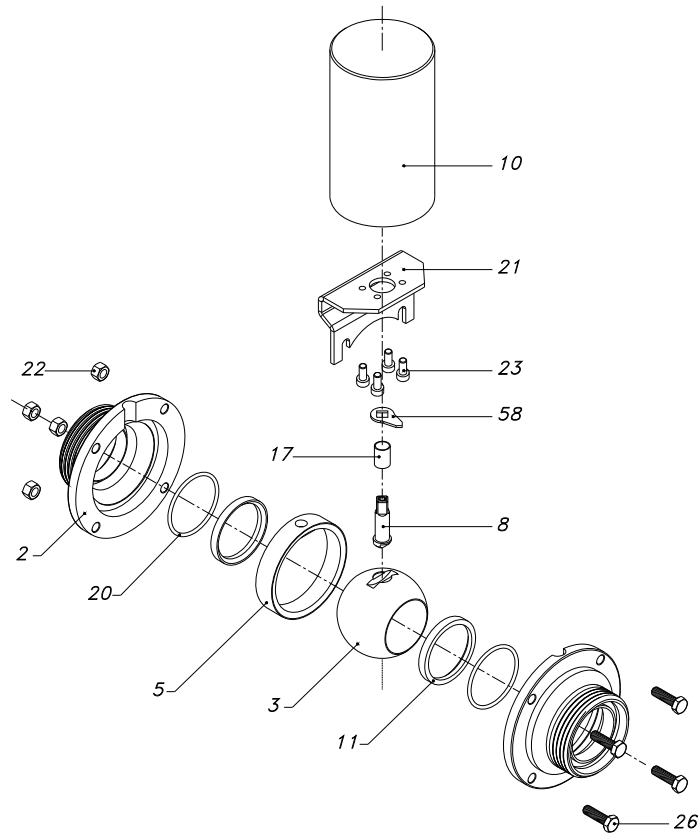

Assembly

10. Lubricate the shaft of the ball and seal with the appropriate grease (See Section [6.2.1 Maintenance of Seals](#)).
11. Insert the shaft (8) in the orifice of the seal (5). Place this assembly (8+5) in the ball (3).
12. Install the O-rings (20) and guides (11) in the sides and lubricate them.
13. Mount the ball, shaft and seal assembly (3+8+5), between the two sides (2). **iCAUTION!** Mount the ball in the fully open or closed position to avoid damaging the guides (11).
14. Loosely tighten the bolts (26) and nuts (22).
15. Situate the position indicator (58) in the ball shaft (8). Place it in the open or closed position, according to how the ball (3) is mounted.
16. Mount the support (21) in the actuator and tighten the bolts (23).
17. Mount the actuator with the support in order that it penetrates the ball shaft according to the instructions of the following section.
18. Tighten the bolts (26) and nuts (22) according to the tightening torque indicated in this manual.



Before starting the valve, open and close it several times to check that the ball seats smoothly against the teflon guides.



The following tools are required to disassemble the valve:

- 4 mm Allen wrench
- Two 13 mm fixed wrenches

7.3. SEAL ASSEMBLY.



Carry out the assembly with care, avoiding any deterioration of the seal.
 Ensure that the parts are in perfect order, free from any dirt and lubricated.

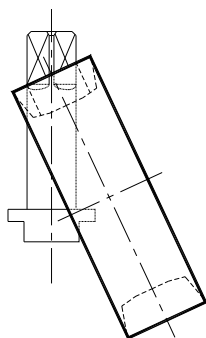

❶ Insert the ball shaft from the upper part, in the orifice of the seal.

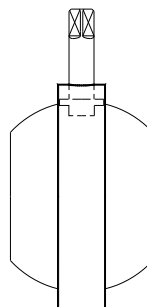

❷ Place the shaft-seal assembly in the ball. Match up the lower surfaces of the shaft with those of the ball housing.

7.4. ACTUATOR ASSEMBLY OPTIONS.

NC (Normally Closed) single effect.

The ball (3) and the position indicator (58) should be in the closed position (See Figure 1).

NO (Normally Open) single effect.

The ball (3) and the position indicator (58) should be in the open position (See Figure 2).

A/A double effect.

The ball (3) and the position indicator (58) should be in the open position (See Figure 3).

Before assembly, supply compressed air in the lower connection of the actuator.

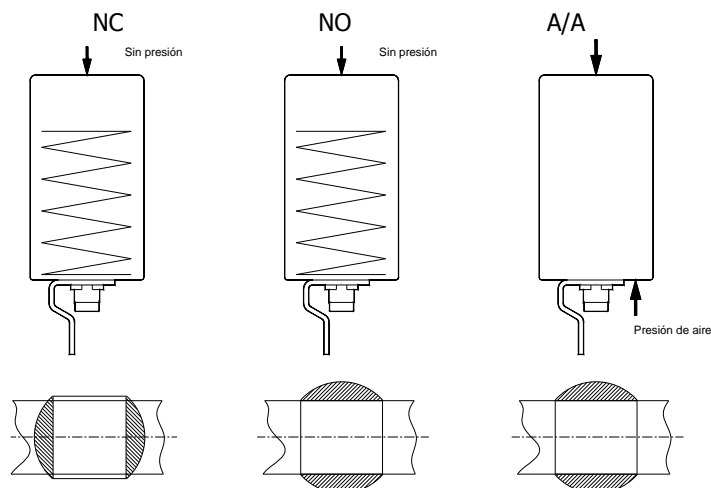

Figure 1

Figure 2

Figure 3

7.5. VALVE POSITION.

To check the valve position, open or closed, during the assembly-disassembly or change of handlever-actuator, the position of the shaft (17) should be verified.

The upper part of the shaft (17) is provided with a slot. This indicates the valve position:

- Open: When the slot is in line with the fluid circulation.
- Closed: When the slot cuts off, on an imaginary basis, the fluid circulation.

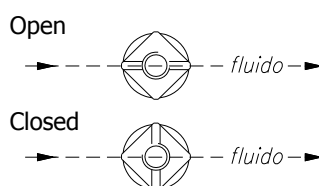

8. Technical Specifications

8.1. TECHNICAL SPECIFICATIONS

VALVE GENERAL DATA								
Maximum working pressure	DN-25/65 DN-1"2 1/2" 10 bar				DN-80/100 DN-3"/4" 8 bar			
Maximum working temperature	121°C (250°F) EPDM standard seals (Other qualities of seals will be adapted for higher temperatures)							
Operating torque [N.m.] (dry tests)	25-1"	40-1/2"	50-2"	2 1/2"	65	3"	80	100-4"
	8	10	14	15	18	18	20	25
Surface finish	In contact with the product: Ra ≤ 0,8 µm External surfaces: Machined finish (turned on lathe)							

VALVE MATERIALS	
Parts in contact with the product	AISI 316L (1.4404) AISI 304L (1.4306)
Other steel parts	AISI 304 (1.4301)
Seals in contact with the product	EPDM (Standard) - NBR - VITON - SILICONE.
Surface finish	Parts in contact with the product.< Ra. 0,8µm
Type of connections	DIN 11851 (Standard) Welding, FIL-IDF, BS-RJT, SMS, Clamp, Flanges, Macon.

VERTICAL PNEUMATIC ACTUATOR GENERAL DATA	
Compressed air consumption/cycle	Single effect: 0.25 litre/double effect: 0.5 litre
Compressed air pressure (Actuator)	6-8 bar (87-116 PSI) Single effect 4-6 bar (58-87 PSI) Double effect
Control air	According to DIN/ISO 8573.1: <ul style="list-style-type: none"> - <u>Solid particle content</u>: Quality class 3 / Particle size max. 5 micres / particle density max. 5 mg/m³ - <u>Water content</u>: Quality class 4 / max. dew point +2°C If the valve is used at higher altitudes or at low ambient temperatures, the dew point must be adapted accordingly - <u>Oil content</u>: Quality class 5, preferably oil free / max. 25 mg. oil in 1 m³ air
Weight	Single effect 3.2 kg Double effect 2.5 kg
Turning angle	90°
Turning moment	35Nm (single effect) 60Nm (double effect)
Continuous working temperature	-20°C to +50°C
Air connections	R1/8" (BSP)

HORIZONTAL PNEUMATIC ACTUATOR GENERAL DATA	
<i>Compressed air consumption/cycle</i>	T.005: 0.36 litre T.008: 0.8 litre T.012: 1.2 litres T.020: 1.8 litres.
<i>Compressed air pressure (Actuator)</i>	4-7 bar (60-100 PSI) Single effect 4-7 bar (60-100 PSI) Double effect
<i>Control air</i>	According to DIN/ISO 8573.1: <ul style="list-style-type: none"> - <u>Solid particle content</u>: Quality class 3 / Particle size max. 5 micres / particle density max. 5 mg/m³ - <u>Water content</u>: Quality class 4 / max. dew point +2°C If the valve is used at higher altitudes or at low ambient temperatures, the dew point must be adapted accordingly - <u>Oil content</u>: Quality class 5, preferably oil free / max. 25 mg. oil in 1 m³ air
<i>Weight</i>	T.005: 1.75 kg T.008: 2.85 kg T.012: 4.25 kg T.020: 5.3 kg.
<i>Turning angle</i>	90°
<i>Turning moment</i>	S/E (6bar). T.005=10Nm. T.008=27Nm. T.012=39Nm. T.020=63Nm. D/E (6bar). T.005=33Nm. T.008=70Nm. T.012=105Nm. T.020=160Nm.
<i>Continuous working temperature</i>	-20°C to +50°C
<i>Air connections</i>	NAMUR/DIN 228/1

Tools/Side assembly tightening torque

Valve size	DN-25 / 125 DN-1" / 4"	DN-150 DN-6"
DIN 37110 fixed wrench	13	17
Tightening torque	21 Nm	42 Nm

8.2. MANUAL VALVE DIMENSIONS

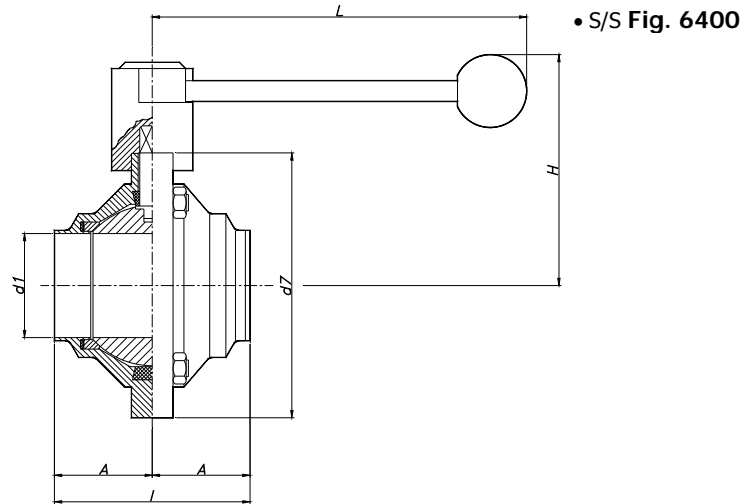

DN	d1	d7	A	I	H	L	AISI-316L
25	26	94	36	72	95	150	26400025EB
40	38	114	42	84	104	150	26400040EB
50	50	131	49	98	112	150	26400050EB
65	66	158	60	120	126	180	26400065EB
80	81	181	70	140	142	250	26400080EB
100	100	209	82	164	156	250	26400100EB

DN	d1	d7	A	I	H	L	AISI-316L
1"	22,1	94	36	72	95	150	26400010EB
1 1/2"	34,9	114	42	84	104	150	26400112EB
2"	47,6	131	49	98	112	150	26400200EB
2 1/2"	60,3	158	60	120	126	180	26400212EB
3"	72,9	181	70	140	142	250	26400300EB
4"	97,4	209	82	164	156	250	26400400EB

8.3. DIMENSIONS WITH VERTICAL PNEUMATIC OPERATION

Vertical pneumatic (single effect/double effect)

DN	Ø d1	H	H 1	Act.	Ø d2
25	26	213	358	T1	Ø 76
32	32	216	361		
40	38	223	368		
50	50	251	383	T2	Ø 90
65	66	315	448	T3	Ø 133
80	81	326	459		
100	100	340	473		

DN	Ø d1	H	H 1	Act.	Ø d2
1"	22,1	213	358	T1	Ø 76
1 1/2"	34,9	223	368		
2"	47,6	251	383	T2	Ø 90
2 1/2"	60,3	315	448	T3	Ø 133
3"	72,9	326	459		
4"	97,4	340	473		

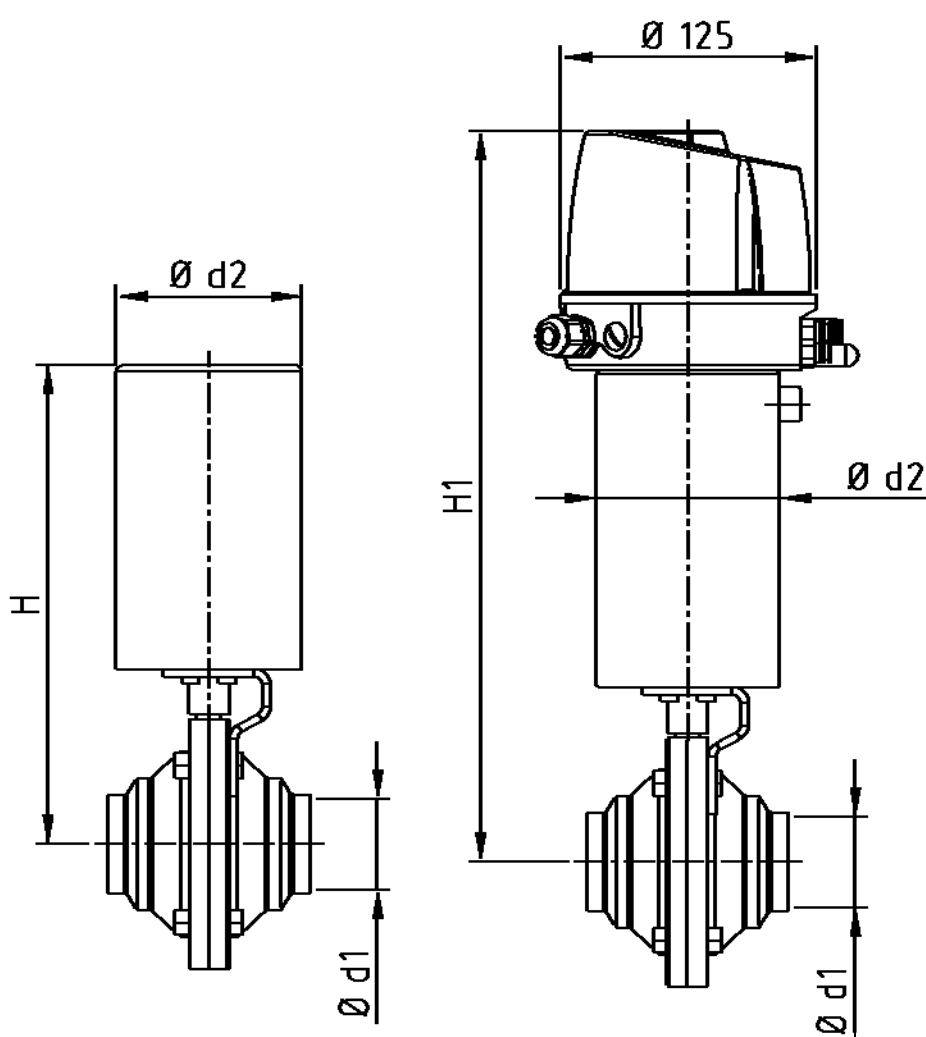

Horizontal pneumatic (single effect/double effect)

DN	d1	d5Rd	I	J	H	A	B	C
25	26	52x1/6"	90	102	193	36	36	72
40	38	65x1/6"	111	225	223	42	42	84
50	50	78x1/6"	111	225	232	49	49	98
65	66	95x1/6"	132	231	265	60	60	120
80	81	110x1/4"	132	231	266	70	70	140
100	100	130x1/4"	132	280	280	82	82	164

(Double effect)

25	26	52x1/6"	90	102	193	36	36	72
40	38	65x1/6"	90	102	203	42	42	84
50	50	78x1/6"	111	225	232	49	49	98
65	66	95x1/6"	111	225	245	60	60	120
80	81	110x1/4"	111	225	252	70	70	140
100	100	130x1/4"	132	231	280	82	82	164

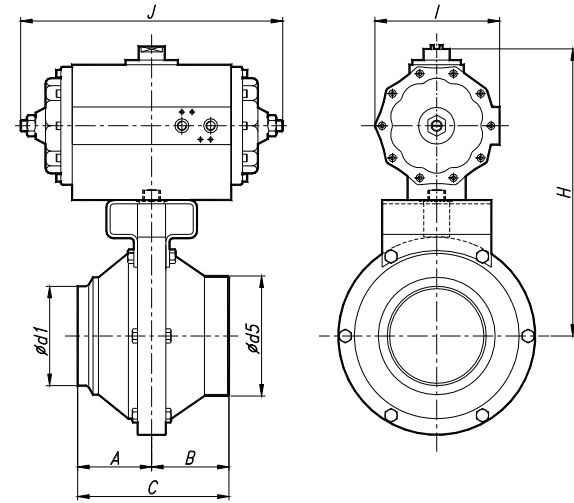

Stainless horizontal pneumatic (single effect/double effect)

DN	d1	d5Rd	I	J	H	A	B	C
25	26	52x1/6"	179	93	230	36	36	72
40	38	65x1/6"			240	42	42	84
50	50	78x1/6"			245	49	49	98
65	66	95x1/6"	225	113	280	60	60	120
80	81	110x1/4"			290	70	70	140
100	100	130x1/4"			305	82	82	164

(Double effect)

25	26	52x1/6"	187	93	230	36	36	72
40	38	65x1/6"			240	42	42	84
50	50	78x1/6"			245	49	49	98
65	66	95x1/6"	225	113	280	60	60	120
80	81	110x1/4"			290	70	70	140
100	100	130x1/4"			305	82	82	164

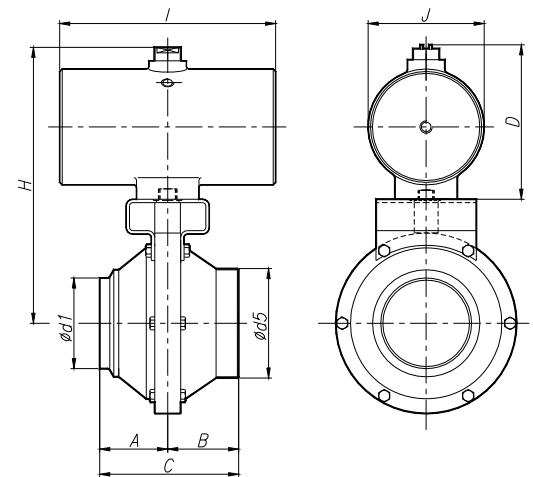

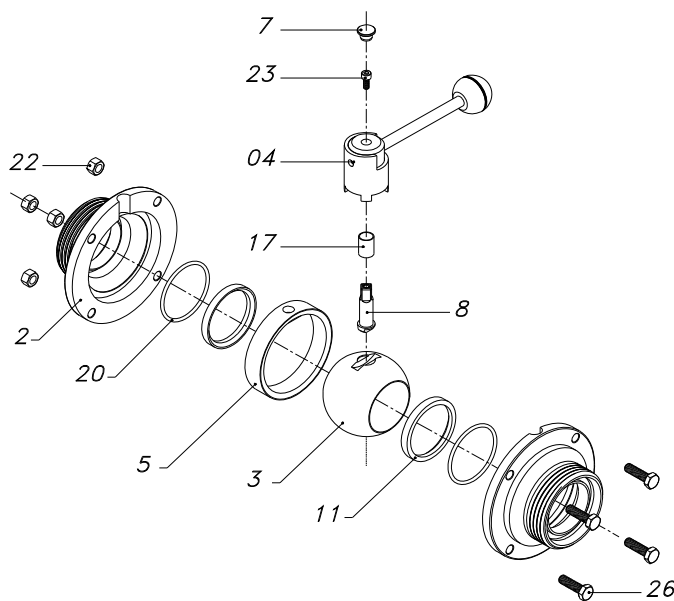

8.4. SECTION AND PARTS LIST

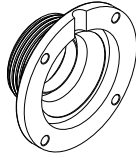
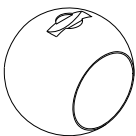
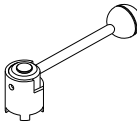

POSITION	DESIGNATION	MATERIAL	QUANTITY
2	Side	AISI 304L/316L	2
3	Ball	AISI 304/316	1
4	Handlever assembly	AISI 303	1
5	Seal	EPDM	1
8	Shaft	AISI 316L	1
11	Ball guide	PTFE	2
17	Guide bushing	PTFE	1
20	O-ring	EPDM	2
22	Hexagonal bolt	A-2	4/6
26	Nut	A-2	4/6

8.5. PARTS LISTS

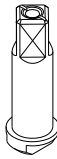
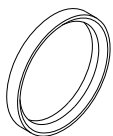
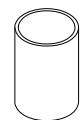
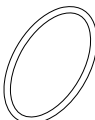
DN	02	03	04	05	08	11	17	20
								
25 1"	350187A 350214A	450576A	4510011	450572A	450575A.6	450573A	-	04028030
40 1 1/2"	350189C 350215C	450576C		450572C	450575B.6	450573C	450574A	04042030
50 2"	350190D 350216D	450576D		450572D		450573D		04054030
65 2 1/2"	350191E 350217E	450576E	4510012	450572E	450575C.6	450573E		450574D
80 3"	350586F 350604F	450576I	4510014	451310F	450575D.6	450573F	04085040	
100 4"	350587G 350605G	450576J		451310G		450573G	04105040	

DN-80/100-3"/4" MODEL 96								
80 3"	350192F 350218F	450576F	4510013	450572F	450575D.0	450573F	450574B	04085040
100 4"	350193G 350219G			450572I		450573I		
		450576G		450572G		450573G		

* Recommended spare parts.

NOTES

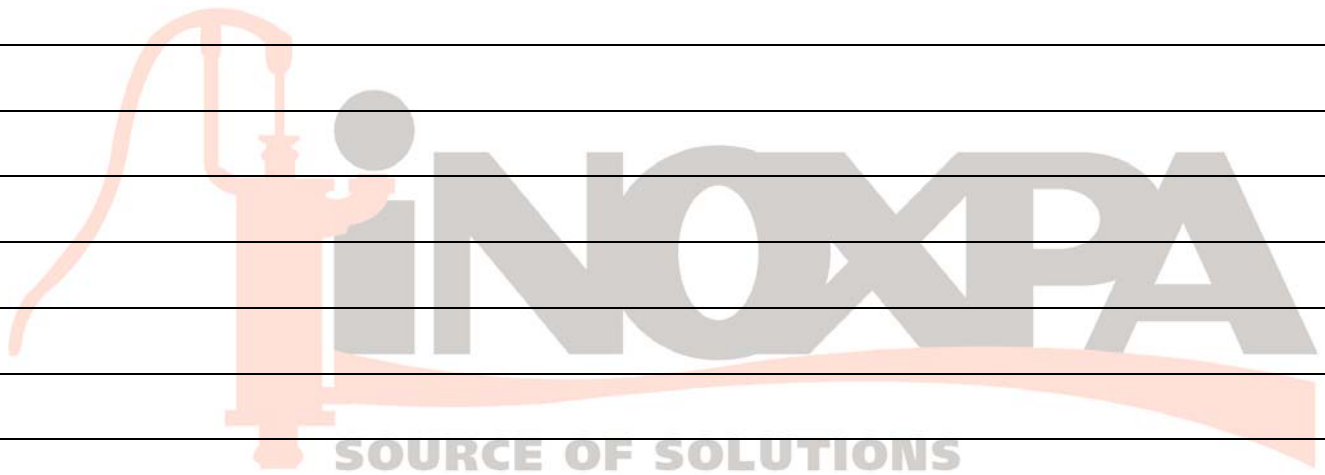

NOTES

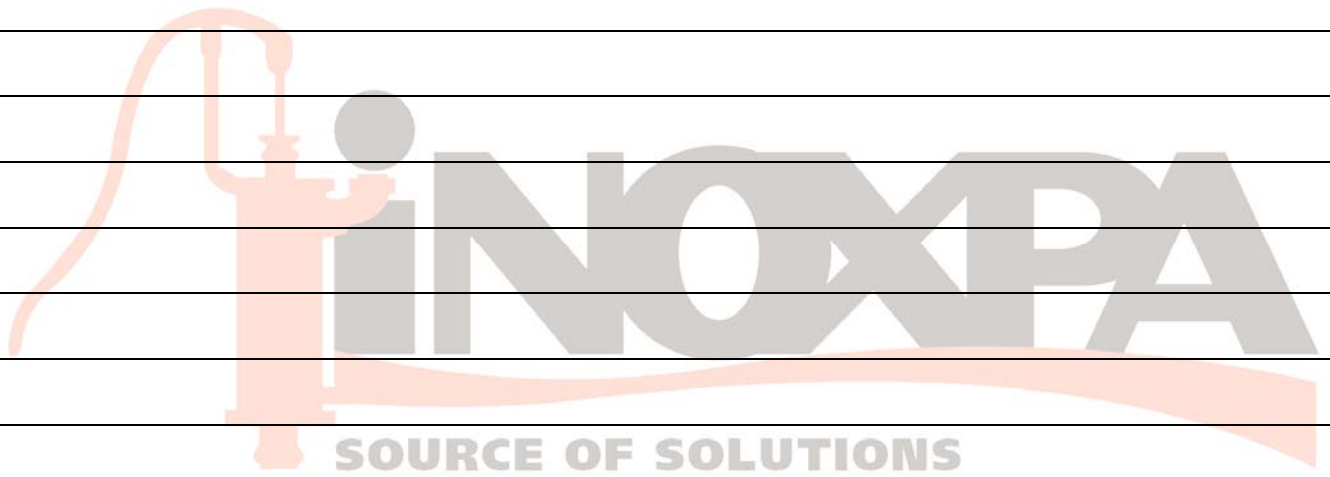

**INOXPA, S.A.**

c/ Telers, 54 – PO Box 174
17820 BANYOLES (GIRONA)
Tel: 34 972575200
Fax: 34 972575502
e-mail: inoxpa@inoxpa.com
www.inoxpa.com

DELEGACIÓN LEVANTE

PATERNA (VALENCIA)
Tel: 963 170 101
Fax: 963 777 539
e-mail: inoxpa.levante@inoxpa.com

LA CISTÉRNIGA (VALLADOLID)

Tel: 983 403 197
Fax: 983 402 640
e-mail: sta.valladolid@inoxpa.com

INOXPA SOLUTIONS LEVANTE

PATERNA (VALENCIA)
Tel: 963 170 101
Fax: 963 777 539
e-mail: isf@inoxpa.com

ST. SEBASTIEN sur LOIRE

Tel/Fax: 33 130289100
e-mail: inoxpa.fr@inoxpa.com

INOXPA ALGERIE

ROUIBA
Tel: 213 21856363 / 21851780
Fax: 213 21854431
e-mail: inoxpalgerie@inoxpa.com

INOXPA UK LTD

SURREY
Tel: 44 1737 378 060 / 079
Fax: 44 1737 766 539
e-mail: inoxpa-uk@inoxpa.com

INOXPA SKANDINAVIEN A/S

HORSENS (DENMARK)
Tel: 45 76 286 900
Fax: 45 76 286 909
e-mail: inoxpa.dk@inoxpa.com

**INOXPA SPECIAL PROCESSING
EQUIPMENT, CO., LTD.**

JIAXING (China)
Tel.: 86 573 83 570 035 / 036
Fax: 86 573 83 570 038

INOXPA WINE SOLUTIONS

VENDARGUES (FRANCE)
Tel: 33 971 515 447
Fax: 33 467 568 745
e-mail: frigail.fr@inoxpa.com /
npourtaud.fr@inoxpa.com

DELEGACIÓN NORD-ESTE /

BARBERÀ DEL VALLÈS (BCN)
Tel: 937 297 280
Fax: 937 296 220
e-mail: inoxpa.nordeste@inoxpa.com

DELEGACIÓN CENTRO

ARGANDA DEL REY (MADRID)
Tel: 918 716 084
Fax: 918 703 641
e-mail: inoxpa.centro@inoxpa.com

LOGROÑO

Tel: 941 228 622
Fax: 941 204 290
e-mail: sta.rioja@inoxpa.com

INOXPA SOLUTIONS FRANCE

GLEIZE
Tel: 33 474627100
Fax: 33 474627101
e-mail: inoxpa.fr@inoxpa.com

WAMBRECHIES

Tel: 33 320631000
Fax: 33 320631001
e-mail: inoxpa.nord.fr@inoxpa.com

INOXPA SOUTH AFRICA (PTY) LTD

JOHANNESBURG
Tel: 27 117 945 223
Fax: 27 866 807 756
e-mail: sales@inoxpa.com

S.T.A. PORTUGUESA LDA

VALE DE CAMBRA
Tel: 351 256 472 722
Fax: 351 256 425 697
e-mail: comercial.pt@inoxpa.com

IMPROVED SOLUTIONS

VALE DE CAMBRA
Tel: 351 256 472 140 / 138
Fax: 351 256 472 130
e-mail: isp.pt@inoxpa.com

INOXRUS

MOSCOW (RUSIA)
Tel / Fax: 74 956 606 020
e-mail: moscow@inoxpa.com

INOXPA UCRANIA

KIEV
Tel: 38 050 720 8692
e-mail: kiev@inoxpa.com

ZARAGOZA

Tel: 976 591 942
Fax: 976 591 473
e-mail: inoxpa.aragon@inoxpa.com

DELEGACIÓN STA

GALDACANO (BILBAO)
Tel: 944 572 058
Fax: 944 571 806
e-mail: sta@inoxpa.com

DELEGACIÓN SUR

JEREZ DE LA FRONTERA (CÁDIZ)
Tel / Fax: 956 140 193
e-mail: inoxpa.sur@inoxpa.com

CHAMBLY (PARIS)

Tel: 33 130289100
Fax: 33 130289101
e-mail: isf@inoxpa.com

INOXPA AUSTRALIA PTY (LTD)

MORNINGTON (VICTORIA)
Tel: 61 3 5976 8881
Fax: 61 3 5976 8882
e-mail: inoxpa.au@inoxpa.com

INOXPA USA, Inc

SANTA ROSA
Tel: 1 7075 853 900
Fax: 1 7075 853 908
e-mail: inoxpa.us@inoxpa.com

INOXPA ITALIA, S.R.L.

BALLO DI MIRANO – VENEZIA
Tel: 39 041 411 236
Fax: 39 041 5128 414
e-mail: inoxpa.it@inoxpa.com

INOXPA INDIA PVT. LTD.

Maharashtra, INDIA.
Tel: 91 2065 008 458
inoxpa.in@inoxpa.com

SAINT PETERSBURG (RUSIA)

Tel: 78 126 221 626 / 927
Fax: 78 126 221 926
e-mail: spb@inoxpa.com

In addition to our branch offices, INOXPA operates with an independent distributor network which encompasses a total of more than 50 countries throughout the world. For more information consult our web page: www.inoxpa.com Orientative information. We reserve the right to modify any material or characteristic without prior notice.