



# Alfa Laval ThinkTop® DeviceNet

Match any level of valve control for fluid handling in hygienic applications

## Introduction

The Alfa Laval ThinkTop® DeviceNet™ is a modular valve control unit that offers reliable, cost-effective operation and standard functionality for automated sensing and control of hygienic valves. ThinkTop DeviceNet provides real-time information about valve operating status 24/7 while boosting productivity and securing traceability.

## Application

The ThinkTop DeviceNet is designed to control the fluid handling process in hygienic applications across the dairy, food, beverage, biotechnology, pharmaceutical and many other industries.

## Benefits

- Reliable and accurate valve sensing and control
- Proven and inherently safe design
- Low total cost of ownership
- Watertight design
- Easy to operate

## Standard design

The ThinkTop DeviceNet valve sensing and control unit consists of a proven no-touch, set-and-forget sensor system with light-emitting diodes (LEDs), solenoid valves, and valve control sensor board for connection to any programmable logic controller (PLC) system with a DeviceNet interface. It fits on all Alfa Laval hygienic valves; no adapter is required.

Installation is straightforward. No special expertise or tools are required. To initiate manual setup, simply press a push-button startup sequence. Or set up without dismantling the control unit using the optional infrared (IR) keypad for remote control.

## Working principle

The sensor system accurately detects valve stem movement, the position of the valve at any given time, with an accuracy of  $\pm 0.1$ mm through the use of microchip sensors. To locate the current valve position, sensor chips inside the sensor board calculate the angle between the axial magnetic field produced by an indication pin mounted on the valve stem.

The solenoid valves receive signals from the PLC system to activate or deactivate the air-operated valve. It then transmits feedback signals indicating up to four valve positions and conditions back to the PLC system.

In the control unit, up to three electric solenoid valves can physically convert compressed air into mechanical energy to activate or deactivate the pneumatic valve actuator.



Each control unit fits any Alfa Laval hygienic valve and provides a tolerance band for valves to prevent product contamination and failure. This eliminates the need to re-adjust the sensors and boosts productivity.

LEDs conveniently display all the valve positions, solenoid activation, setup and local fault indication on the control unit.

## Certificates



## TECHNICAL DATA

Communication	
Interface:	DeviceNet
Supply voltage:	11 - 25 VDC
Class 4 messaging:	2 byte Polling
Baud rates:	125K, 250K, 500K
Default slave address:	63

Sensor board	
Max current consumption:	45mA
Feedback signal #1:	Closed valve
Feedback signal #2:	Open valve
Feedback signal #3:	Seat-lift 1
Feedback signal #4:	Seat-lift 2
Feedback signal #5:	Status
Valve tolerance band options	5
Default tolerance band:	± 5 mm
Sensor accuracy:	±0.1 mm
Stroke length:	0.1 - 80 mm

Solenoid valve	
Max current consumption:	45mA
Air supply:	300-900 kPa (3-9 bar)
Type of solenoids:	3/2-ways or 5/2-ways
Numbers of solenoids:	0-3
Manual hold override:	Yes
Throttle, Air in/out 1A, 1B:	0-100 %
Push-in fittings:	ø6 mm or 1/4"

## PHYSICAL DATA

Materials	
Steel parts:	Stainless steel and Brass
Plastic parts:	Blue Nylon PA 12
Seals:	Nitrile (NBR) rubber

Environment	
Working temperature:	-20 °C to +85 °C
Protection class:	IP66 and IP67
Protection class equivalent:	NEMA 4.4x and 6P

Cable connection	
Main cable gland:	PG11 (4 - 10 mm)
Max wire size:	0.75 mm <sup>2</sup> (AWG 19)
Optional cable gland:	PG7 (4 - 6,8 mm)

### Notel

For further information: See also ESE00355

The ThinkTop has Patented Sensor System, Registered Design and Registered Trademark owned by Alfa Laval

### Options

- Solenoid valve configuration
- Pneumatic tubing interface

### Accessories

- Remote programming (IR keypad)
- For upper seat-lift detection on Mixproof valves
  - External PNP sensors (Refer to Brackets and Inductive Sensors)
  - Cable gland PG7
  - External sensor bracket (Refer to Brackets and Inductive Sensors)
- Various cable options
- Threaded plate for indication pin on SRC, SMP-BC and i-SSV valves
- Special indication pin for Unique SSV-LS, Unique SSV High Pressure valve
- Adaptor for Unique SSSV valves

## Dimensions (mm)

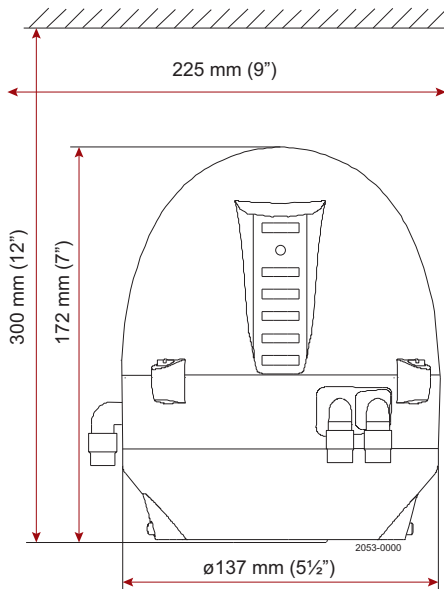

## DeviceNet features

Generic		Master/scanner	
		I/O Slave messaging supported by ThinkTop® DeviceNet	
Explicit peer to peer messaging	No	• Bit strobe No	No
I/O peer to peer messaging	No	• Polling	Yes
Configuration consistency value	No	• Cyclic	No
Faulted node recovery	No	• Change of state (COS)	No
Configuration method	EDS fil, Top46-7j	ThinkTop before 2012	
	EDS fil, T-Top RTA	ThinkTop after 2012	

## Electrical connection

P1	P2				
6	1	6	N/C	1	Power bus V- (Black)
7	2	7	N/C	2	CAN_L (Blue)
8	3	8	N/C	3	Drain (Bare)
9	4	9	N/C	4	CAN_H (White)
10	5	10	N/C	5	Power bus V+ (Red)
11	12	11	N/C	12	N/C
⊥	13	Earth	Earth	13	N/C
20	24	20	Solenoid com (Grey)	24	Seat-lift 1 "upper"
21	25	21	Solenoid 1 (Grey)	25	Seat-lift 2 "lower"
22	26	22	Solenoid 2 (Grey)	26	Supply +
23	27	23	Solenoid 3 (Grey)	27	Supply-

## DeviceNet bits assignment

For DeviceNet the following bit assignment can be used

Valve value		Valve command	
DI0	Feedback #1 Closed valve	DO0	Out #1 Not Connected
DI1	Feedback #2 Open valve	DO1	Out #2 Solenoid valve 1
DI2	Feedback #3 Seatlift 1	DO2	Out #3 Solenoid valve 2
DI3	Feedback #4 Seatlift 2	DO3	Out #4 Solenoid valve 3
DI4	Feedback #5 Status	DO4	Out #5 Not Connected
DI5	Feedback #6 Not Connected	DO5	Out #6 Not Connected
DI6	Feedback #7 Not Connected	DO6	Out #7 Not Connected
DI7	Feedback #8 Not Connected	DO7	Out #8 Not Connected

Alfa Laval reserves the right to change specifications without prior notification.

---

**How to contact Alfa Laval**

Contact details for all countries  
are continually updated on our website.  
Please visit [www.alfalaval.com](http://www.alfalaval.com) to  
access the information direct.