

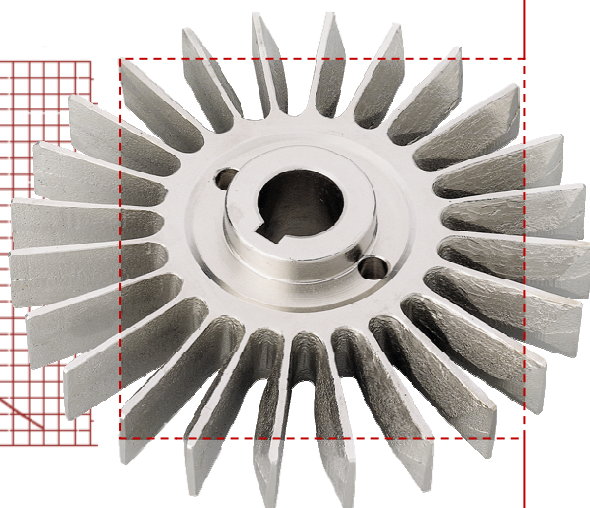

## CURVAS CARACTERÍSTICAS PERFORMANCE CURVES

# ASPIR

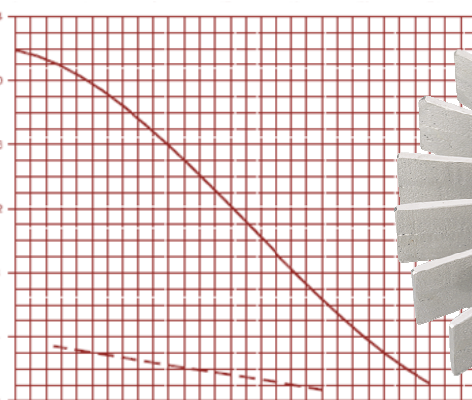
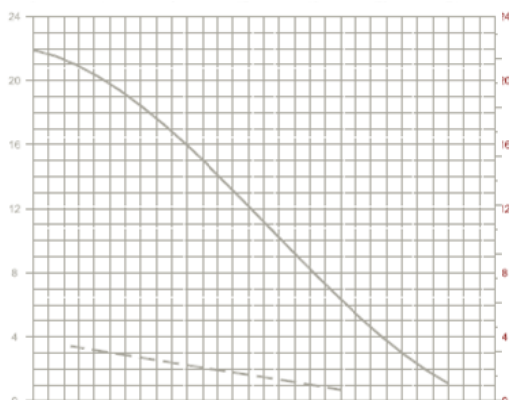

### INOXPA, S.A.

c/Telers, 54 Aptdo. 174

E-17820 Banyoles

Girona (Spain)

Tel.: (34) 972 57 52 00

Fax: (34) 972 57 55 02

inoxpa@inoxpa.com

www.inoxpa.com

ISO 9001

BUREAU VERITAS  
Certification



www.sksonline.com

01.400.12.0011

ED. 2010/04



# Contenidos / Contents

## 1450 rpm (50 Hz)

Área de selección / Performance chart .....	1
A-50.....	2
A-80 .....	3
A-150 .....	4
A-200.....	5

## 1750 rpm (60 Hz)

Área de selección / Performance chart .....	7
A-50.....	8
A-80 .....	9
A-150 .....	10
A-200.....	11





CURVAS CARACTERÍSTICAS  
PERFORMANCE CURVES

ÁREA DE SELECCIÓN  
PERFORMANCE CHART

Velocidad / Speed

1450 rpm (50 Hz)

Bomba / Pump

**ASPIR**

Rodete / Impeller

Estrella / Star-shaped

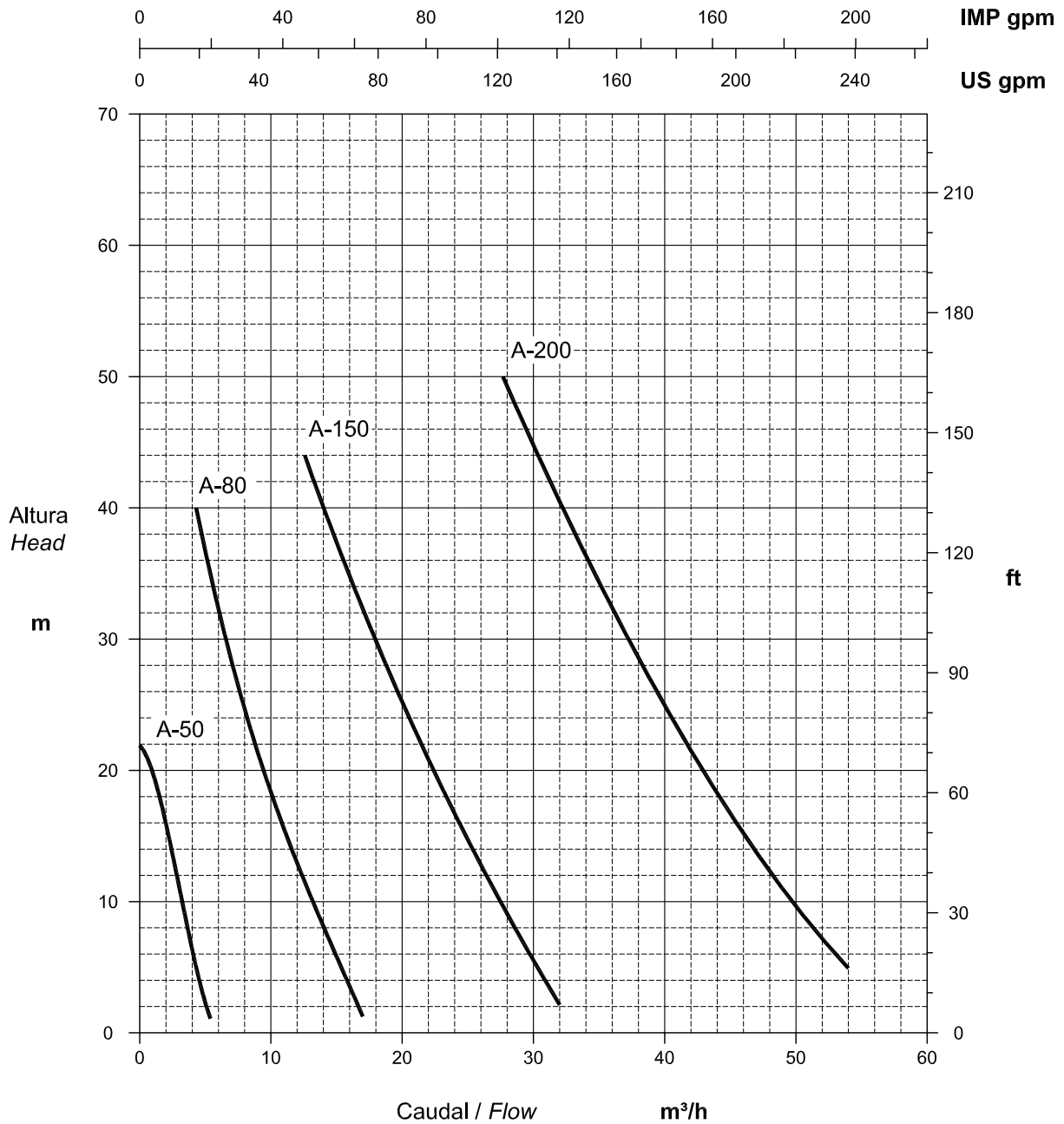

Los datos hacen referencia a agua limpia a 20°C / Performance data refer to clear water at 20°C

Tolerancia según ISO 9906:1999 Anexo A / Permissible tolerance ISO 9906:1999 Annex A



CURVAS CARACTERÍSTICAS  
PERFORMANCE CURVES

Rodete / Impeller Estrella / Star-shaped	Ø Boca asp. / Pump inlet DN-32	Bomba / Pump <b>A-50</b>
Ø Rodete / Ø Impeller 110 mm	Ø Boca imp. / Pump outlet DN-32	
Número palas / Number of blades 24	——— By-pass cerrado / closed - - - - By-pass abierto / opened	Velocidad / Speed 1400 rpm

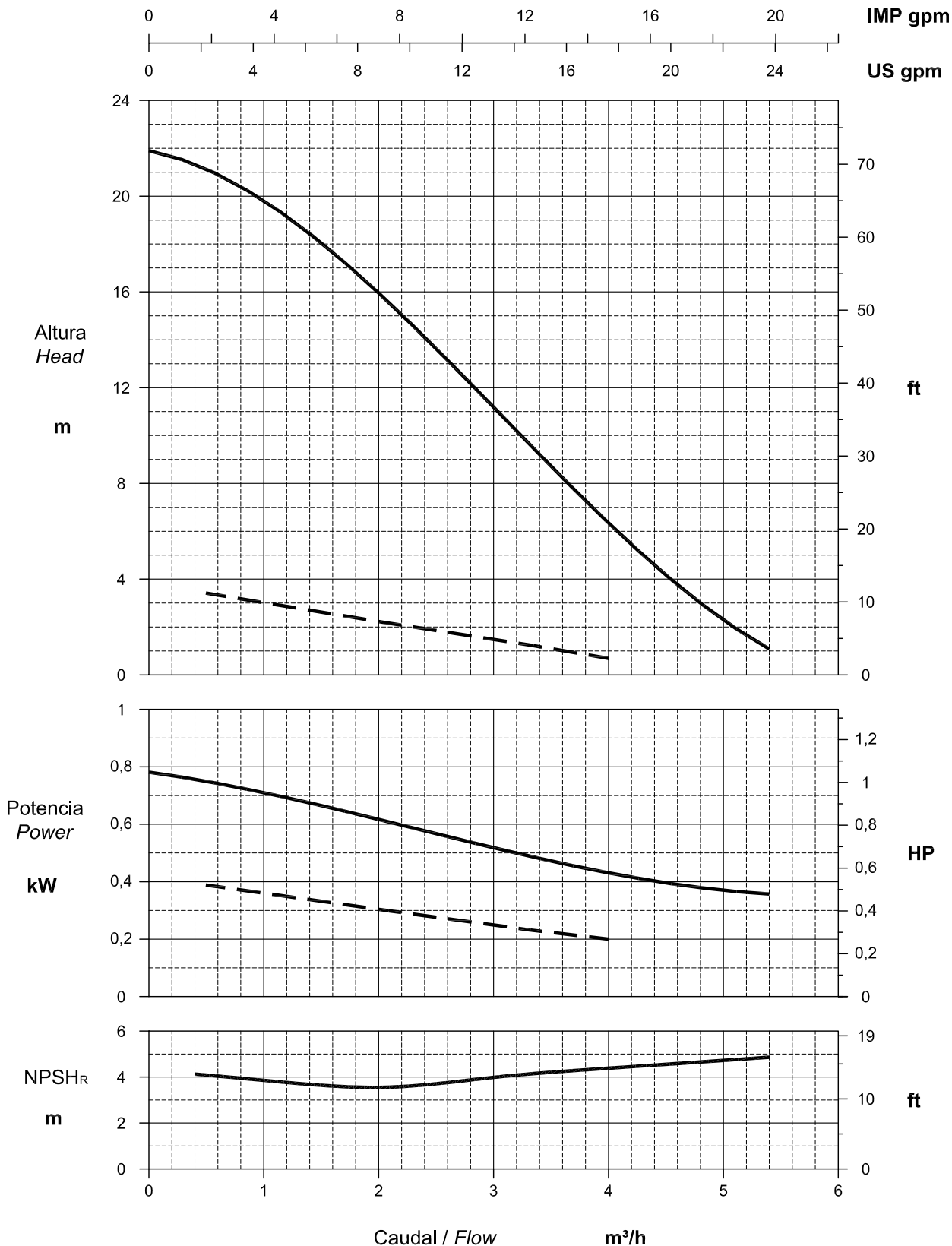

Los datos hacen referencia a agua limpia a 20°C / Performance data refer to clear water at 20°C

Tolerancia según ISO 9906:1999 Anexo A / Permissible tolerance ISO 9906:1999 Annex A



CURVAS CARACTERÍSTICAS  
PERFORMANCE CURVES

Rodete / Impeller Estrella / Star-shaped	Ø Boca asp. / Pump inlet DN-40	Bomba / Pump <b>A-80</b>
Ø Rodete / Ø Impeller 135 mm	Ø Boca imp. / Pump outlet DN-40	
Número palas / Number of blades 24	——— By-pass cerrado / closed - - - - By-pass abierto / opened	Velocidad / Speed 1450 rpm

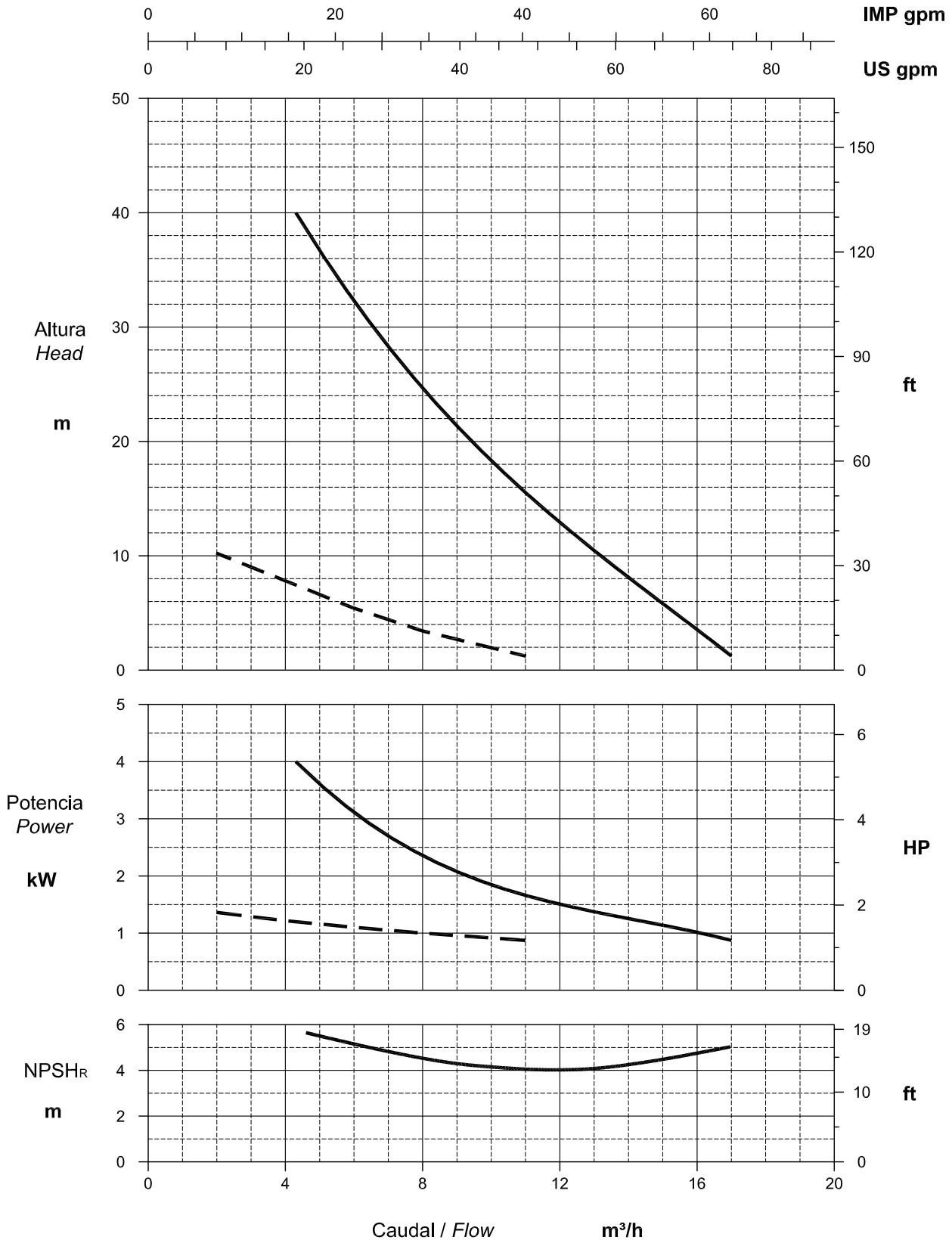

Los datos hacen referencia a agua limpia a 20°C / Performance data refer to clear water at 20°C

Tolerancia según ISO 9906:1999 Anexo A / Permissible tolerance ISO 9906:1999 Annex A



CURVAS CARACTERÍSTICAS  
PERFORMANCE CURVES

Rodete / Impeller Estrella / Star-shaped	Ø Boca asp. / Pump inlet DN-50	Bomba / Pump <b>A-150</b>
Ø Rodete / Ø Impeller 160 mm	Ø Boca imp. / Pump outlet DN-50	
Número palas / Number of blades 23	——— By-pass cerrado / closed - - - - By-pass abierto / opened	Velocidad / Speed 1450 rpm

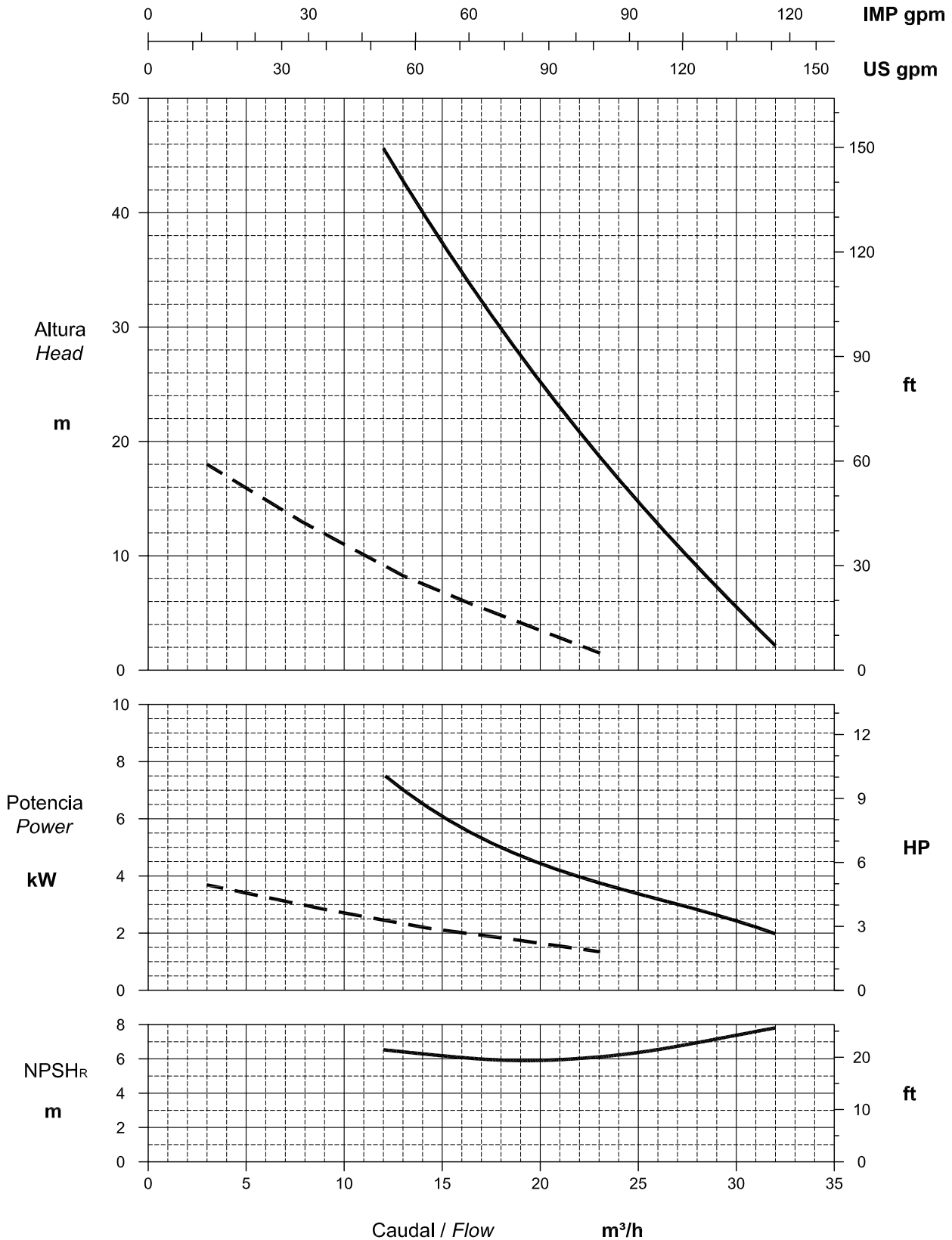

Los datos hacen referencia a agua limpia a 20°C / Performance data refer to clear water at 20°C

Tolerancia según ISO 9906:1999 Anexo A / Permissible tolerance ISO 9906:1999 Annex A





CURVAS CARACTERÍSTICAS  
PERFORMANCE CURVES

Rodete / Impeller Estrella / Star-shaped	Ø Boca asp. / Pump inlet DN-65	Bomba / Pump <b>A-200</b>
Ø Rodete / Ø Impeller 195 mm	Ø Boca imp. / Pump outlet DN-65	
Número palas / Number of blades 24	——— By-pass cerrado / closed - - - - By-pass abierto / opened	Velocidad / Speed 1450 rpm

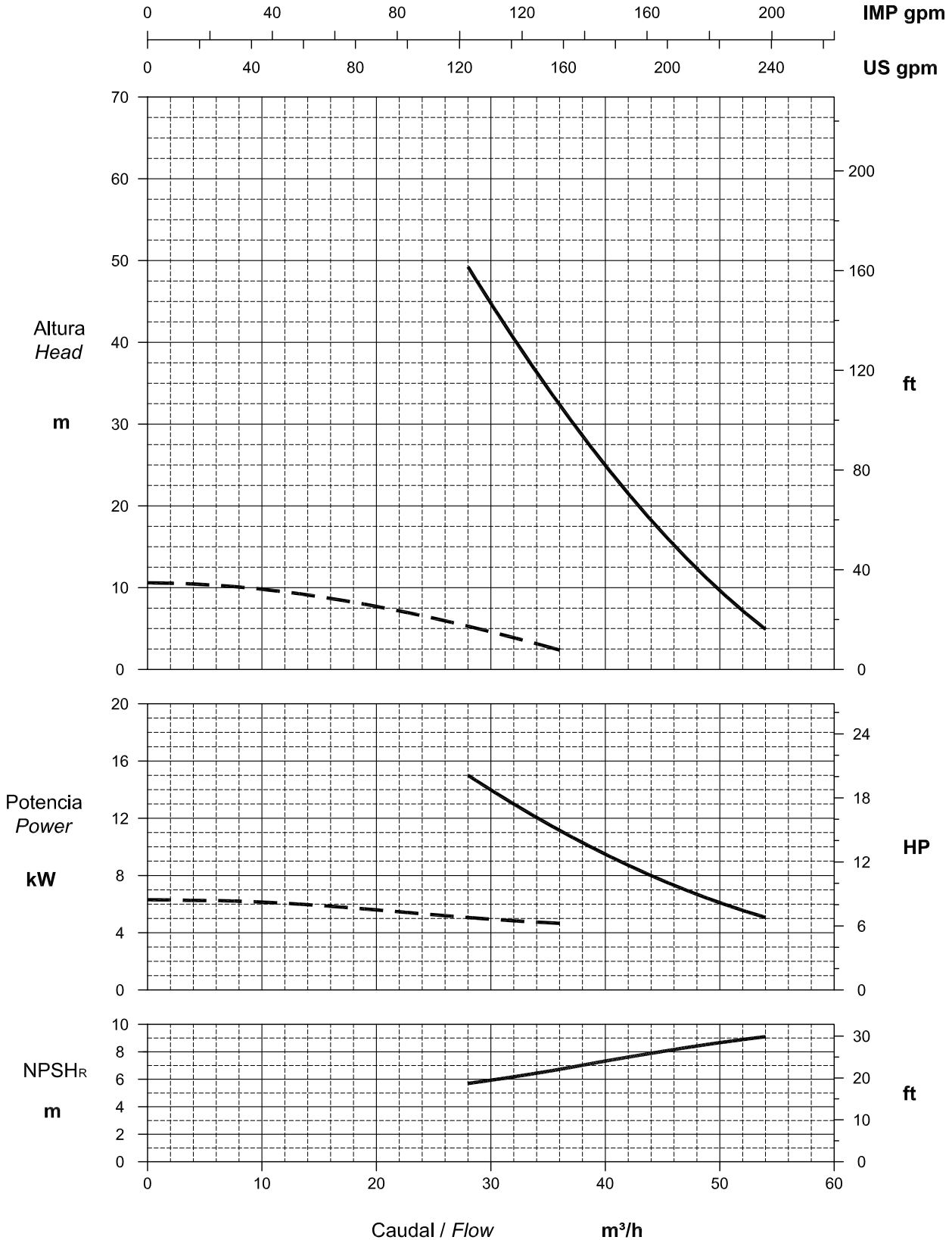

Los datos hacen referencia a agua limpia a 20°C / Performance data refer to clear water at 20°C

Tolerancia según ISO 9906:1999 Anexo A / Permissible tolerance ISO 9906:1999 Annex A





CURVAS CARACTERÍSTICAS  
PERFORMANCE CURVES

ÁREA DE SELECCIÓN  
PERFORMANCE CHART

Velocidad / Speed

1750 rpm (60 Hz)

Bomba / Pump

**ASPIR**

Rodete / Impeller

Estrella / Star-shaped

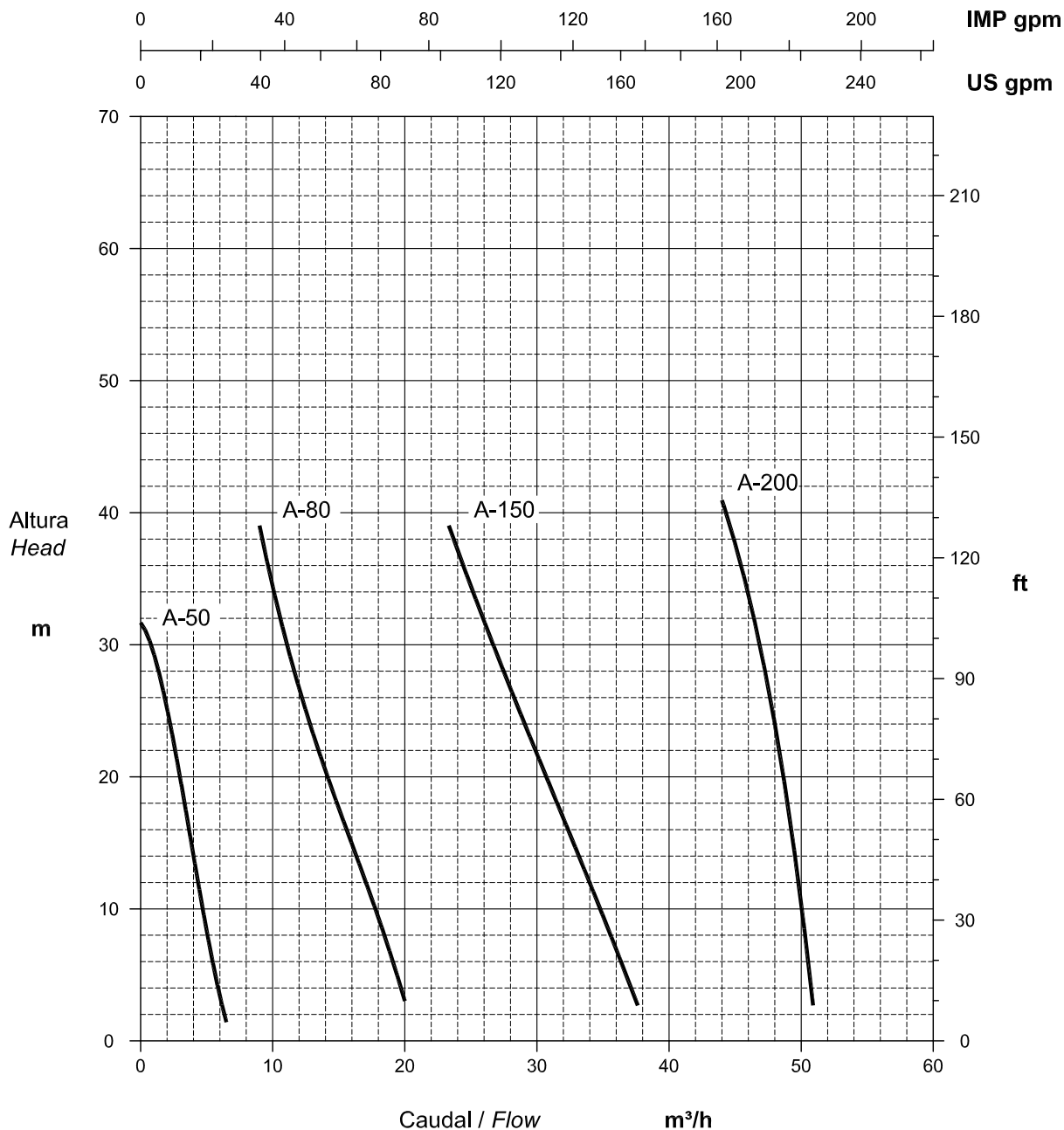

Los datos hacen referencia a agua limpia a 20°C / Performance data refer to clear water at 20°C

Tolerancia según ISO 9906:1999 Anexo A / Permissible tolerance ISO 9906:1999 Annex A



CURVAS CARACTERÍSTICAS  
PERFORMANCE CURVES

Rodete / Impeller Estrella / Star-shaped	Ø Boca asp. / Pump inlet DN-32	Bomba / Pump <b>A-50</b>
Ø Rodete / Ø Impeller 110 mm	Ø Boca imp. / Pump outlet DN-32	
Número palas / Number of blades 24	——— By-pass cerrado / closed - - - - By-pass abierto / opened	Velocidad / Speed 1700 rpm

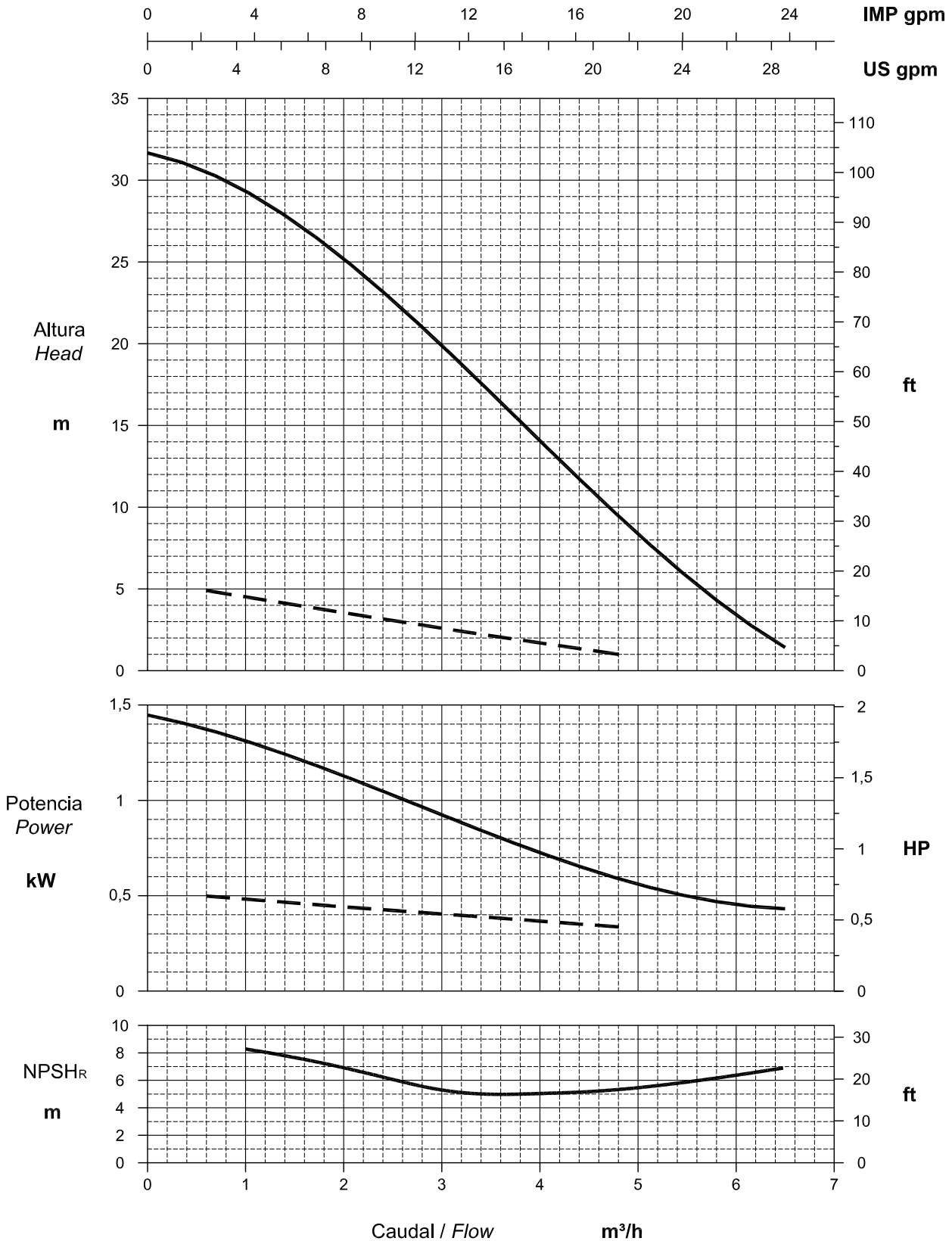

Los datos hacen referencia a agua limpia a 20°C / Performance data refer to clear water at 20°C

Tolerancia según ISO 9906:1999 Anexo A / Permissible tolerance ISO 9906:1999 Annex A



CURVAS CARACTERÍSTICAS  
PERFORMANCE CURVES

Rodete / Impeller Estrella / Star-shaped	Ø Boca asp. / Pump inlet DN-40	Bomba / Pump <b>A-80</b>
Ø Rodete / Ø Impeller 135 mm	Ø Boca imp. / Pump outlet DN-40	
Número palas / Number of blades 24	——— By-pass cerrado / closed - - - - By-pass abierto / opened	Velocidad / Speed 1750 rpm

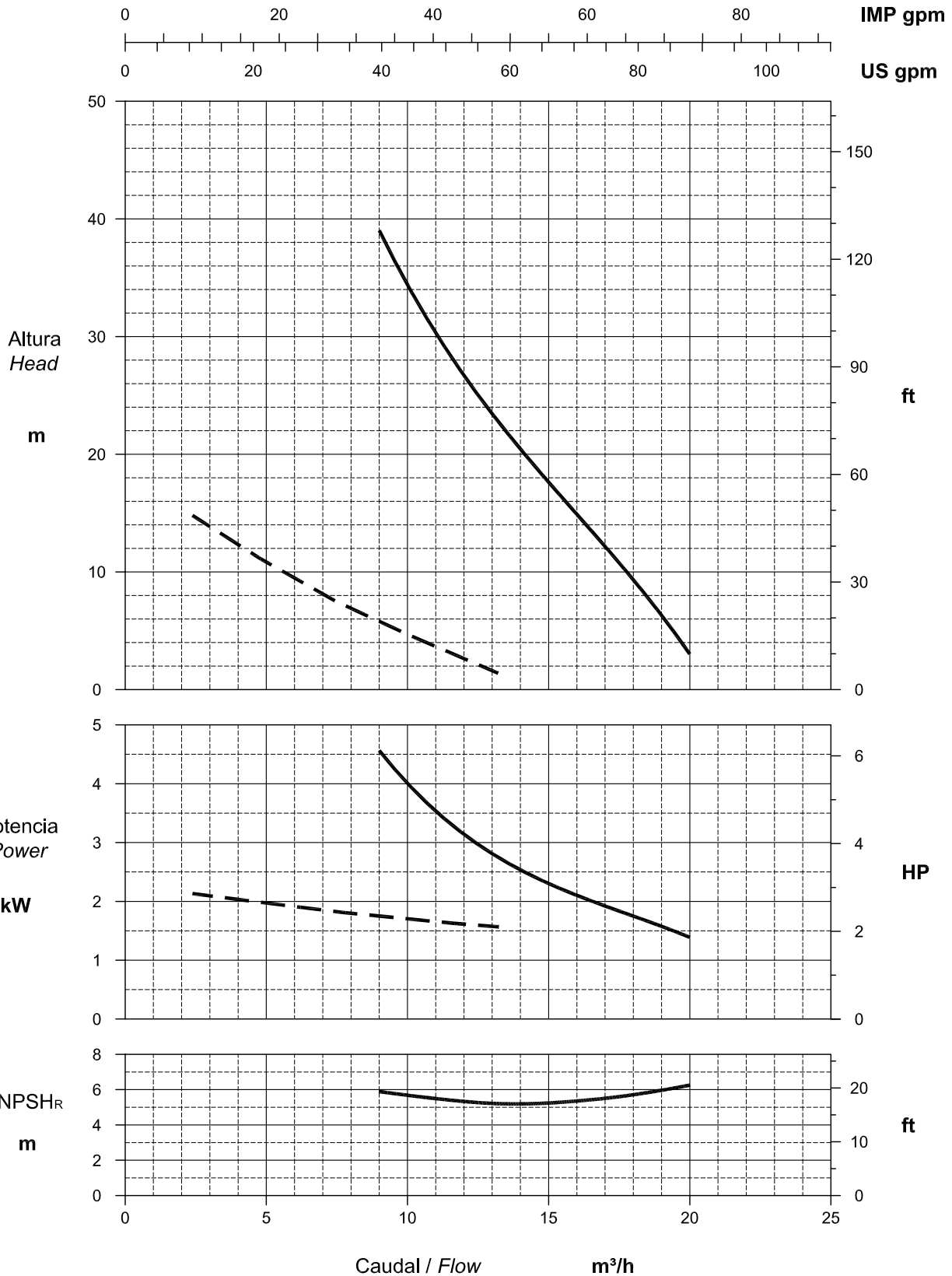

Los datos hacen referencia a agua limpia a 20°C / Performance data refer to clear water at 20°C

Tolerancia según ISO 9906:1999 Anexo A / Permissible tolerance ISO 9906:1999 Annex A



CURVAS CARACTERÍSTICAS  
PERFORMANCE CURVES

Rodete / Impeller Estrella / Star-shaped	Ø Boca asp. / Pump inlet DN-50	Bomba / Pump <b>A-150</b>
Ø Rodete / Ø Impeller 160 mm	Ø Boca imp. / Pump outlet DN-50	
Número palas / Number of blades 23	— By-pass cerrado / closed - - - By-pass abierto / opened	Velocidad / Speed 1750 rpm

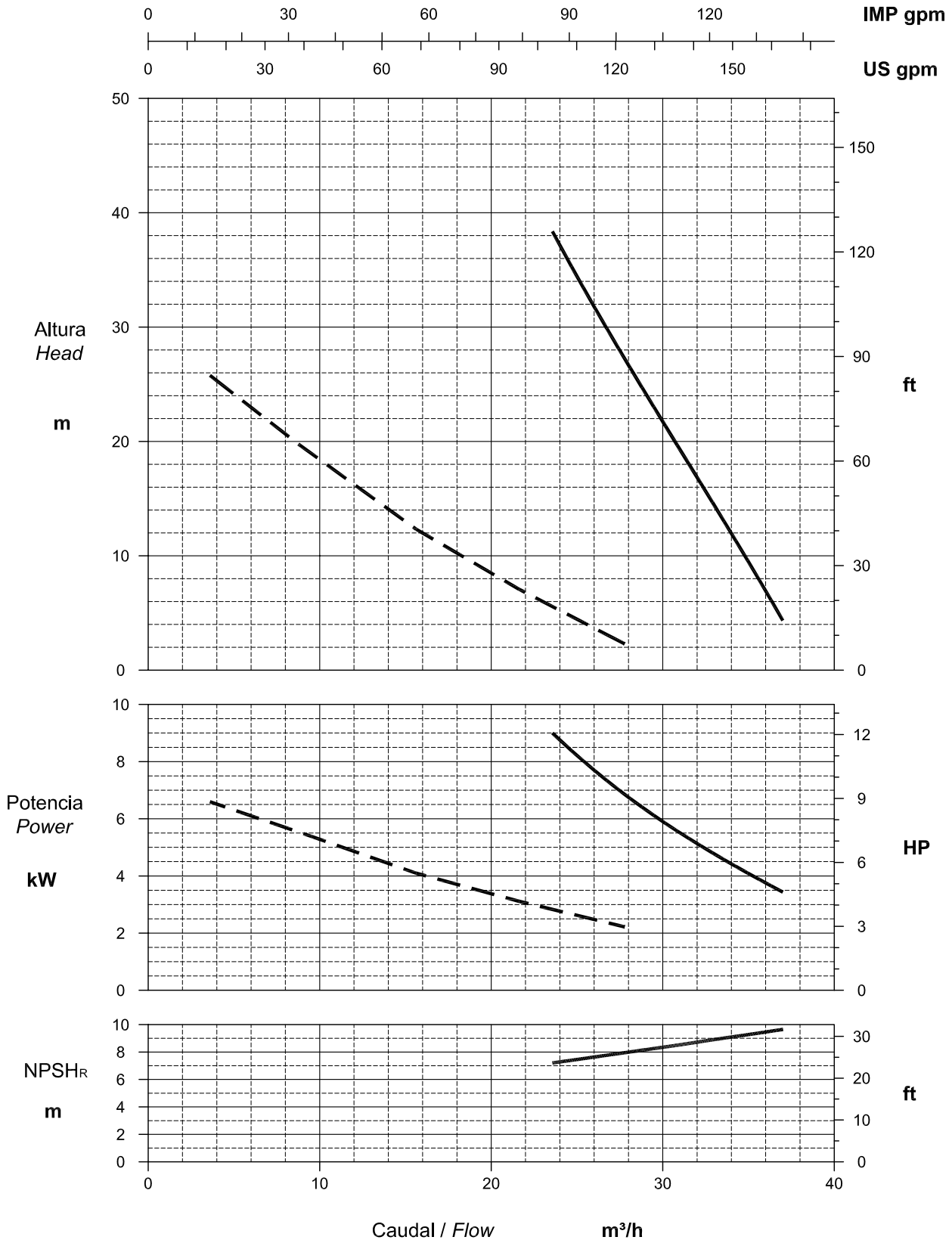

Los datos hacen referencia a agua limpia a 20°C / Performance data refer to clear water at 20°C

Tolerancia según ISO 9906:1999 Anexo A / Permissible tolerance ISO 9906:1999 Annex A



CURVAS CARACTERÍSTICAS  
PERFORMANCE CURVES

Rodete / Impeller Estrella / Star-shaped	Ø Boca asp. / Pump inlet DN-65	Bomba / Pump <b>A-200</b>
Ø Rodete / Ø Impeller 195 mm	Ø Boca imp. / Pump outlet DN-65	
Número palas / Number of blades 24	——— By-pass cerrado / closed - - - - By-pass abierto / opened	Velocidad / Speed 1750 rpm

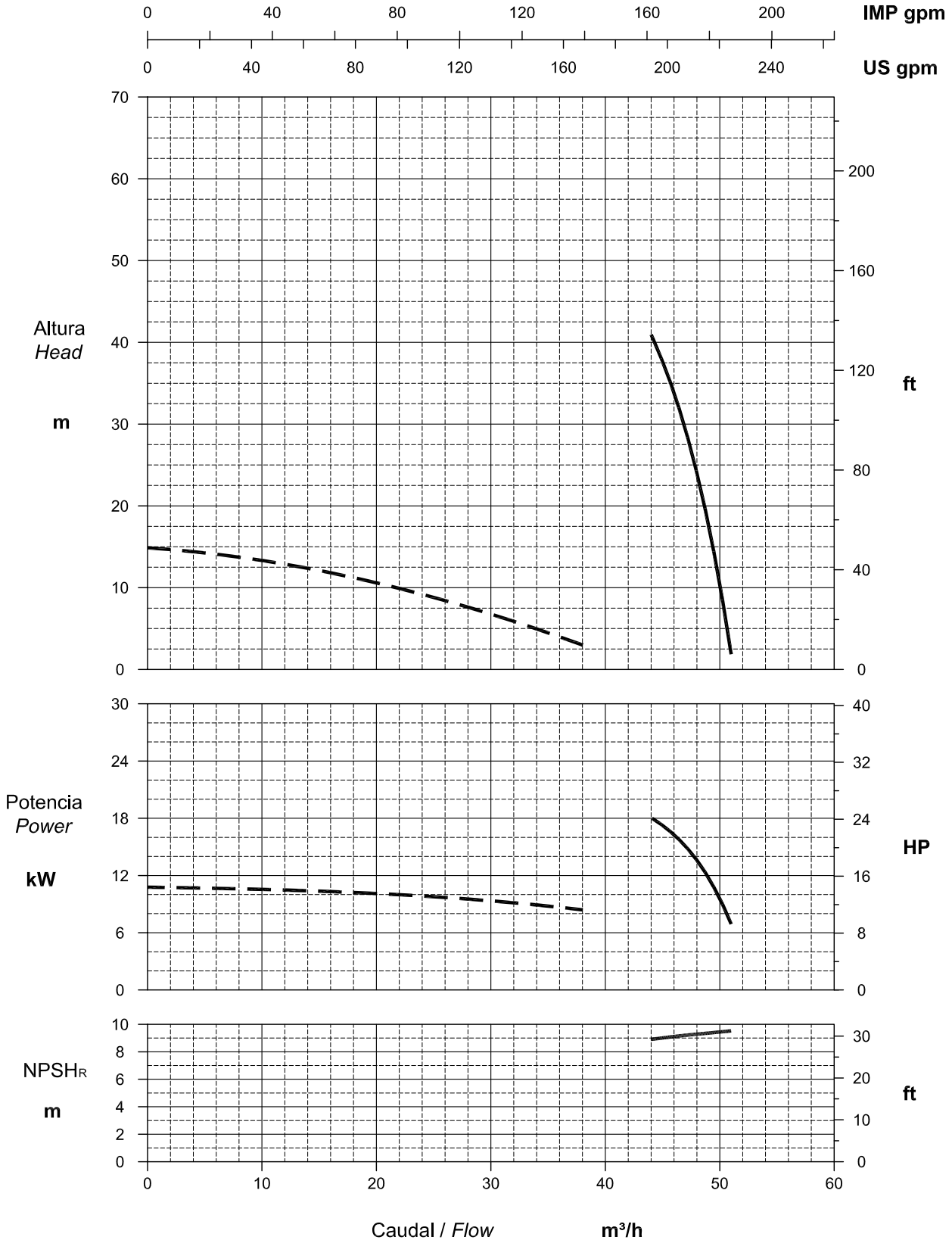

Los datos hacen referencia a agua limpia a 20°C / Performance data refer to clear water at 20°C

Tolerancia según ISO 9906:1999 Anexo A / Permissible tolerance ISO 9906:1999 Annex A

NOTAS / NOTES

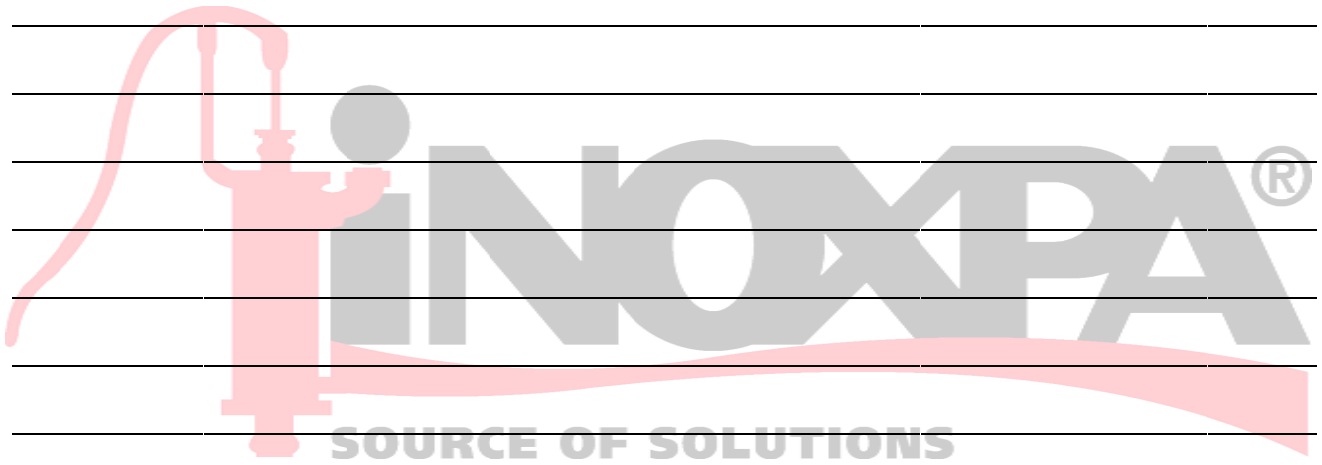





NOTAS / NOTES

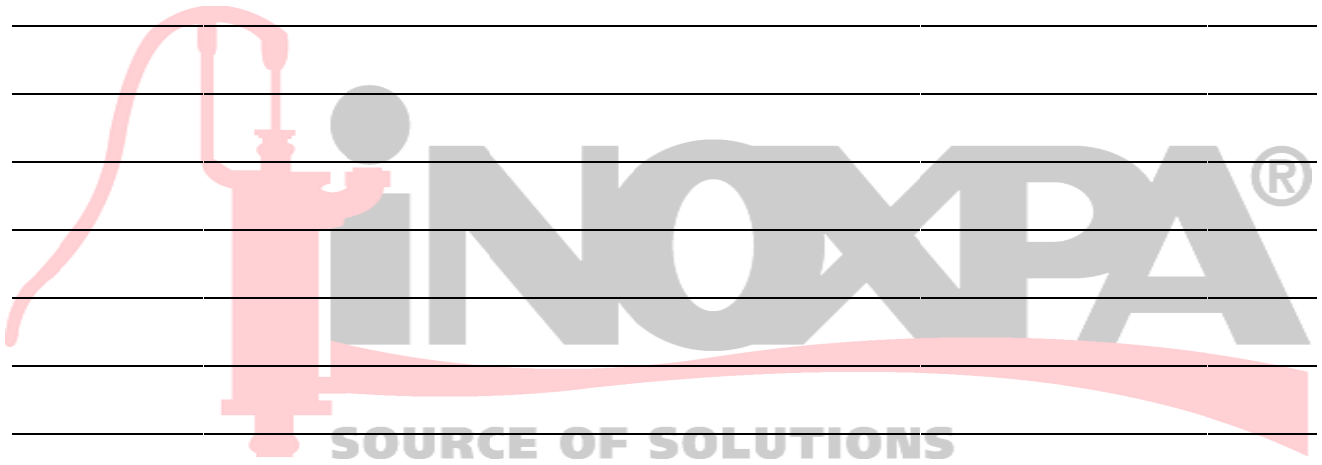



**INOXPA, S.A.**

c/ Telers, 54 – PO Box 174  
17820 BANYOLES (GIRONA)  
Tel: 34 972575200  
Fax: 34 972575520  
e-mail: inoxpa@inoxpa.com  
www.inoxpa.com

**DELEGACIÓN LEVANTE**

PATERNA (VALENCIA)  
Tel: 963 170 101  
Fax: 963 777 539  
e-mail: inoxpa.levante@inoxpa.com

**DELEGACIÓN STA**

GALDACANO (BILBAO)  
Tel: 944 572 058  
Fax: 944 571 806  
e-mail: sta@inoxpa.com

**DELEGACIÓN LA RIOJA**

LOGROÑO  
Tel: 941 228 622  
Fax: 941 204 290  
e-mail: sta.rioja@inoxpa.com

**INOXPA ALGERIE**

ROUIBA  
Tel: 213 21856363/21851780  
Fax: 213 21854431  
e-mail: inoxpalgerie@inoxpa.com

**INOXPA FRANCE, S.A.**

GLEIZE  
Tel: 33 474627100  
Fax: 33 474627101  
e-mail: inoxpa.fr@inoxpa.com

**INOXPA SOLUTIONS FRANCE**

CHAMBLY (PARIS)  
Tel: 33 130289100  
Fax: 33 130289101  
e-mail: isf@inoxpa.com

**INOXPA SKANDINAVIEN A/S**

HORSENS (DENMARK)  
Tel: 45 76286900  
Fax: 45 76286909  
e-mail: inoxpa.dk@inoxpa.com

**S.T.A. PORTUGUESA LDA**

VALE DE CAMBRA  
Tel: 351 256472722  
Fax: 351 256425697  
e-mail: comercial.pt@inoxpa.com

**INOXPA POLAND SP Z.O.O.**

GDANSK  
Tel: 48 585110005  
Fax: 48 585567251  
e-mail: inoxpa.pl@inoxpa.com

**INOXRUS – SAINT  
PETERSBURG**

Tel: 78126221626  
Fax: 78126221926  
e-mail: spb@inoxpa.com

**DELEGACIÓN NORD-ESTE**

BARBERÀ DEL VALLÈS (BCN)  
Tel: 937 297 280  
Fax: 937 296 220  
e-mail: inoxpa.nordeste@inoxpa.com

**DELEGACIÓN CENTRO**

ARGANDA DEL REY (MADRID)  
Tel: 918 716 084  
Fax: 918 703 641  
e-mail: inoxpa.centro@inoxpa.com

**DELEGACIÓN VALLADOLID**

LA CISTÉRNIGA (VALLADOLID)  
Tel: 983 403 197  
Fax: 983 402 640  
e-mail: sta.valladolid@inoxpa.com

**DELEGACIÓN SUR**

SEVILLA  
Tel: 954 296 852  
Fax: 954 296 022  
e-mail: inoxpa.sur@inoxpa.com

**INOXPA SOUTH AFRICA (PTY) LTD**

JOHANNESBURG  
Tel: 011 7965170  
Fax: 086 6807756  
e-mail: sales@inoxpa.com

**AGENCE OUEST**

BASSE GOULAINÉ  
Tel: 33 228010172  
Fax: 33 228010173  
e-mail: inoxpa.fr@inoxpa.com

**INOXPA USA, Inc**

SANTA ROSA  
Tel: 1 7075853900  
Fax: 1 7075853908  
e-mail: inoxpa.us@inoxpa.com

**INOXPA SKANDINAVIEN A/S**

PARTILLE (SWEDEN)  
Tel: 46 313360560  
Fax: 46 313360561  
e-mail: inoxpa.se@inoxpa.com

**IMPROVED SOLUTIONS PORTUGAL**

VALE DE CAMBRA  
Tel: 351 256472138  
Fax: 351 256472130  
e-mail: isp.pt@inoxpa.com

**BOMBAS IMCHISA, S.A.**

SANTIAGO DE CHILE  
Tel: 5627266945/6  
e-mail: info@inoxpa.cl

**INOXPA SPECIAL PROCESSING  
EQUIPMENT, CO., LTD.**

JIA XING (China)  
Tel.: 00 86 573 83570035  
Fax: 00 86 573 83570038

**DELEGACIÓN ARAGÓN**

ZARAGOZA  
Tel: 976 591 942  
Fax: 976 591 473  
e-mail:

**DELEGACIÓN CENTRO**

TOMELLOSO (CIUDAD REAL)  
Tel: 926 514 190  
Fax: 926 513 897  
e-mail: inoxpa.centro@inoxpa.com

**DELEGACIÓN ASTURIAS**

LUGONES (OVIEDO)  
Tel: 944 572 058  
Fax: 944 572 058  
e-mail: sta.asturias@inoxpa.com

**DELEGACIÓN SUR**

JEREZ DE LA FRONTERA (CÁDIZ)  
Tel / Fax: 956 140 193  
e-mail: inoxpa.sur@inoxpa.com

**INOXPA AUSTRALIA PTY**

VIRGINIA (QUEENSLAND)  
Tel: 61 732567788  
Fax: 61 732568889  
e-mail: inoxpa.au@inoxpa.com

**AGENCE NORD-BENELUX**

WAMBRECHIES  
Tel: 33 320631000  
Fax: 33 320631001  
e-mail:

**INOXPA ITALIA, S.R.L.**

VAIANO CREMASCO  
Tel: 39 373791076  
Fax: 39 373791113  
e-mail: inoxpa.it@inoxpa.com

**INOXPA UK LTD**

SURREY  
Tel: 1737378060  
Fax: 1737766539  
e-mail: inoxpa-uk@inoxpa.com

**INOXPA DEUTSCHLAND**

LEINFELDEN  
Tel: 49 7117585973  
Fax: 49 71175859750  
e-mail: inoxpa.de@inoxpa.com

**INOXRUS – MOSCOW**

Tel / Fax: 7 4955441839  
e-mail: moscow@inoxpa.com

**INOXPA INDIA PVT. LTD.**

Maharashtra, INDIA.  
inoxpa.in@inoxpa.com