

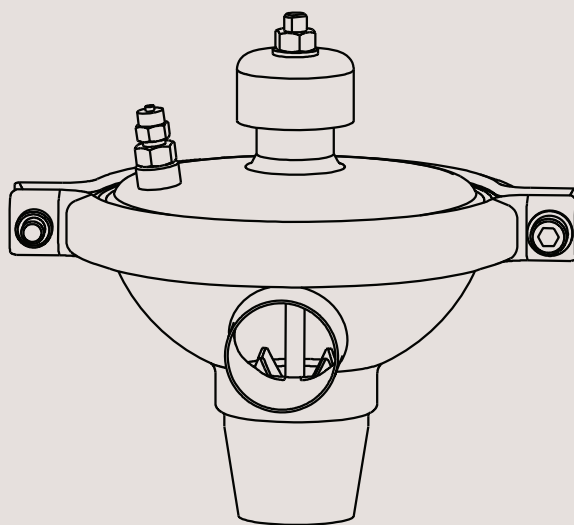

Instruction Manual

CPM-2 Constant-Pressure Modulating Valve



TD 417-121

ESE01825-EN7 2015-4

Original manual



The information herein is correct at the time of issue but may be subject to change without prior notice

1. EC Declaration of Conformity	4
2. Safety	5
2.1. Important information	5
2.2. Warning signs	5
2.3. Safety precautions	6
3. Installation	7
3.1. Unpacking/delivery	7
3.2. General installation	7
3.3. Welding	9
3.4. Fitting of booster (optional extra)	10
3.5. Recycling information	12
4. Operation	13
4.1. Operation	13
4.2. Fault finding	15
4.3. Recommended cleaning	16
5. Maintenance	18
5.1. General maintenance	18
5.2. Dismantling	19
5.3. Assembly	21
6. Technical data	24
6.1. Technical data	24
6.2. Selection / pressure drop - capacity diagram	25
7. Parts lists and service kit	27
7.1. CPM-2	27
7.2. Booster	31

1 EC Declaration of Conformity

Revision of Declaration of Conformity 2009-12-29

The Designated Company

Alfa Laval Kolding A/S

Company Name

Albuen 31, DK-6000 Kolding, Denmark

Address

+45 79 32 22 00

Phone No.

hereby declare that

Valve

Designation

CPM-2

Type

is in conformity with the following directive with amendments:

- Machinery Directive 2006/42/EC
- Regulation (EC) No 1935/2004

The person authorised to compile the technical file is the signer of this document

QHSE Manager, Quality, Health and safety & Environment

Title

Annie Dahl

Name

Kolding

Place

2013-12-03

Date



Signature



Unsafe practices and other important information are emphasized in this manual.

Warnings are emphasized by means of special signs.

All warnings in the manual are summarized on this page.

Pay special attention to the instructions below so that severe personal injury or damage to the valve are avoided.

2.1 Important information

Always read the manual before using the valve!

WARNING

Indicates that special procedures must be followed to avoid severe personal injury.

CAUTION

Indicates that special procedures must be followed to avoid damage to the valve.

NOTE

Indicates important information to simplify or clarify procedures.

2.2 Warning signs

General warning:



Caustic agents:



2 Safety

Unsafe practices and other important information are emphasized in this manual.

Warnings are emphasized by means of special signs.

All warnings in the manual are summarized on this page.

Pay special attention to the instructions below so that severe personal injury or damage to the valve are avoided.

2.3 Safety precautions

Installation

Always read the technical data thoroughly (See chapter 6 Technical data)

Always release compressed air after use.

Never touch the valve top if compressed air is supplied to the valve.

The valve and the pipelines **must** never be pressurised when dismantling the valve.



Operation

Always read the technical data thoroughly (See chapter 6 Technical data).

Always release compressed air after use.

Never touch the valve or the pipelines when processing hot liquids or when sterilizing.

Never touch the valve top if compressed air is supplied to the valve.



Always handle lye and acid with great care.



Maintenance

Always observe the technical data thoroughly (See chapter 6 Technical data).

Always release compressed air after use.

Never service the valve when it is hot.

Never service the valve with valve and pipelines under pressure.



Transportation

Always secure that compressed air is released .

Always secure that all connections is disconnected before attempt to remove the valve from the installation.

Always drain liquid out of valves before transportation.

Always used predesigned lifting points if defined.

Always secure sufficient fixing of the valve during transportation - if special designed packaging material is available it must be used.

The instruction manual is part of the delivery.
 Study the instructions carefully.
 CPMI-2: Constant-Pressure Modulating Inlet.
 CPMO-2: Constant-Pressure Modulating Outlet.

3.1 Unpacking/delivery

Step 1

CAUTION

Alfa Laval cannot be held responsible for incorrect unpacking.

Check the delivery:

1. Complete valve, CPMI-2 or CPMO-2.
2. Delivery note.
3. Instruction manual.

Step 2

Remove possible packing materials from the valve ports.
 Avoid damaging the air connection and the valve ports.

Remove packing materials!

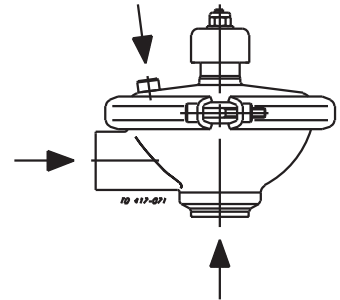

Step 3

1. Inspect the valve for visible transport damage.

Inspection!

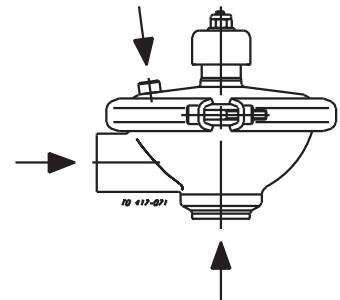

3.2 General installation

Step 1



Always read the technical data thoroughly.



Always release compressed air after use.

Never touch the valve top if compressed air is supplied to the valve.

CAUTION

Alfa Laval cannot be held responsible for incorrect installation.

Step 2

Ensure that the flow direction is correct.

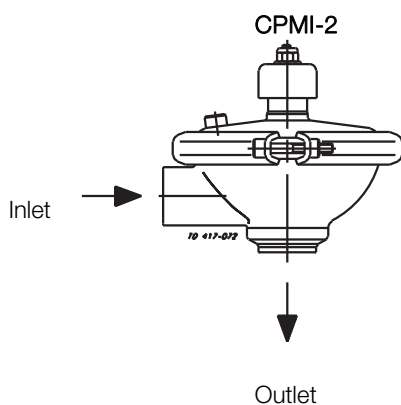

Correct

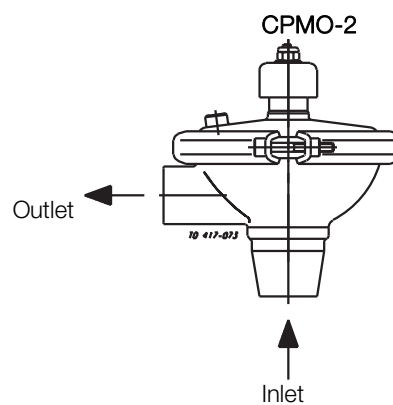

3 Installation

Study the instructions carefully and pay special attention to the warnings!

The valve has welding ends as standard but can also be supplied with fittings.

CPMI-2: Constant-Pressure Modulating Inlet. CPMO-2: Constant-Pressure Modulating Outlet.

The required product pressure is preset by means of an air pressure regulating valve (optional extra).

Step 3

Avoid stressing the valve.

Pay special attention to:

- Vibrations.
- Thermal expansion of the tubes.
- Excessive welding.
- Overloading of the pipelines.

Risk of damage!

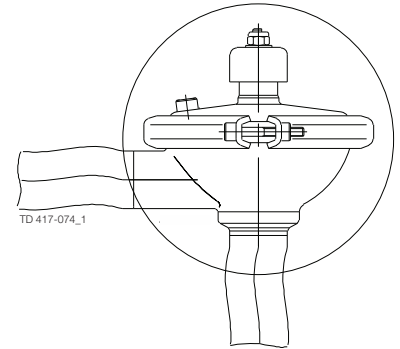

Step 4

Fittings:

Ensure that the connections are tight.

Remember seal rings!

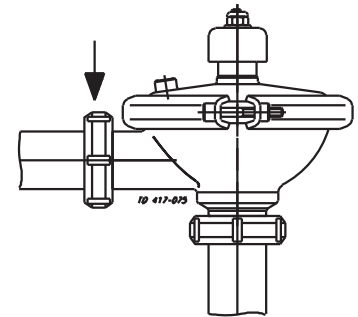

Step 5

Air connection:

R1/4 " (BSP)

Air

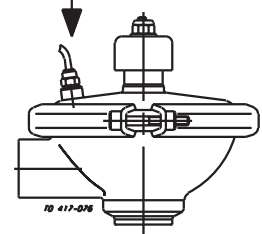

Step 6

Air pressure regulating valve (optional extra):

An air pressure regulating valve must be used and should be installed with min. clearance to the Booster/CPM-2 valve.

Pressure regulating valve

As close as possible!

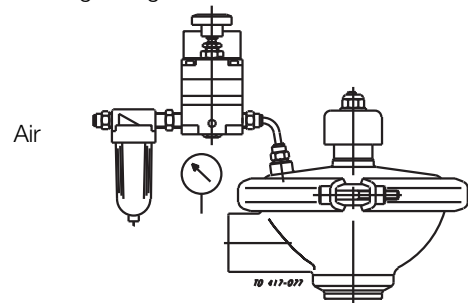

Study the instructions carefully.

The valve has welding ends as standard. Weld carefully.

CPMI-2: Constant-Pressure Modulating Inlet.

CPMO-2: Constant-Pressure Modulating Outlet.

3.3 Welding

Step 1

Dismantle the valve in accordance with Step 1 - Step 4 in chapter 5.2 Dismantling.

Pay special attention to the warning!

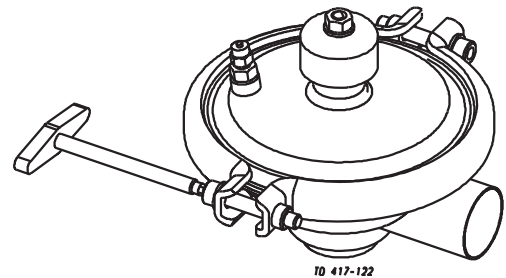

Step 2

CPMI-2:

1. Weld the valve body into the pipelines.
2. Maintain the minimum clearance so that the internal valve parts can be removed.

A = 200 mm (without booster) / 250 mm (with booster)

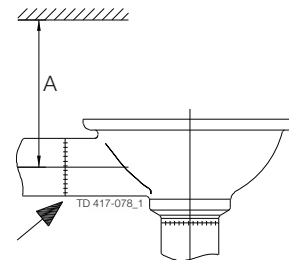

Step 3

CPMO-2:

1. Weld the valve body into the pipelines (see also Step 4).
2. Maintain the minimum clearance so that the valve plug can be removed.

A = 150 mm (without booster) / 200 mm (with booster)

B = 250 mm

Caution!

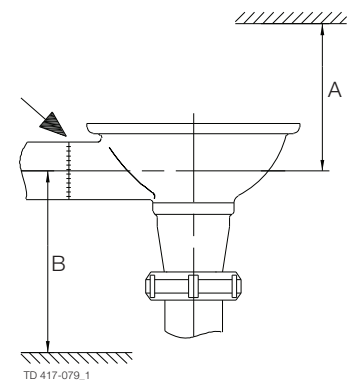

Step 4

CPMO-2:

Never weld the bottom connection as this will make it impossible to dismantle the valve.

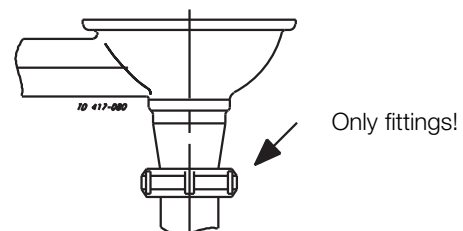

Step 5

Assemble the valve in accordance with Step 6 - Step 10 in chapter 5.3 Assembly.

Tighten clamp 10-15 Nm (7.5-11 lbf-ft)

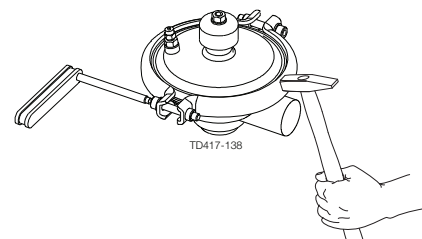

3 Installation

Study the instructions carefully and pay special attention to the warnings!

The items refer to the parts list and service kits section.

The valve can be fitted with a Booster to allow for a product pressure higher than available air pressure.

Step 6

Pre-use check:

Lift and lower the valve top several times to ensure that the valve operates smoothly.

Pay special attention to the warning!

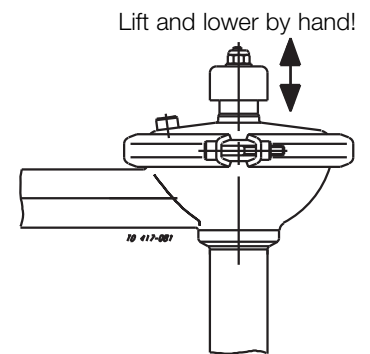

3.4 Fitting of booster (optional extra)

Step 1



Never touch the valve or the pipelines when processing hot liquids or when sterilising.

The valve and the pipelines must **never** be pressurised when dismantling the valve.

Atmospheric pressure required!

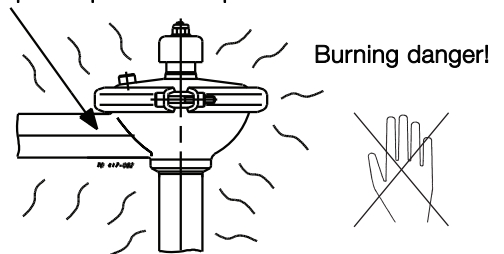

Step 2

1. Remove the valve top in accordance with Step 3 in chapter 5.2 Dismantling

Pay special attention to the warnings!

2. Fit Booster housing (1) on the cover.
3. Fit and tighten lock nut (2).

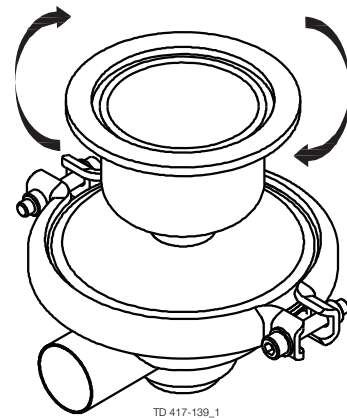

Step 3

1. Fit washer (3).
2. Refit the washer and the top nut on the valve plug.

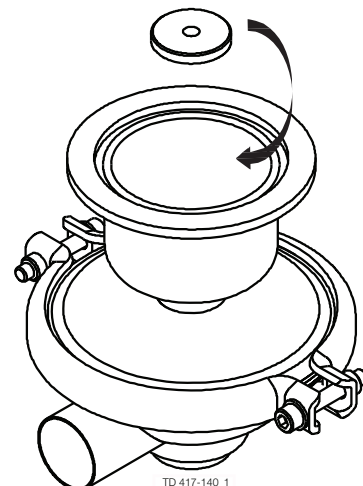

3 Installation

Study the instructions carefully and pay special attention to the warnings!

The items refer to the parts list and service kits section.

The valve can be fitted with a Booster to allow for a product pressure higher than available air pressure.

Step 4

1. Turn diaphragm (7) inside out.
2. Place piston (6) in the diaphragm so that the hole is visible.

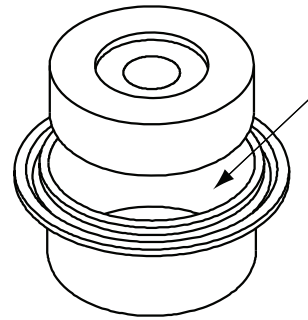

Step 5

1. Roll diaphragm (7) down half its length.
2. Fit the diaphragm with piston (6) in Booster housing (1).

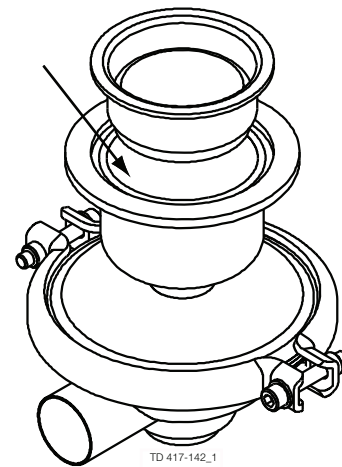

Step 6

1. Fit cover (8) on Booster housing (1).
2. Fit and tighten clamp (9).
3. The valve and the Booster are now ready for operation.

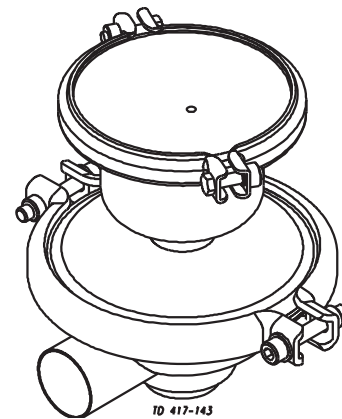

3 Installation

Study the instructions carefully and pay special attention to the warnings!

The items refer to the parts list and service kits section.

The valve can be fitted with a Booster to allow for a product pressure higher than available air pressure.

Step 7

Compressed air:

An air pressure compensating regulating valve must be used and should be installed with min. clearance to the Booster/CPM-2 valve.

The pressure regulating valve (PR) and the pressure gauge (PG) are optional extras.

Alfa Laval recommends using the air pressure regulating valve from Alfa Laval.

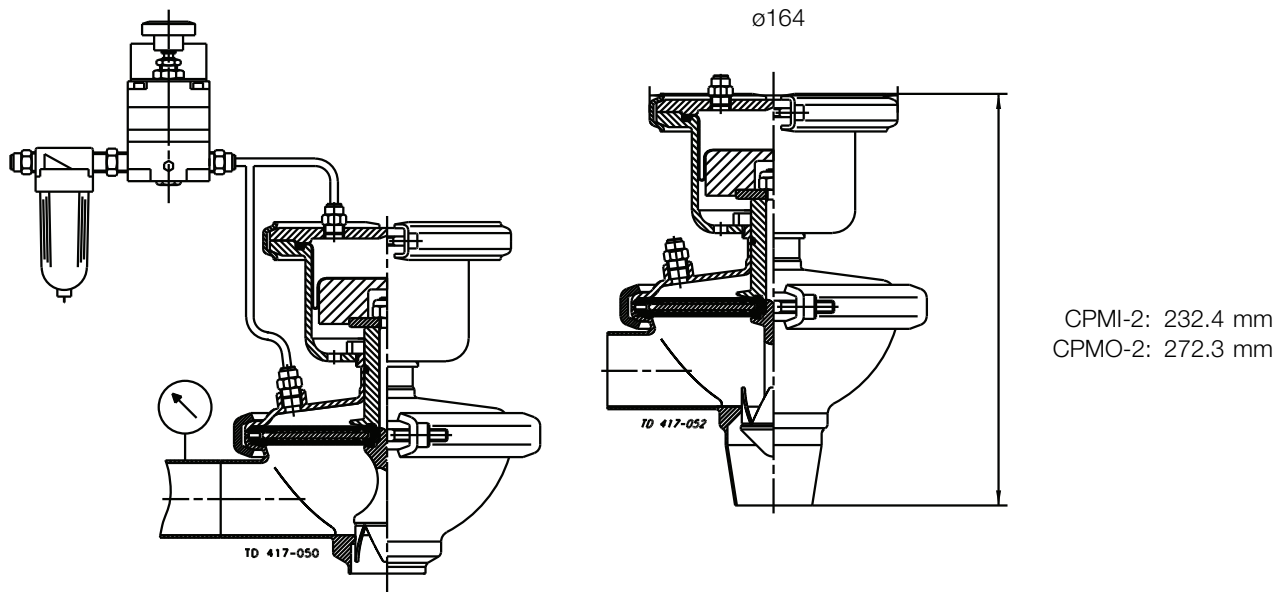

3.5 Recycling information

• Unpacking

- Packing material consists of wood, plastics, cardboard boxes and in some cases metal straps
- Wood and cardboard boxes can be reused, recycled or used for energy recovery
- Plastics should be recycled or burnt at a licensed waste incineration plant
- Metal straps should be sent for material recycling

• Maintenance

- During maintenance oil and wear parts in the machine are replaced
- All metal parts should be sent for material recycling
- Worn out or defective electronic parts should be sent to a licensed handler for material recycling
- Oil and all non metal wear parts must be taken care of in agreement with local regulations

• Scrapping

- At end of use, the equipment shall be recycled according to relevant, local regulations. Beside the equipment itself, any hazardous residues from the process liquid must be considered and dealt with in a proper manner. When in doubt, or in the absence of local regulations, please contact the local Alfa Laval sales company

The valve is lubricated, adjusted and tested before delivery.
Study the instructions carefully and pay special attention to the warnings!
The items refer to the parts list and service kits section.

4.1 Operation

Step 1



Always read the technical data thoroughly.



Always release compressed air after use.

CAUTION

Alfa Laval cannot be held responsible for incorrect operation.

Step 2



Never touch the valve or the pipelines when processing hot liquids or when sterilizing.

Burning danger!

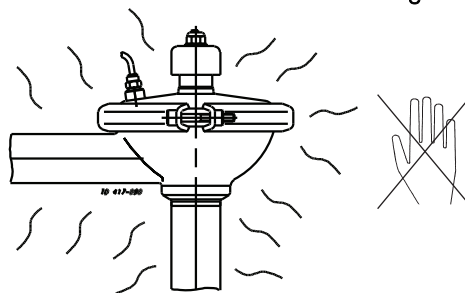

Step 3



Never touch the valve top if compressed air is supplied to the valve.

Cutting danger!

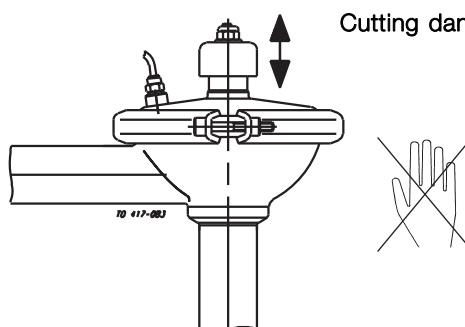

Step 4

CAUTION!

There must not be vacuum in the valve as air can be drawn into the product and diaphragms (14) can then be pulled out from support sectors (12).

No vacuum!

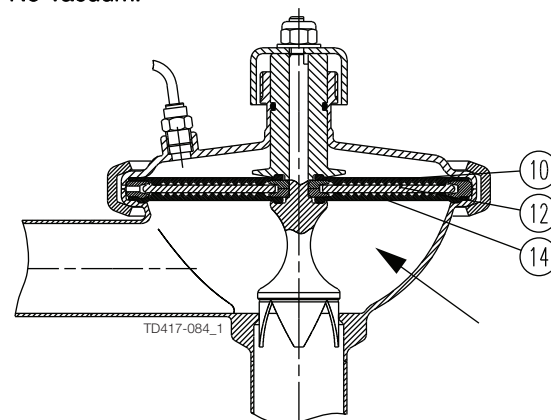

4 Operation

*The valve is lubricated, adjusted and tested before delivery.
Study the instructions carefully and pay special attention to the warnings!
The items refer to the parts list and service kits section.*

Step 5

Lubrication:

1. Ensure smooth movement between diaphragms (10,14) and support sectors (12).
2. Ensure smooth movement of guide (9).

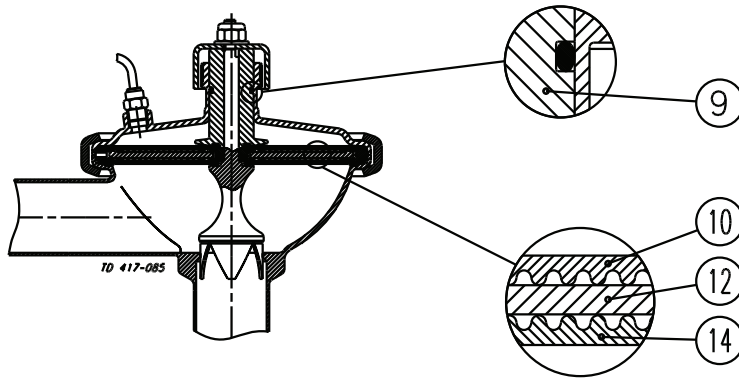

Lubricate if necessary!
(see chapter 5.1 General maintenance)

*Pay attention to possible break-down.
Study the instructions carefully.
The items refer to the parts list and service kits section.*

4.2 Fault finding

NOTE!

Study the maintenance instructions carefully before replacing worn parts - see chapter 5 Maintenance

Problem	Cause/result	Repair
The valve does not maintain the preset pressure	Faulty diaphragm	Replace the diaphragm
	Guide (9) seizes	Lubricate the guide (see section 3.1)
	Incorrect operating range	Check the pressure drop over the valve and check the flow rate (see chapter 6.2 Selection / pressure drop - capacity diagram)
	The available air pressure is lower than the product pressure	Increase the air pressure eg. by using a Booster (see chapter 3.4 Fitting of booster (optional extra)).
	The air pressure is not correctly adjusted	Readjust the air pressure
	Faulty air pressure regulating valve or incorrect type	Repair the valve or check that it is pressure compensating
Product leakage	Worn diaphragm Product affected diaphragm	Replace the diaphragm
Air leakage	Worn O-ring	Replace the O-ring
	Worn diaphragm (10)	Replace the diaphragm
	Worn and hard diaphragm (10)	Replace by a diaphragm of a different grade for higher temperature (see chapter 6.1 Technical data)
Valve plug moving too fast up and down (unstable)	Pressure pulsations because of fast changes in process conditions	Use an air throttling valve (optional extra between the air pressure regulating valve and the CPM-2 valve.

4 Operation

The valve is designed for cleaning in place (CIP).

CIP = Cleaning In Place.

Study the instructions carefully and pay special attention to the warnings!

NaOH = Caustic Soda. HNO₃ = Nitric acid.

4.3 Recommended cleaning

Step 1



Always handle lye and acid with great care.

Caustic danger!



Always use rubber gloves!



Always use protective goggles!

Step 2



Never touch the valve or the pipelines when sterilizing.

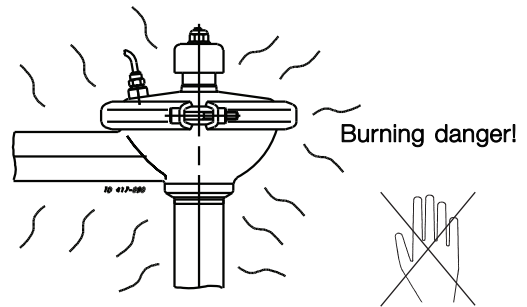

Step 3

CPMI-2

Ensure that the valve is fully open to allow for maximum CIP flow.

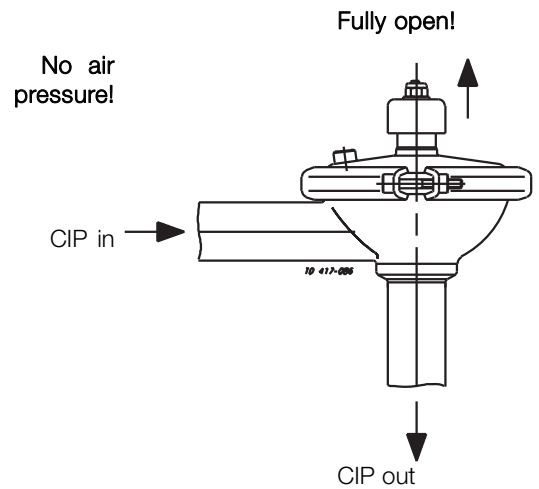

Step 4

CPMO-2

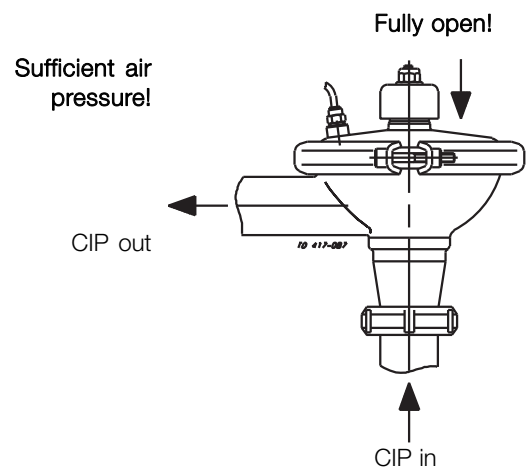

The valve is designed for cleaning in place (CIP).

CIP = Cleaning In Place.

Study the instructions carefully and pay special attention to the warnings!

NaOH = Caustic Soda. HNO₃ = Nitric acid.

Step 5

Examples of cleaning agents:

Use clean water, free from chlorides.

1. 1% by weight NaOH at 70° C (158° F)

$$\begin{array}{|c|} \hline 1 \text{ kg (2.2 lbs)} \\ \hline \text{NaOH} \\ \hline \end{array} + \begin{array}{|c|} \hline 100 \text{ l} \\ \hline (26.4 \text{ gal}) \text{ water} \\ \hline \end{array} = \text{Cleaning agent.}$$

2. 0.5% by weight HNO₃ at 70° C (158° F)

$$\begin{array}{|c|} \hline 0.7 \text{ l (0.2 gal)} \\ \hline 53\% \text{ HNO}_3 \\ \hline \end{array} + \begin{array}{|c|} \hline 100 \text{ l} \\ \hline (26.4 \text{ gal}) \text{ water} \\ \hline \end{array} = \text{Cleaning agent.}$$

$$\begin{array}{|c|} \hline 2.2 \text{ l (0.6 gal)} \\ \hline 33\% \text{ NaOH} \\ \hline \end{array} + \begin{array}{|c|} \hline 100 \text{ l} \\ \hline (26.4 \text{ gal}) \text{ water} \\ \hline \end{array} = \text{Cleaning agent.}$$

Step 6

1. Avoid excessive concentration of the cleaning agent.
 - **Dose gradually.**
2. Adjust the cleaning flow to the process.
 - **Sterilization of milk/viscous liquids.**
 - **Increase the cleaning flow.**
3. **Always** rinse well with clean water after the cleaning.

NOTE

The cleaning agents must be stored/disposed of in accordance with current rules/directives.

5 Maintenance

Maintain the valve carefully.
Study the instructions carefully and pay special attention to the warnings!
Always keep spare diaphragms and o-rings in stock.

5.1 General maintenance

Step 1



Always read the technical data thoroughly.
(See chapter 6.1 Technical data)



Always disconnect the compressed air before service.

NOTE

All scrap must be stored/discharged in accordance with current rules/directives.

Step 2



Never service the valve when it is hot.



Never service the valve with valve and pipelines under pressure.

Atmospheric pressure required!

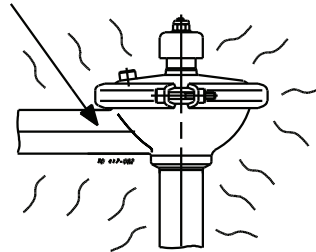

Burning danger!

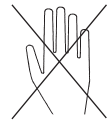

Recommended spare parts: Service kits (see 7 Parts lists and service kit).
Order service kits from the service kits list (see 7 Parts lists and service kit)

Ordering spare parts

Contact the Sales Department.

	Diaphragms	O-ring
Preventive maintenance	Replace after 12 months	Replace when replacing the diaphragms
Maintenance after leakage (leakage normally starts slowly)	Replace by the end of the day	Replace when replacing the diaphragms
Planned maintenance	<ul style="list-style-type: none"> - Regular inspection for leakage and smooth operation - Keep a record of the valve - Use the statistics for planning of inspections 	Replace when replacing diaphragms
	Replace after leakage	

Lubrication (before assembly)

Guide: Molycote longtherm 2 Plus
Sectors: Molycote 111.
Threads: Molycote TP42.

Study the instructions carefully.

The items refer to the parts list and service kits section.

Handle scrap correctly.

CPMI-2: Constant-Pressure Modulating Inlet. CPMO-2: Constant-Pressure Modulating Outlet.

5.2 Dismantling

Step 1

Loosen and remove clamp (6).

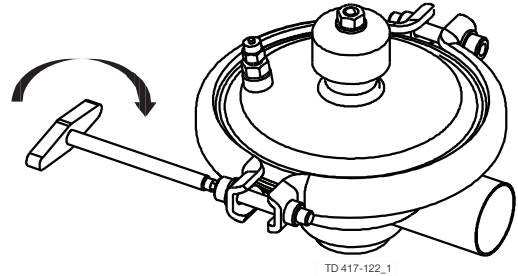

Step 2

CPMI-2:

Remove cover (7) together with the internal parts of the valve from valve body (16).

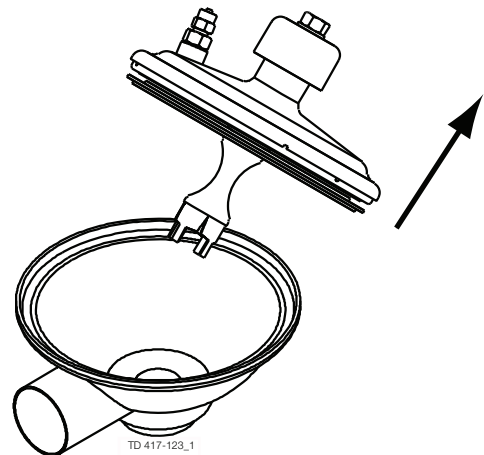

Step 3

CPMI-2 and CPMO-2 valves:

Remove top nut (1), washer (2) and top (3) from plug 15a or 15b).

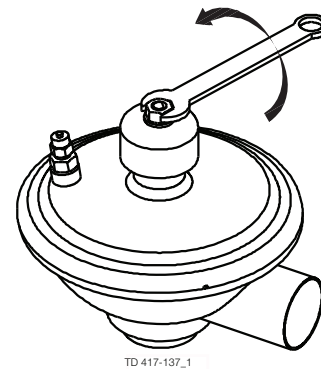

Step 4

Remove plug (15a) from the diaphragm unit and guide (9), or for CPMO-2 remove plug (15b) from valve body (16) and remove cover (7) and the internal parts of the valve.

CAUTION!

Ensure that cover (7) is turned downwards and plug (15a) is pulled upwards so that sectors (12) are not separated from diaphragms (10, 14).

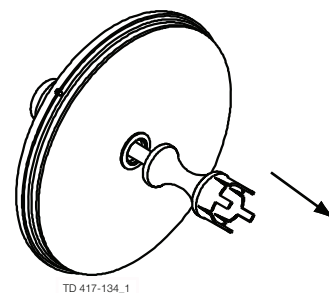

5 Maintenance

Study the instructions carefully.

The items refer to the parts list and service kits section.

Handle scrap correctly.

CPMI-2: Constant-Pressure Modulating Inlet. CPMO-2: Constant-Pressure Modulating Outlet.

Step 5

Remove lower inner ring (11) and lower diaphragm (14).

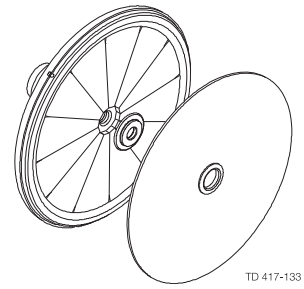

Step 6

Remove sectors (12).

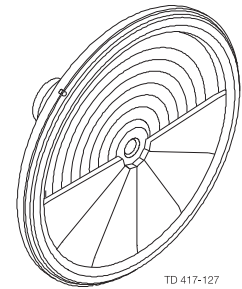

Step 7

Remove outer ring (13), upper inner ring (11) and upper diaphragm (10).

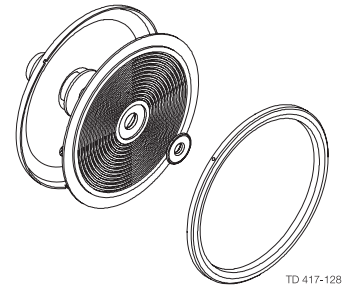

Step 8

Remove guide (9) from cover (7).

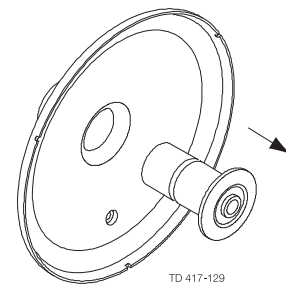

Step 9

Remove O-ring (8) from guide (9).

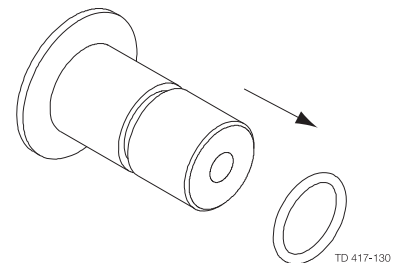

Study the instructions carefully.
The items refer to the parts list and service kits section.
Lubricate the guide, the sectors and the threads before assembly.
CPMI-2: Constant-Pressure Modulating Inlet. CPMO-2: Constant-Pressure Modulating Outlet.

Step 10
Replace the O-ring and the diaphragms.

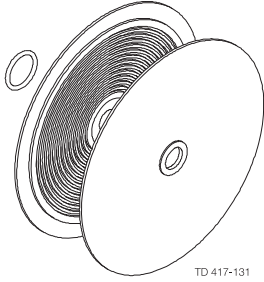

5.3 Assembly

Step 1
Fit O-ring (8)

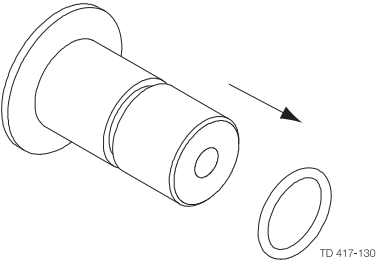

Step 2
Lubricate guide (9) and fit it into cover (7).
NOTE!
Turn cover (7) downwards before continuing.

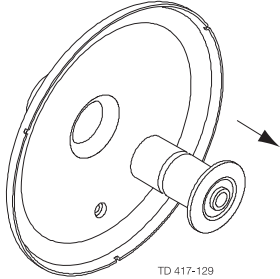

Step 3
Fit upper diaphragm (10), upper inner ring (11) and outer ring (13) on guide (9) and cover (7).
NOTE!
The upper diaphragm has a small recess. The outer ring must be fitted with the recess turned uppermost so that the indication hole is fixed opposite the indication hole in the cover.

Fit the correct diaphragm!

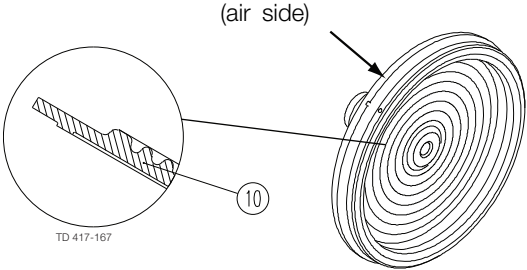

Step 4
Fit sectors (12) between upper inner ring (11) and outer ring (13).

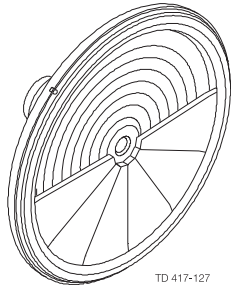

5 Maintenance

Study the instructions carefully.

The items refer to the parts list and service kits section.

Lubricate the guide, the sectors and the threads before assembly.

CPMI-2: Constant-Pressure Modulating Inlet. CPMO-2: Constant-Pressure Modulating Outlet.

Step 5

Fit lower inner ring (11) and lower diaphragm (14). Concentric grooves should point towards the steel segments.

Fit the correct diaphragm!

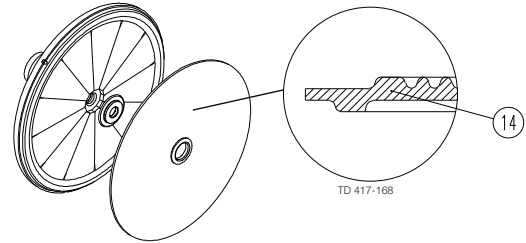

Step 6

CPMI-2:

Fit plug (15a) in the diaphragm unit and guide (9) until the flange of the plug contacts lower diaphragm (14).

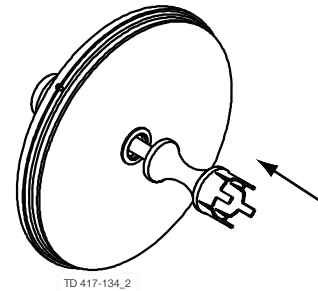

Step 7

Fit valve body (16) in cover (7).

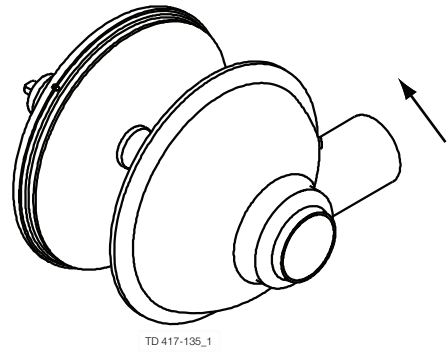

Step 8

CPMO-2:

Fit plug (15b) through valve body (16) and in the diaphragm unit and guide (9) until the flange of the plug contacts lower diaphragm (14).

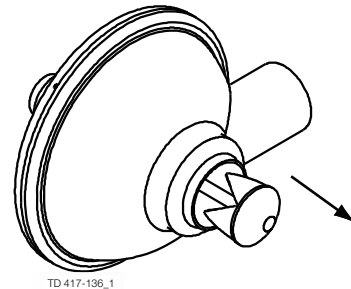

Study the instructions carefully.

The items refer to the parts list and service kits section.

Lubricate the guide, the sectors and the threads before assembly.

CPMI-2: Constant-Pressure Modulating Inlet. CPMO-2: Constant-Pressure Modulating Outlet.

Step 9

Fit top (3), washer (2) and top nut (1) on plug (15a or 15b).

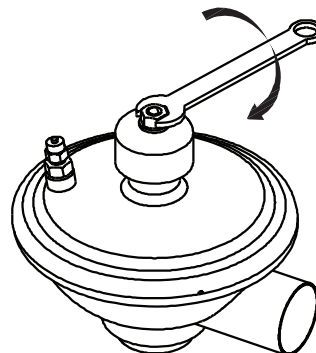

TD 417-137_2

Step 10

Fit and torque tighten clamp (6) to 10-15Nm (7.5-11 lbf-ft).

10-15Nm (7.5-11 lbf-ft).

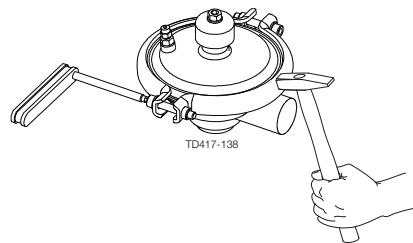

TD417-138

Step 11

Pre-use check:

Lift and lower the valve top several times to ensure that the valve operates smoothly.

Pay special attention to the warning!

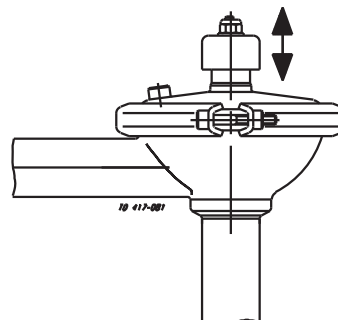

10 417-001

6 Technical data

*It is important to observe the technical data during installation, operation and maintenance.
Inform the personnel about the technical data.*

6.1 Technical data

The valves are remote-controlled by means of compressed air. A diaphragm/valve plug system reacts immediately to any alteration of the product pressure and changes position so that the preset pressure is maintained.

Standard design The CPMI-2 and CPMO-2 consist of a valve body with valve seat, cover, a valve plug with a diaphragm unit and a clamp.

The cover and the valve body are clamped together.

The valve body and the seat are welded together. The CPM-I-D60 consists of upper and lower valve bodies, an inlet tube, a cover, a valve plug with diaphragm unit and clamps. The cover and the valve bodies are clamped together.

Valve - data	
Max. product pressure	1000 kPa (10 bar) (145 psi)
Min. product pressure	Full vacuum
Temperature range	-10° C to +95° C (14°F to 203°F)
Temperature range (with upper diaphragm in PTFE/EPDM)	-10°C to +140°C (14°F to 284°F) (higher on request)
Air pressure	0 to 600 kPa (0 to 6 bar) (0 to 87 psi)
Flow range Kv (Lv), fully open ($\Delta p = 1\text{ bar}$) (14.5 psi)	Approx. 23 m ³ /h (101 gal/m)
Flow range Kv (Lv), low capacity ($\Delta p = 1\text{ bar}$) (14.5 psi) (Alternative size)	Approx. 2 m ³ /h (8.8 gal/m) (regulating area) Approx. 15 m ³ /h (66 gal/m) (CIP area)
Valve - materials	
Product wetted steel parts	AISI 316L/1.4404
Other steel parts	AISI 304
Upper diaphragm	Nitrile (NBR), (standard)
Lower diaphragm	PTFE covered EPDM rubber, (standard)
Alternative upper diaphragm	EPDM/PTFE, (for temperatures 95-140° C) (203°F to 284°F)
Alternative upper diaphragm	Solid Teflon (PTFE), (for temperatures above 140° C) (284°F)
Alternative lower diaphragm	Solid Teflon (PTFE), (for temperatures above 140° C) (284°F) O-ring Nitrile (NBR), (standard)
Alternative O-ring	Viton (FPM), (for temperatures above 95°C) (203°F)
Finish	Semi bright

Weight (kg)

Size	CPMI - 2			CPMO - 2			CPM-I-D60
	Kv 23	Kv 7	Kv 2/15	Kv 23	Kv 9	Kv 2/15	76 mm
Weight (kg)	5.5	5.5	5.5	5.5	5.5	5.5	10

Noise

One meter away from - and 1.6 meter above the exhaust the noise level of a valve actuator will be approximately 77dB(A) without noise damper and approximately 72 dB(A) with noise damper - Measured at 7 bars air-pressure.

It is important to observe the technical data during installation, operation and maintenance.
 Inform the personnel about the technical data.
 CPMI-2: Constant-Pressure Modulating Inlet.
 CPMO-2: Constant-Pressure Modulating Outlet.

6.2 Selection / pressure drop - capacity diagram

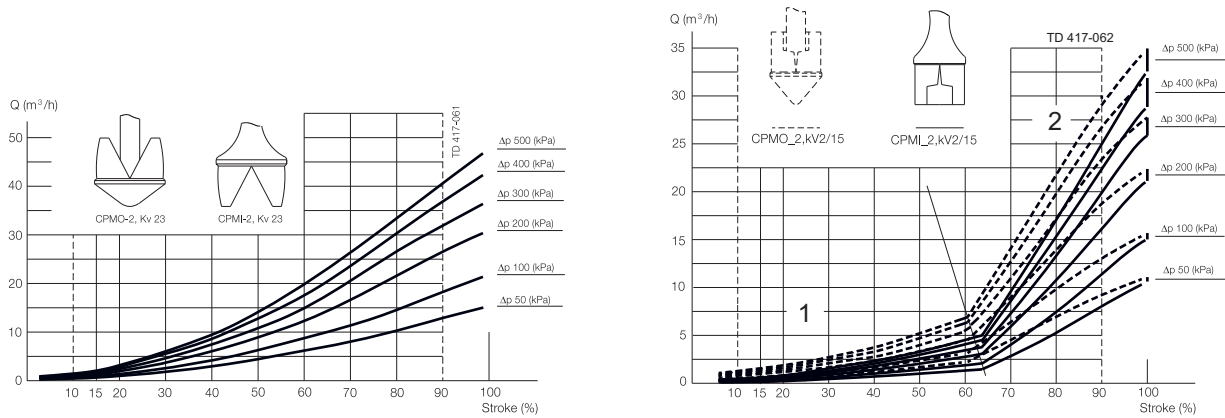

NOTE!
 For the diagrams the following applies:
 Medium: Water (20°C) (68°F).
 Measurement: In accordance with VDI 2173.

Example 1:
 CPMI-2:
 Pressure drop $\Delta p = 200 \text{ kPa}$. (29 psi)
 Flow $Q = 8 \text{ m}^3/\text{h}$. (35 gal/min)
 Select: CPMI-2, Kv 23 which at working point will be 48% open.

Example 2:
 CPMI-2:
 Pressure drop $\Delta p = 300 \text{ kPa}$.(43.5 psi)
 Flow $Q = 1 \text{ m}^3/\text{h}$. (4.4 gal/m)
 Select: CPMI-2, Kv 2/15 which at working point will be approx. 35% open equal to about 50% of the regulating area.

The drawing and the parts list include all items.

7.1 CPM-2

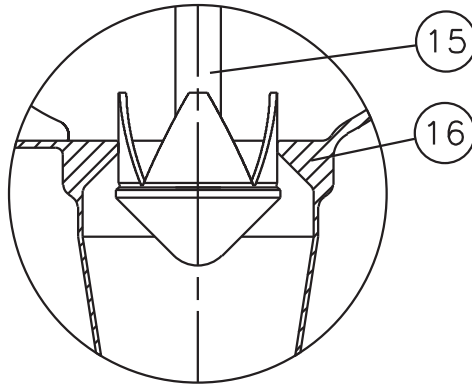

TD 417-146

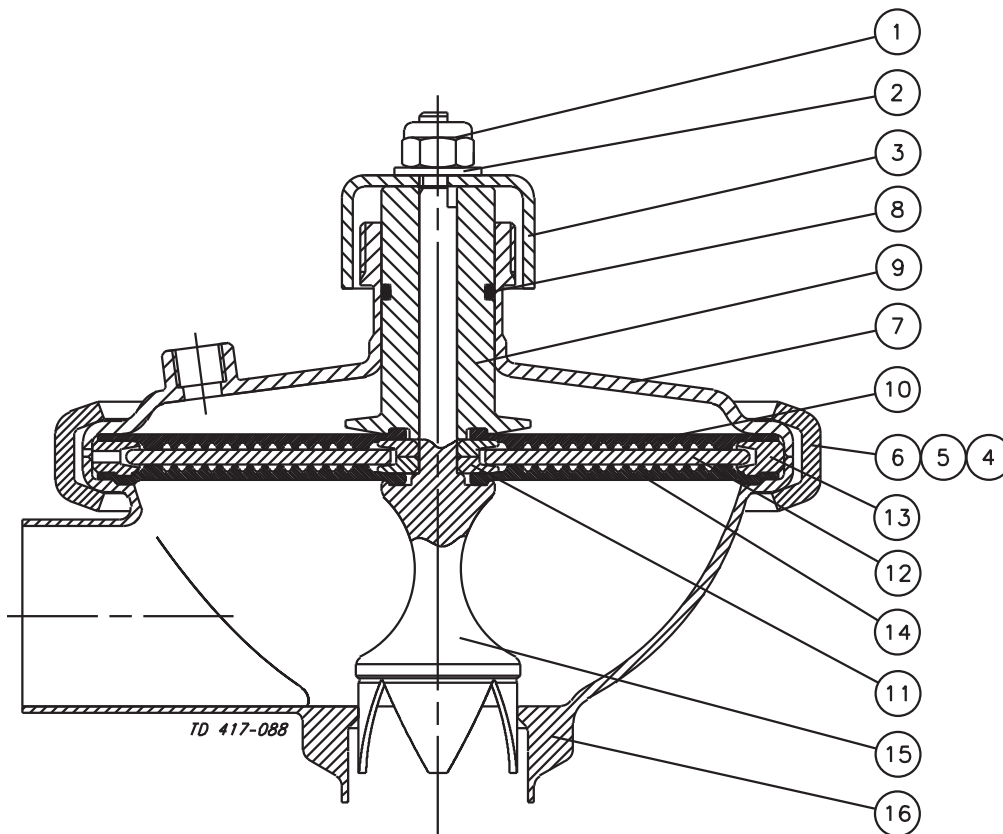

TD 417-088

7 Parts lists and service kit

The drawing and the parts list include all items.

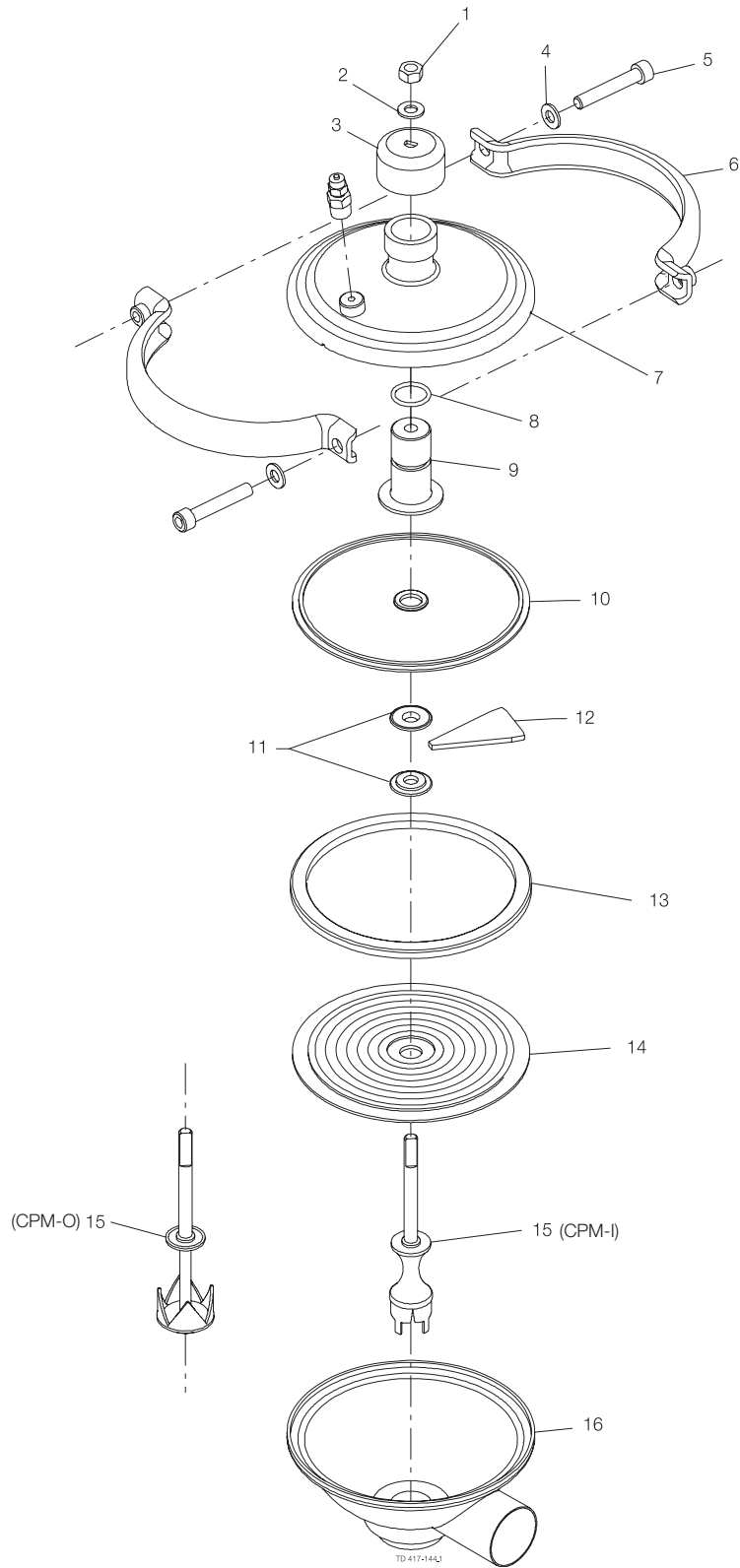

7 Parts lists and service kit

The drawing and the parts list include all items.

Parts list

Pos.	Qty	Denomination
1	1	Nut
2	1	Washer
3	1	Top
4	2	Washer
5	2	Screw
6	2	Clamp
7	1	Cover
8 □	1	O-ring
9	1	Guide
10 □	1	Upper diaphragm
11	2	Inner ring
12	12	Support sector
13	1	Outer ring
14 □	1	Lower diaphragm
15	1	Valve plug Kv23
16	1	Valve body

Service kits

Denomination	CPMI-2- Kv23	CPMO-2- Kv23	CPMI-2- Kv2/15 Kv7	CPMO-2- Kv2/15 Kv9
Service kit.				
Upper NBR and lower EPDM/PTFE, NBR O-ring	9611920218	9611920218	9611920218	9611920218
Upper and lower PTFE, FPM O-ring	9611920515	9611920515	9611920515	9611920515
Upper and lower EPDM/PTFE, FPM O-ring	9611920516	9611920516	9611920516	9611920516
Upper PTFE and lower EPDM/PTFE, NBR O-ring	9611920517	9611920517	9611920517	9611920517

Parts marked with □ are included in Service kit.

Recommended spare parts: Service kit.

900-125/0

The drawings and the parts list include all item

7.2 Booster

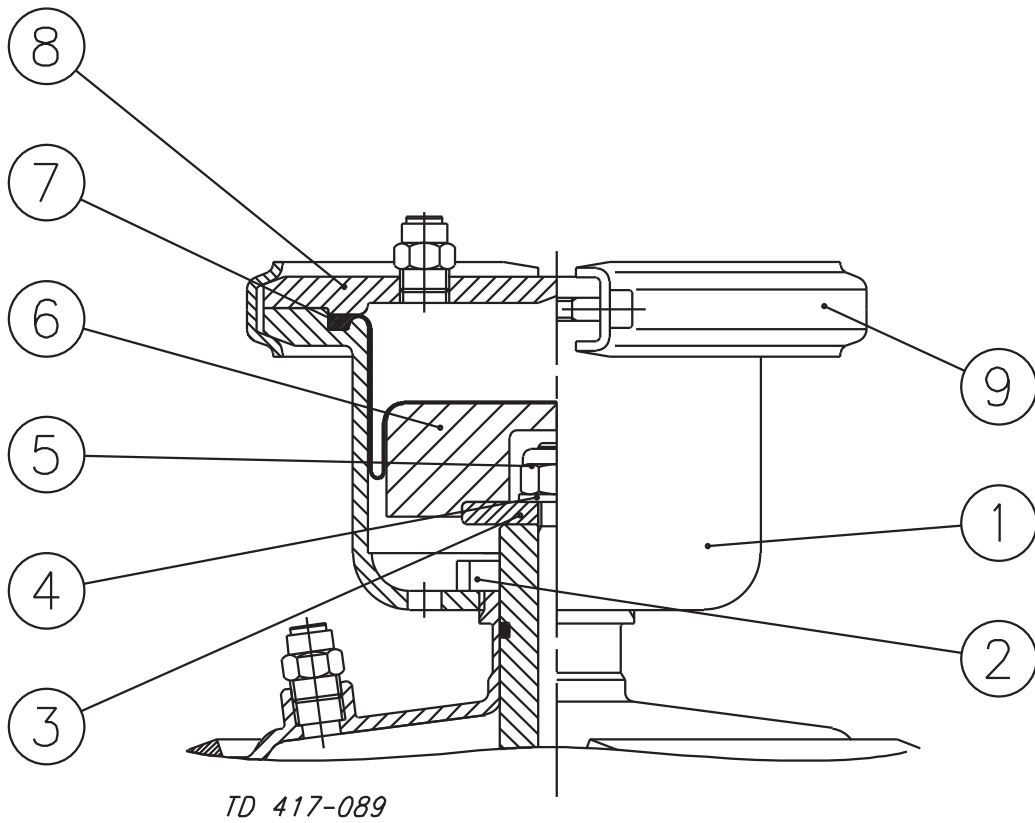

7 Parts lists and service kit

The drawings and the parts list include all item

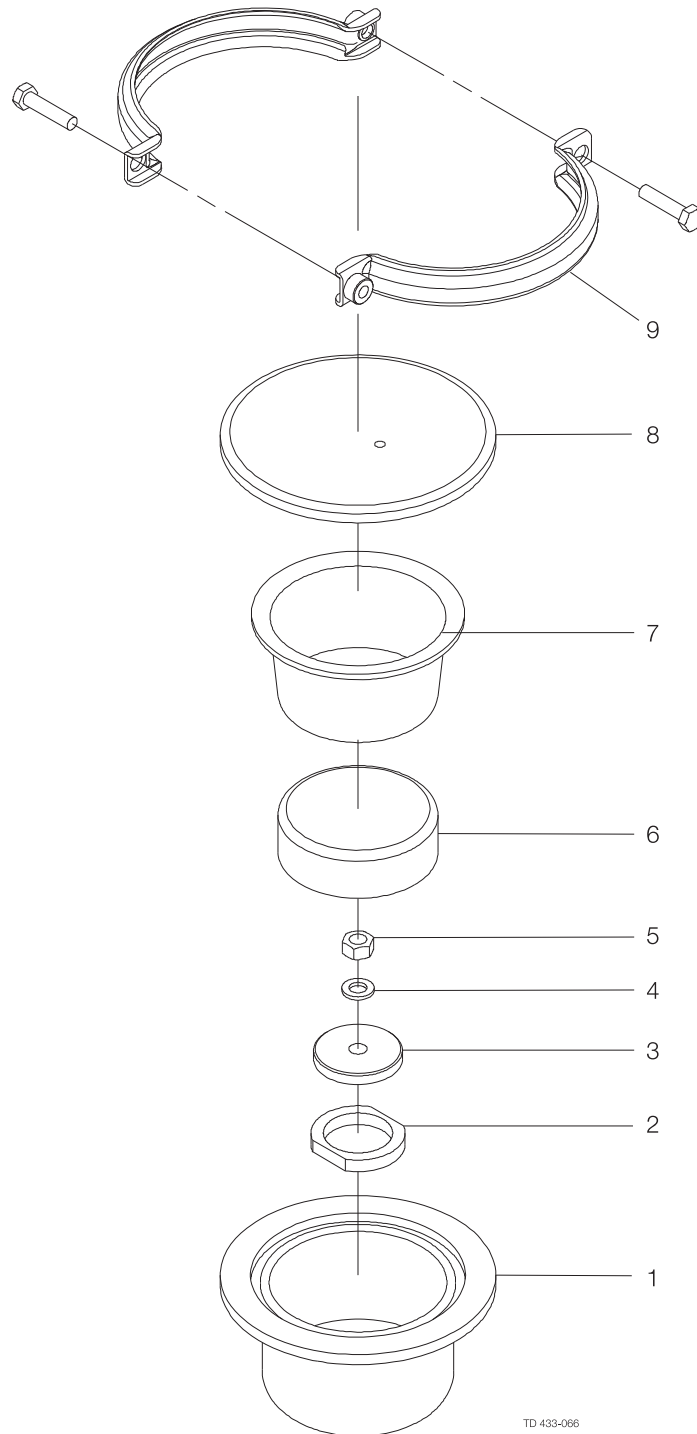

The drawings and the parts list include all item

Parts list

Pos.	Qty	Denomination
1	1	Booster housing
2	1	Lock nut
3	1	Washer
4	1	Spring washer
5	1	Nut
6	1	Booster piston
7	1	Diaphragm
8	1	Booster cover
9	1	Clamps and screws

How to contact Alfa Laval

Contact details for all countries are continually updated on our website.

Please visit www.alfalaval.com to access the information directly.

© Alfa Laval Corporate AB

This document and its contents is owned by Alfa Laval Corporate AB and protected by laws governing intellectual property and thereto related rights. It is the responsibility of the user of this document to comply with all applicable intellectual property laws. Without limiting any rights related to this document, no part of this document may be copied, reproduced or transmitted in any form or by any means (electronic, mechanical, photocopying, recording, or otherwise), or for any purpose, without the expressed permission of Alfa Laval Corporate AB. Alfa Laval Corporate AB will enforce its rights related to this document to the fullest extent of the law, including the seeking of criminal prosecution.