

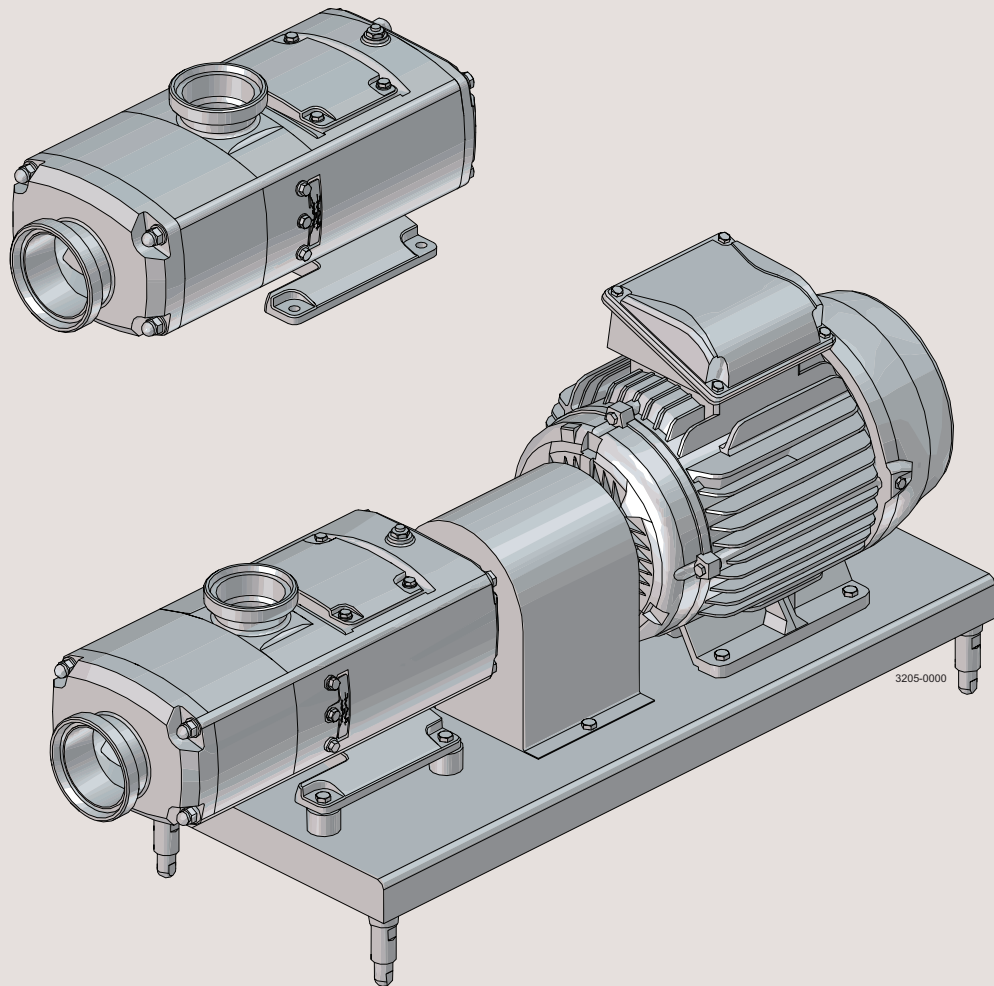

Instruction Manual

Alfa Laval OS Twin Screw Pump



100000817-EN2

2021-03

Original manual



www.sk-online.com

The information herein is correct at the time of issue but may be subject to change without prior notice

1. EC Declaration of Conformity	4
2. General description	6
2.1. General description	6
3. Safety	7
3.1. Important information	7
3.2. Warning signs	8
3.3. Safety precautions	9
3.4. Recycling information	11
4. Installation	12
4.1. Unpacking, Handling and Storage	12
4.2. System design and installation	14
4.3. Flushing seal arrangement and pre-start up checks	18
5. Maintenance	20
5.1. Cleaning in place (CIP)	20
5.2. Maintenance schedule	21
5.3. Dismantling	22
5.4. Assembly	30
5.5. Maintenance seals - Single Seal - All Models	39
5.6. Single Flushed Seal - All Models	41
5.7. Double Seal OS1x	43
5.8. Double Seal OS2x, OS3x, OS4x	46
5.9. Heating (option)	49
5.10. Rectangular Inlet (option)	50
5.11. Trouble shooting	51
6. Technical data	52
6.1. Technical data	52
6.2. Pumphead Clearance information	54
7. Parts list	55
7.1. Twin Screw Pump Range (All Models)	55

1 EC Declaration of Conformity

Revision of Declaration of Conformity 2009-12-29

The Designated Company

Alfa Laval Eastbourne, Alfa Laval Ltd
Company Name

Birch Road, Eastbourne, East Sussex BN23 6PQ
Address

+44 (0) 1323 412555
Phone No.

hereby declare that

Pump
Designation

OS12, OS14, OS16, OS22, OS24, OS26, OS32, OS34, OS36, OS42, OS44, OS46
Type

From serial number 10.000 to 1.000.000

is in conformity with the following directive with amendments:
- Machinery Directive 2006/42/EC

The person authorised to compile the technical file is the signer of this document

Global Product Quality Manager
HFH
Title

Lars Kruse Andersen
Name

Kolding
Place

2021-03-31
Date

Signature



2 General description

2.1 General description

The Alfa Laval OS range of pumps is of conventional Twin Screw pump design with the positive displacement being provided by non-contacting, contra rotating screws within a fully swept pump chamber.

Handling from low to high viscosity pumped media, the pump's characteristic smooth, low shear pumping action is ideal in application areas such as Dairy, Food, Beverage, Home & Personal Care Industries.

The pump can also be run at high speeds for CIP (clean in place) cleaning of the pump and system.

Drawing shows only mounted unit

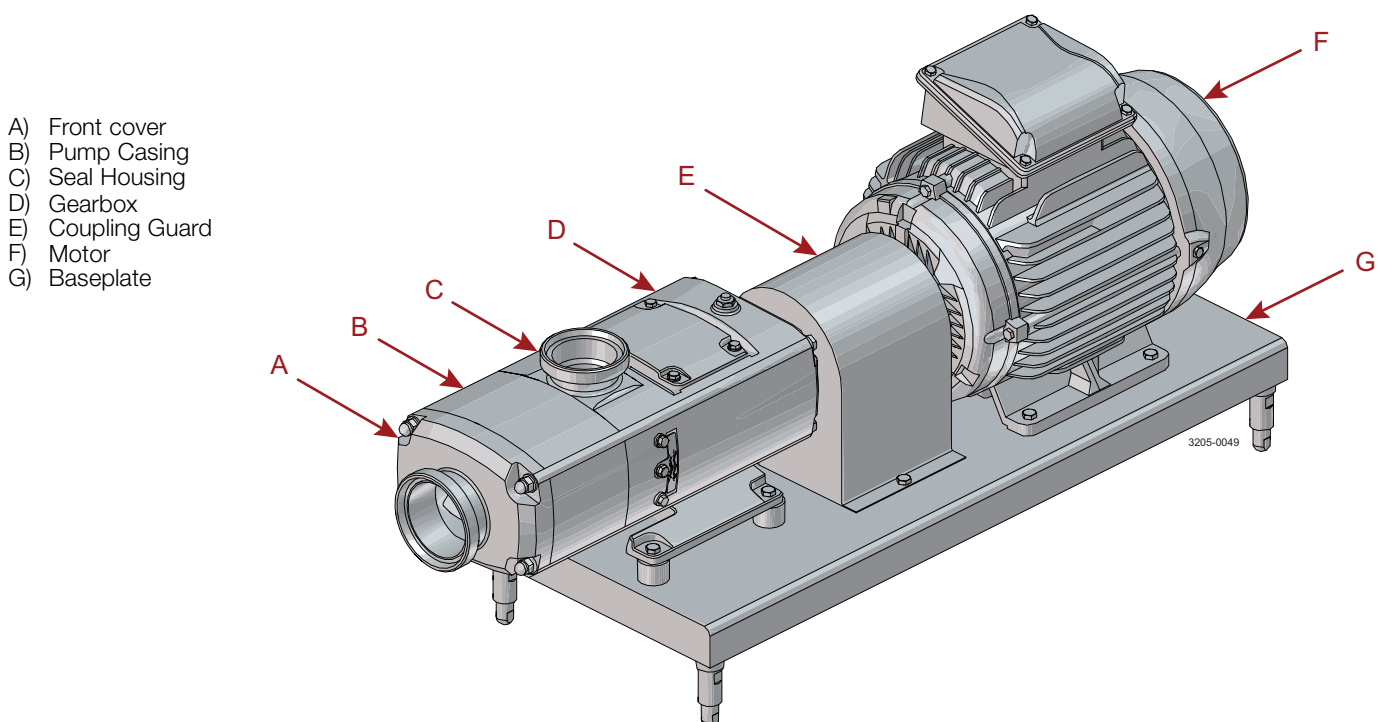

Pump duty conditions

The pump should only be used for the duty for which it has been specified. The operating pressure, speed and temperature limits have been selected at the time of order and **MUST NOT** be exceeded. These details are stated on the original order documentation and if not available may be obtained from your supplier quoting pump model and serial number.

Noise levels

Under certain operating conditions pumps and/or drives and/or the systems within which they are installed can produce sound pressure levels in excess of 80 dB[A]. When necessary, protection against noise should be taken.

*Unsafe practices and other important information are emphasized in this manual.
Warnings are emphasized by means of special signs.
Always read the manual before using the pump!*

3.1 Important information

WARNING

Indicates that special procedures must be followed to avoid serious personal injury.

CAUTION

Indicates that special procedures must be followed to avoid damage to the pump.

NOTE

Indicates important information to simplify or clarify procedures.

This Instruction manual is designed to provide the user with the information to perform tasks safely for all phases in the life time of the product supplied.

The User shall always read the safety section first. Hereafter the User can skip to the relevant section for the task to be carried out or for the information needed.

This is the complete manual for the supplied product.

Skills for personal:

Operators:

The operators shall read and understand the instruction manual for the supplied product

Maintenance personnel:

The maintenance personnel shall read and understand the instruction manual.

The maintenance personnel or technicians shall be skilled within the field required to carry out the maintenance work safely.

Trainees:

Trainees can perform tasks under the supervision of an experienced employee.

People in general:

The public shall not have access to the supplied product.

How to contact Alfa Laval

Contact details for all countries are continually updated on our website.

Please visit www.alfalaval.com to access the information directly.

3 Safety

*Unsafe practices and other important information are emphasized in this manual.
Warnings are emphasized by means of special signs.
Always read the manual before using the pump!*

3.2 Warning signs

General warning:



Dangerous electrical voltage:

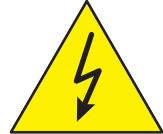

Caustic agents:



Hot surfaces:



Unsafe practices and other important information are emphasized in this manual.

Warnings are emphasized by means of special signs.

Always read the manual before using the pump!

3.3 Safety precautions

Installation:

Always read the technical data thoroughly. (See chapter 6 Technical data).

Never start in the wrong direction of rotation with liquid in the pump.

Never put your hands or fingers inside the port connections or anywhere close to rotating shafts.



Always have the pump electrically connected by authorized personnel. (See the motor instruction supplied with the drive unit)

Alfa Laval recommends the supply disconnecting device shall be in accordance with EN 60204-1.

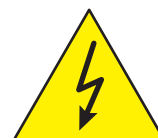

Operation:

Always read the technical data thoroughly. (See chapter 6 Technical data)

Never stand on the pump or pipelines.

Never run the pump with either the suction side or the pressure side blocked.

Never put your hands or fingers inside the port connections or anywhere close to rotating parts.

Never run the pump unless fully assembled and all guards are securely fitted, i.e. pump head must not be removed from gearcase.

Always ensure any guards are securely fitting and in good condition.



Never touch the pump or the pipelines when pumping hot liquids or when sterilising.

In certain operating conditions external surfaces of the pump and/or ancillary equipment may exceed 80°C. As such users should avoid touching the pump and/or ancillary equipment during operation taking precautions if it is unavoidable to do so.



Only handle toxic and acidic liquids in accordance with the manufacturers instructions and recommendations.

Maintenance:

Always read the technical data thoroughly. (See chapter 6 Technical data)

Always ensure adequate Personal Protective Equipment (PPE) is worn during any maintenance activities.

Never service the pump when it is hot.



The pump and the pipelines must **never** be pressurised when the pump is serviced.

Never put your hands or fingers inside the port connections or anywhere close to rotating parts.

Installation and operation of the pump must always comply with any local health and safety regulations.

Any hazardous and/or hot, drained or leaked, liquid shall be disposed in compliance with any local health and safety regulations. If requested at the time of quotation, the equipment can be supplied with a means of safe containment of any hazardous and/or hot, drained or leaked liquid (Drip Pan).

Always ensure the power supply is disconnected (in an off position) and is locked out to prevent accidental operation.

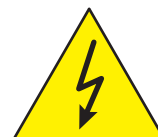

Please refer to any motor/geared motor and coupling operating manuals supplied with the unit for maintenance instructions.



Always ensure pump and ancillary equipment has been allowed to cool before touching.

3 Safety

Unsafe practices and other important information are emphasized in this manual.

Warnings are emphasized by means of special signs.

Always read the manual before using the pump!

Transportation:

Transportation of the pump or the pump unit:

Never lift or elevate in any way other than described in this manual

Always drain the pump head and accessories of any liquid

Always ensure that no leakage of lubricants can occur

Always transport the pump in it's upright position

Always ensure that the unit is securely fixed during transportation

Always use original packaging or similar during transportation

Always use a suitable transport device i.e. forklift truck or pallet lifter

3.4 Recycling information

Recycling information.

• Unpacking

- Packing material consists of wood, plastics, cardboard boxes and in some cases metal straps.
- Wood and cardboard boxes can be reused, recycled or used for energy recovery.
- Plastics should be recycled or burnt at a licensed waste incineration plant.
- Metal straps should be sent for material recycling.

• Maintenance

- During maintenance oil and wear parts in the machine are replaced.
- All metal parts should be sent for material recycling.
- Worn out or defective electronic parts should be sent to a licensed handler for material recycling.
- Oil and all non metal wear parts must be taken care of in agreement with local regulations.

• Scrapping

- At end of use, the equipment shall be recycled according to relevant, local regulations. Beside the equipment itself, any hazardous residues from the process liquid must be considered and dealt with in a proper manner. When in doubt, or in the absence of local regulations, please contact the local Alfa Laval sales company.
-

4 Installation

4.1 Unpacking, Handling and Storage

Step 1

Always ensure any personnel undertaking lifting operations have the suitable experience and training to do so safely. Always ensure any lifting equipment used is in good condition and has been suitably tested, using lifting logs when applied. Always refer to the pump weights guide (Section 6) and ensure any lifting equipment used is rated for and used within the load limits.

Always ensure that the lifting points are in line with the centre of gravity and adjust lifting point if necessary. Always keep an eye on the load and stay clear during the lifting operation.

The diagram below show examples of how the equipment can be lifted, however the user is to ensure this can be done safely with the equipment at hand:

Pump with drive unit

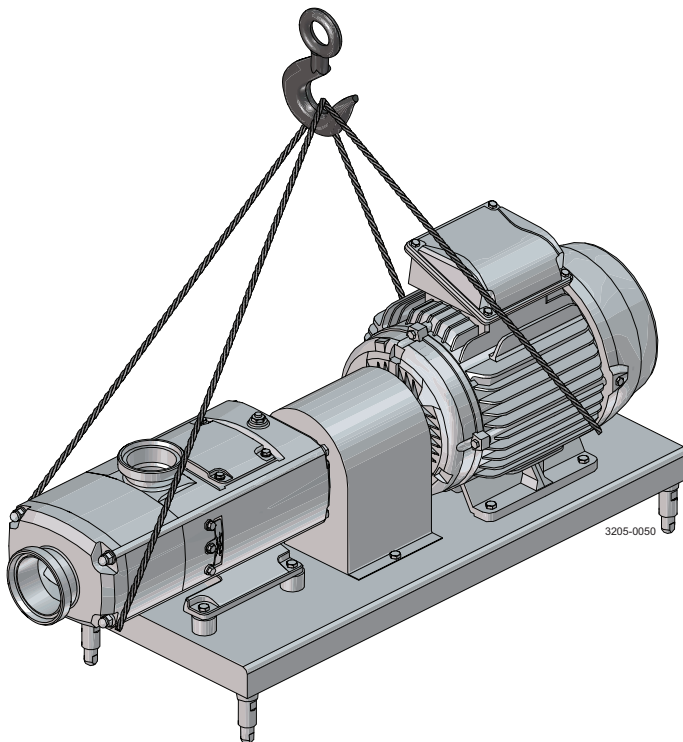

Bareshaft pump

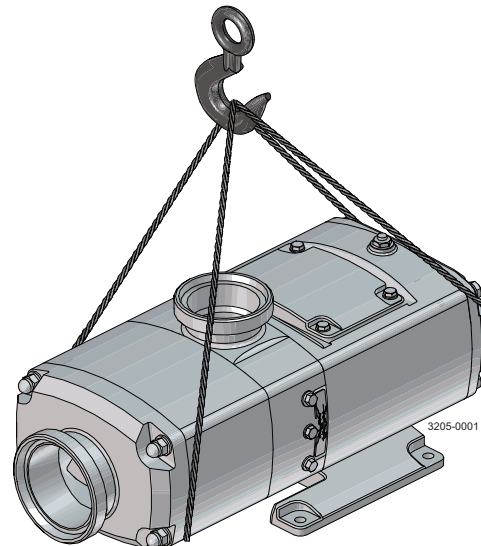

Step 2

On receipt always:

- Check the delivery note against the goods received.
 - If motorised, check that the drive instructions are available.
 - Be careful not to discard any manuals that may be enclosed with the packaging.
 - Inspect the packing for signs of damage in transit.
 - Carefully remove the packing away from the pump.
 - Inspect the pump for any visible signs of damage.
 - Clean away the packing from the pump port connections.
 - Report any damage immediately to the carrier.
-

Step 3

After receipt and inspection, if the pump is not to be installed immediately, the pump should be repacked in the original packaging and placed in suitable storage. The following points should be noted:

- Plastic or gasket type port covers should be left in place.
 - Pumps received wrapped with corrosion inhibiting treatment material should have wrapping replaced.
 - A clean, dry storage location free from vibration should be selected. If a moist or dusty atmosphere is used for storage, further protect the pump or unit with a suitable cover.
 - A clean, dry storage location free from vibration and without direct sunlight or UV light should be selected.
 - Temperature range between -5 to +40° C (23 to 104° F)
 - Relative humidity <60%.
 - If a moist or dusty atmosphere is used for storage, further protect the pump or unit with a suitable cover.
 - No exposure to corrosive substances, including those contain in the air.
 - Rotate the pump/pump unit by hand weekly, to prevent bearing damage.
 - All associated ancillary equipment should be treated similarly.
-

4 Installation

To ensure optimum operation it is important that any pump unit is installed correctly. When designing a pumping system the following should be taken into consideration.

4.2 System design and installation

Design:

- Confirm the Net Positive Suction Head (NPSH) available from the system exceeds the NPSH required by the pump, as this is crucial for ensuring the smooth operation of the pump and preventing cavitation.
- Avoid suction lifts and manifold/common suction lines for two pumps running in parallel, as this may cause vibration or cavitation.
- Protect the pump against blockage from hard solid objects e.g. nuts, bolts welding slag etc. Also protect the pump from accidental operation against a closed valve by using relief valves, pressure switches or current limiting devices.
- Fit suction and discharge monitor points for diagnostic purposes.- Fit valves, if two pumps are to be used on manifold/common discharge lines.
- Make the necessary piping arrangements if flushing is required for the seal.
- Allow at least 1 m for pump access/maintenance all around the pump.
- Do not subject rotary lobe pumps to rapid temperature changes, as pump seizure can result from thermal shock.

Pipework:

The pump must not be used to support piping. All inlet and outlet piping on the pump unit must be independently supported. Failure to observe this may distort the pump head components or pump assembly and cause serious permanent damage.

Direction of flow:

The standard direction of flow as built is indicated by arrows affixed to the pump showing the direction of flow and drive shaft rotation. Reverse flow direction is possible for short durations if reverse flow pressure limits are observed. If permanent reverse flow operation is required, then changes to the bearing configuration and screw housing orientation need to be made to ensure safe operation but with reduced maximum pressure limits. Failure to do so may lead to pump damage. For pressure limits please see 6 Technical data.

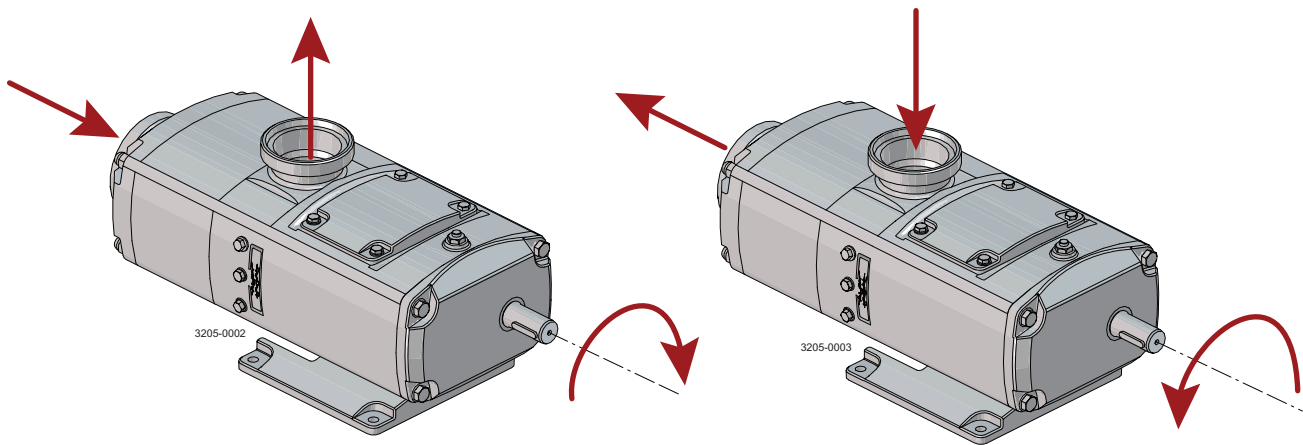

Inlet axial in the front cover
Outlet top in seal housing

Inlet top in the seal housing
Outlet axial in front cover

4 Installation

To ensure optimum operation it is important that any pump unit is installed correctly. When designing a pumping system the following should be taken into consideration.

Pump Lubrication:

The pump will be supplied filled with food grade oil with NSF/NSDA H1 Approval. The oil level can be checked using the oil site glass on the side of the gearbox. Oil level must be checked with the pump not running.

It is recommended to change the oil every 4000 hours of pump operation.

Oil should be drained by removing the oil drain plug on the side of the gearbox and filled by removing the gearbox vent plug.

Recommended Oils

Food Grade Oil (NSF H-1) -20°C to +150°C (-4°F to 302°F)
Jax Flow-Guard Synthetic ISO100
Castrol Optileb GT Cassida FL 100
Shell / Fusch Cassida Fluid FL or HF 100
Klüber Klüberoil 4 UH1 6-100
Mobil SHC Cibus 100

All oils are poly-alpha-olefin based please check before mixing with other base oils.

Baseplate Foundations

Pumps when supplied with a drive unit are normally mounted on a baseplate. Our standard baseplates have pre-drilled fixing holes to accept base retaining bolts. To provide a permanent rigid support for securing the pump unit, a foundation is required which will also absorb vibration, strain or shock on the pumping unit. Methods of anchoring the baseplate to the foundation are varied, they can be studs embedded in the concrete either at the pouring stage as shown below, or by use of epoxy type grouts. Alternatively, mechanical fixings can be used.

The foundation should be approx. 150 mm (6 inch.) longer and wider than the baseplate. The depth of the foundation should be proportional to the size of the complete pump unit. For example, a large pump unit foundation depth should be at least 20 times the diameter of the foundation bolts.

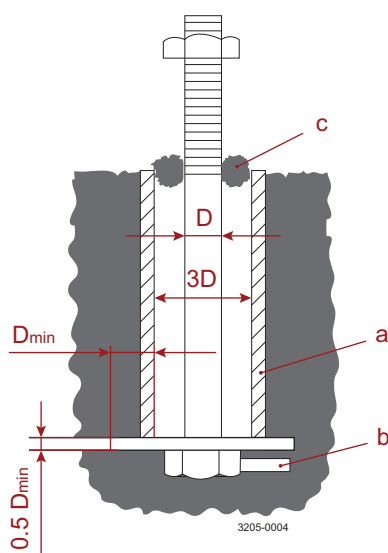

- a) Sleeve 3D
- b) Lug welded to bolt head
- c) Waste put around bolt before pouring concrete

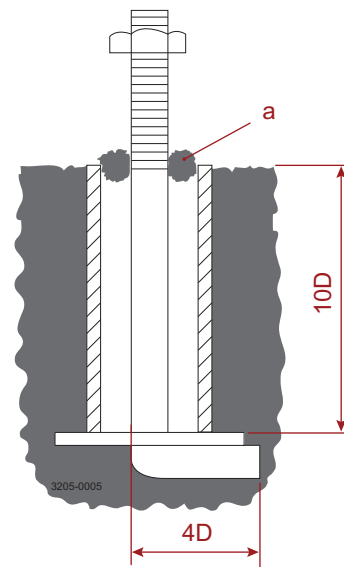

- a) Foundation surface left through to anchor ground

The drawing above shows two typical methods for foundation bolt retaining. The sleeve allows for "slight" lateral movement of the bolts after the foundation is poured. Rag or wastepaper can be used to prevent the concrete from entering the sleeve while the foundation is poured. A minimum of 14 days is normally required to allow the curing of the concrete prior to pump unit installation.

4 Installation

To ensure optimum operation it is important that any pump unit is installed correctly. When designing a pumping system the following should be taken into consideration.

Ball Foot Baseplate with Adjustable Feet

The pump can be supplied with an optional ball foot baseplate with height adjustable feet.

When used:

Ensure the floor is level and is able to support the weight of the complete unit

Ensure the unit is supported by all feet equally

3A Approved Ball Foot Baseplate with Adjustable Feet

For 3A approved mounted pumps a 3A approved ball foot baseplate is required which has additional sealant applied.

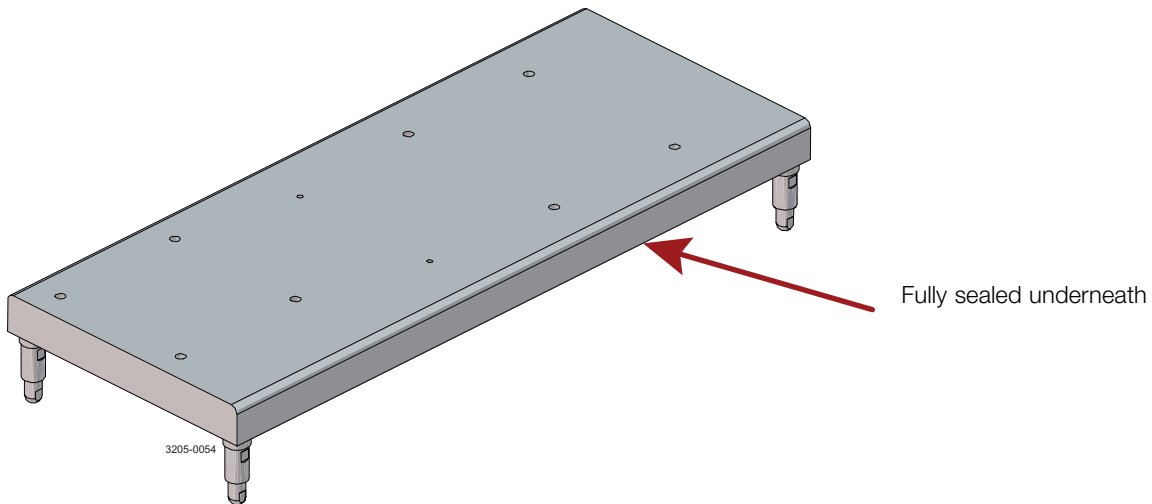

4 Installation

To ensure optimum operation it is important that any pump unit is installed correctly. When designing a pumping system the following should be taken into consideration.

Coupling alignment:

Before the pump unit is installed it is important to ensure that the mounting surface is flat to avoid distortion of the baseplate, which may cause pump/motor shaft misalignment and pump/motor unit damage. Once the baseplate has been secured, the pump shaft to motor shaft coupling alignment should be checked and adjusted as necessary. This is achieved by checking the maximum angular and parallel misalignment for the couplings as stated below. Shaft alignment that is outside the stated tolerances can be corrected by applying shims under the motor or pump foot, or, by moving the pump or drive sideways on the baseplate. All bolts that have been loosened should be re-tightened to the stated torque figure.

The following dimensions and tolerances apply to standard supply couplings only.

Parallel misalignment

Measure 4 positions at 90° around coupling

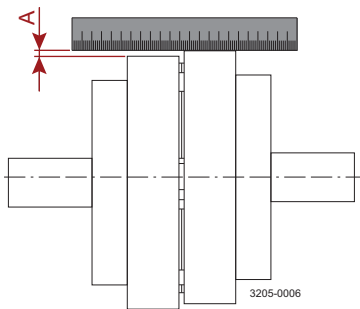

Coupling size	Dimension A Maximum
70	0.3 mm (0.011 inch)
90	0.3 mm (0.011 inch.)
110	0.3 mm (0.011 inch.)
130	0.4 mm (0.015 inch.)
150	0.4 mm (0.015 inch.)
180	0.4 mm (0.015 inch.)
230	0.5 mm (0.019 inch.)
280	0.5 mm (0.019 inch.)

Angular misalignment

Measure 4 positions at 90° around coupling

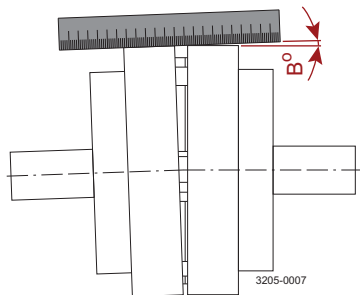

Coupling size	Dimension B Maximum
70	1°
90	1°
110	1°
130	1°
150	1°
180	1°
230	1°
280	1°

Assembled length

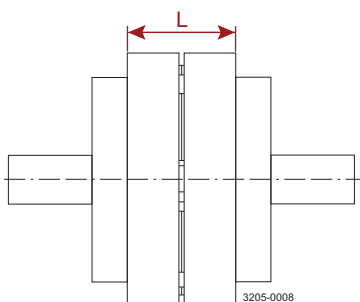

Coupling size	Dimension L ± 1.0mm (0.04 inch.)
70	25 mm (0.98 inch.)
90	30.5 mm (1.20 inch.)
110	45 mm (1.77 inch.)
130	53 mm (2.08 inch.)
150	60 mm (2.36 inch.)
180	73 mm (2.87 inch.)
230	85.5 mm (3.36 inch.)
280	105.5 mm (4.15 inch.)

Recommended bolt torques.

Thread Diameter	M6	M8	M10	M12	M16	M20	M24
Torque (Nm)	6	15	30	50	120	150	200
Torque (ft lbf)	4.4	11.0	22.1	36.8	88.5	110.6	147.5

4 Installation

4.3 Flushing seal arrangement and pre-start up checks

Step 1

A flushed seal arrangement is fitted in order to cool or clean the seal area.

It is important that:

- The flush is correctly connected on both sides for the seals (see below).
- A compatible flushing fluid is used and supplied at the correct pressure and flow rate (See below).
- The flush is turned on at the same time/prior to starting the pump and turned off at the same time/after stopping the pump.

Step 2

Connecting the flush

The following equipment is strongly recommended when using a flushing system:

- Control valve and pressure gauge, to enable the correct flushing pressure to be obtained and monitored.
- Isolation valve and check valve, so that the flush can be turned off, and to stop any unwanted substances flowing in the wrong direction.
- A method of visibly indicating flushing fluid flow.

Step 3

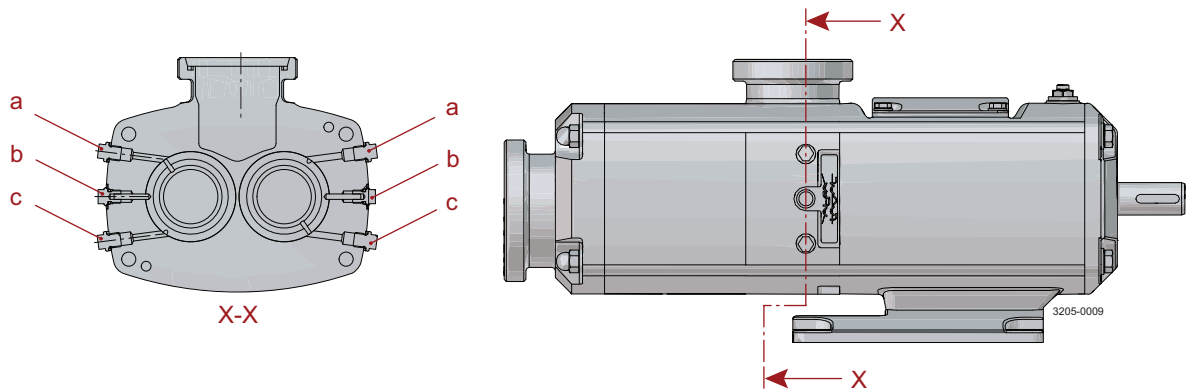

- a) Outlet
- b) Seal retention
- c) Inlet

Flush Connection Size:

Pump Model	Std. Connection	Opt. Connection
OS1x	G 1/4"	1/4" NPT
OS2x	G 1/4"	1/4" NPT
OS3x	G 1/4"	1/4" NPT
OS4x	G 1/2"	1/2" NPT

Step 4

Flushing fluid

The choice of flushing fluid is dependent upon the fluid being pumped and duty conditions i.e. pressure and temperature. Usually water is used for cooling or flushing water soluble products. For single and double flushed mechanical seal arrangements the temperature of flush media should never be allowed to exceed the maximum temperature of the pumped media. For advice on selecting a suitable flushing fluid please contact pump supplier.

Step 5

Flushing pressure and flow rate

Single flushed mechanical seal 0.5 bar (7 psi) maximum. Any further increase in pressure will result in lip seal failure.

Double flushed mechanical seal 16 bar (232 psi) maximum or 6 bar (87 psi) over product pressure.

The flushing flow rate must be adequate to ensure that the temperature limitation of the seals is not exceeded.

Minimum flow rate required per shaft seal is 30 l/hr (0.13 us gpm)

Step 6

Pre-start up checks

- Check the pipework system has been purged to remove debris.
 - Check all obstructions have been removed from pipework and pump.
 - Check pump connections and pipework joints are tight.
 - Check lubrication levels are correct.
 - Check seal flushing is connected if applicable.
 - Check all safety guards are in place.
 - Check that inlet and outlet valves are open.
-

5 Maintenance

5.1 Cleaning in place (CIP)

The pump can be manually cleaned or cleaned in place (CIP). The following is an example of a typical CIP procedure. However specific advice for each application should be sought from the pump supplier.

Typical CIP procedure

1. Flush through the system with clean cold water or bore water (6°C) (43°F).
 2. Run hot caustic soda (70-80°C) (158-176°F) at 2.5% dilution through the system for 20-30 minutes.
 3. Final flush through with clean cold water again.
-

Warnings

- **Never** touch the pump or the pipelines as they can be extremely hot!
 - Do not subject the pump to rapid temperature changes during CIP procedures, as pump seizure can result from thermal shock. A suitable by-pass is recommended.
 - **Always** handle cleaning agents with care and follow manufactures instructions and safety datasheets.
 - **Always** rinse well with clean water after using a cleaning agent.
-
- **Always** use rubber gloves and protective goggles when handling caustic agents.
-
- **Always** store/discharge cleaning agents in accordance with current rules/directives.



CIP process using separate CIP pumps/systems:

If CIP pumps or a central CIP unit are used for CIP, i.e. cleaning fluids simply flow through the OS twin screw pump as with all other system parts, please note the following:

- If the system pressure is >1bar, the OS pump must be locked to prevent turbinning.
- If the pump runs slowly with the flow, the inlet pressure must be <1 bar, i.e. a negative differential pressure should be avoided.

SIP method

Dry running of the pump with steam will cause damage to the shaft seal.

When steam is flowing through the pipes, make sure that the pump is switched off.

Slow rotation with the shaft is possible if the pump has a single flushed seal or double shaft seal (<100 1/min).

The OS twin screw pumps are only suitable for the SIP (Sterilisation In Place) method in consultation with Alfa Laval.

Suitability depends on the choice of elastomers. The maximum sterilisation temperature is 145°C (293°F).

5.2 Maintenance schedule

It is advisable to install pressure gauges on both sides of the pump so that any problems within the pump/pipework can be monitored.

Maintenance schedule

Your weekly schedule should include:

- Checking the seals for leakage.
- Checking the lip seals for leakage.
- Check pumping pressures are within expected duty.
- Check oil level in the gearcase with pump stationary.
- Check that any guarding is securely affixed in position and is in good condition.

Checks should be carried out when the pump is not operational, and any electrical supply has been safely disconnected and locked so accidental operation cannot occur. In certain operational circumstances the pump will pose a thermal hazard and as such should not be touched during operation. After shutdown the pump unit should be allowed time to cool to ambient temperature.

Recommended Spare Parts

The table shows recommended spare parts that should be retained within your maintenance schedule.

Part description	Quantity
Service kit for the mechanical seal	1
Profiled elastomer kit for wet end	1

5 Maintenance

5.3 Dismantling

Step 1

Before disassembling the pump refer to safety precautions. See exploded view drawings (chapter 7 Parts list.)

Removing pump cover and pump casing

1. Remove front cover nuts, washers, front cover, front cover elastomer and pump casing.

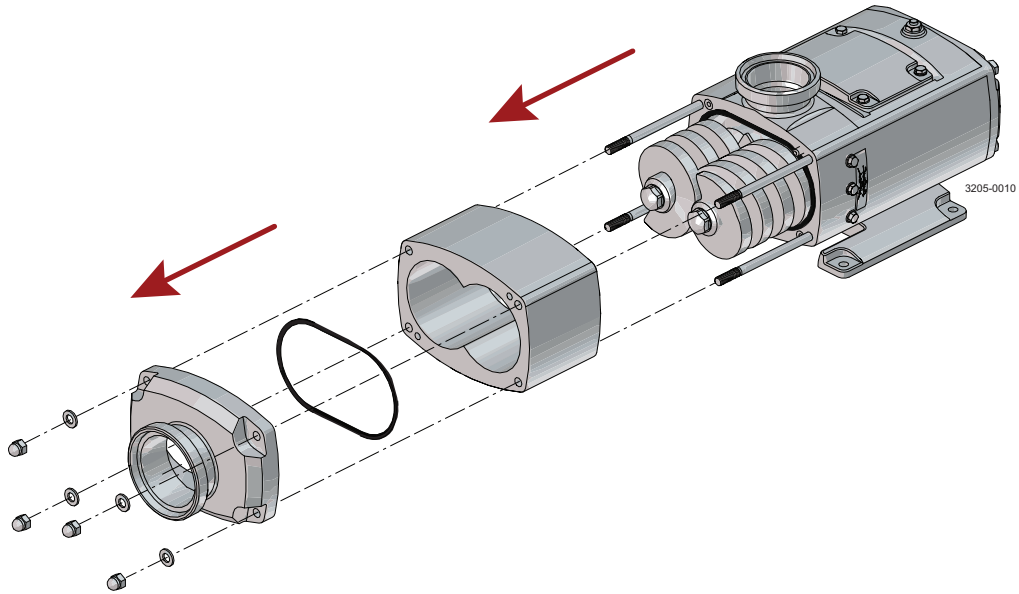

Step 2

Removing feed screws

1. Insert a plastic/wooden block between the feed screw leading edge and opposite screw to prevent from turning.

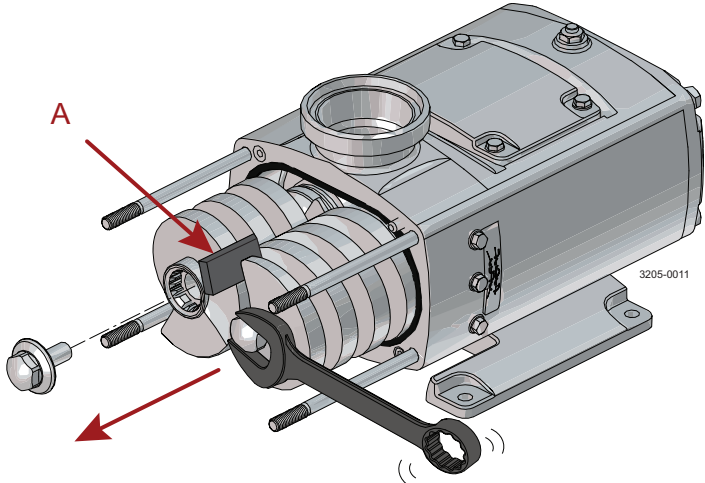

A) Plastic/wooden block

- 2. Remove feed screw nuts, feed screw nut elastomer and feed screws
NOTE: the identification marking on the screws and the shafts.
- 3. Remove the pump casing elastomer and shaft sealing elastomers if these are to be replaced.

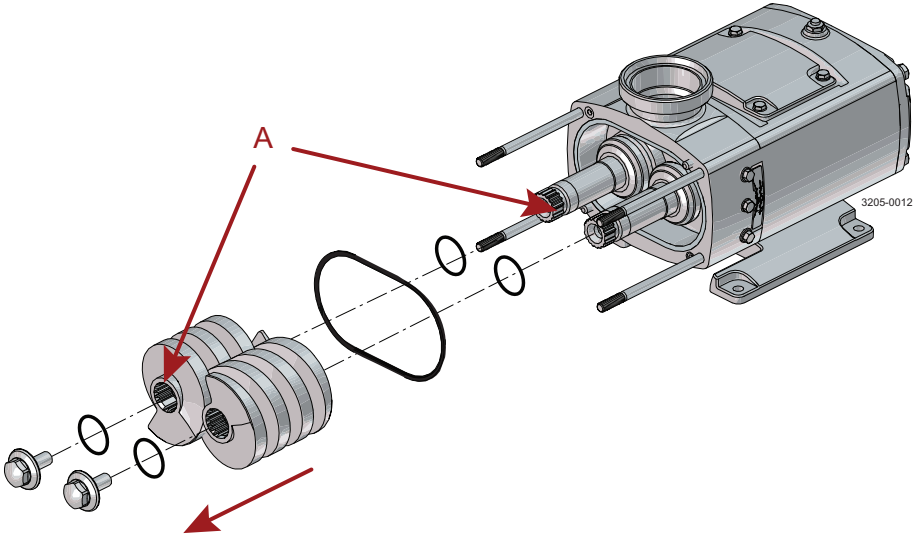

A) Identification Marks

5 Maintenance

Step 3

Removing primary seal components.

1. Remove seal retaining plugs, O-rings and gland guards.

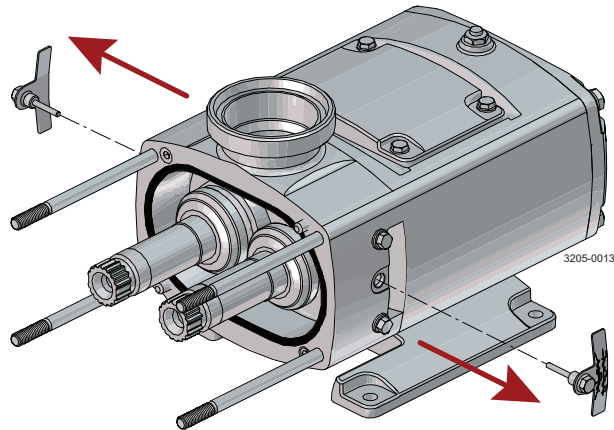

2. Gently ease cartridge seals from housing by levering against the gearcase and back of seal assembly if necessary.

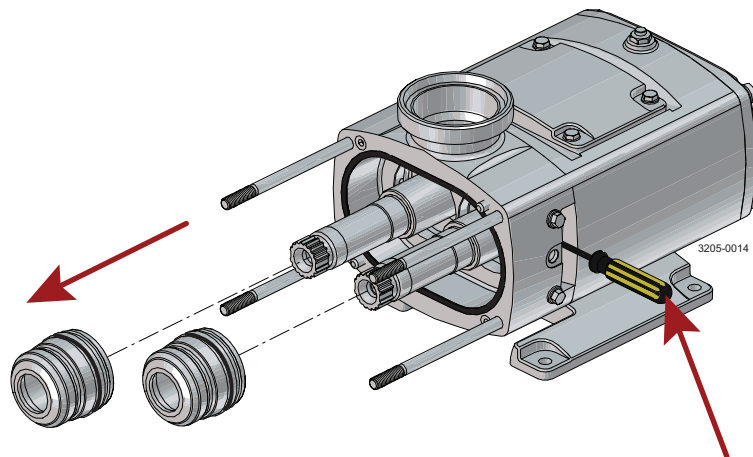

Step 4

Removing seal housing

1. Remove the seal housing retention screws.
2. Tap both sides of the seal housing with a soft mallet.
3. Withdraw the seal housing along the pump casing studs to remove.

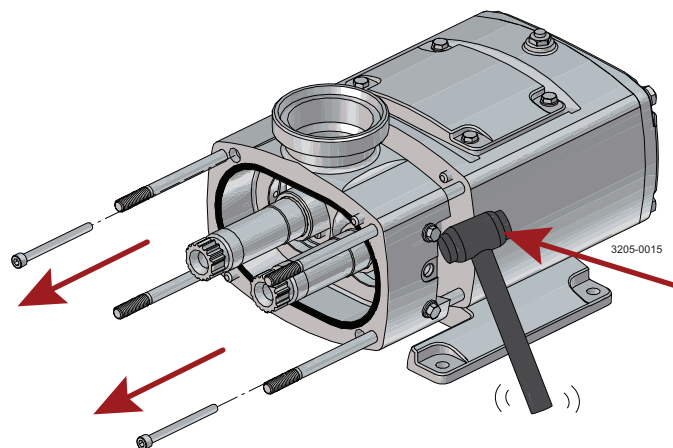

Step 5

Disassembling of gearbox

1. Remove pump casing studs.
2. Place a tray under the oil drain to collect the waste lubricant.
3. Remove the oil drain plug and seal and allow lubricant to drain.
4. Remove the gearbox end cover bolts and washers.
5. Pull out the whole axial bearing & shaft unit from the gearbox. To assist removal, tap shaft ends with a soft mallet.
6. Remove the gearbox O-ring. If this needs to be replaced.

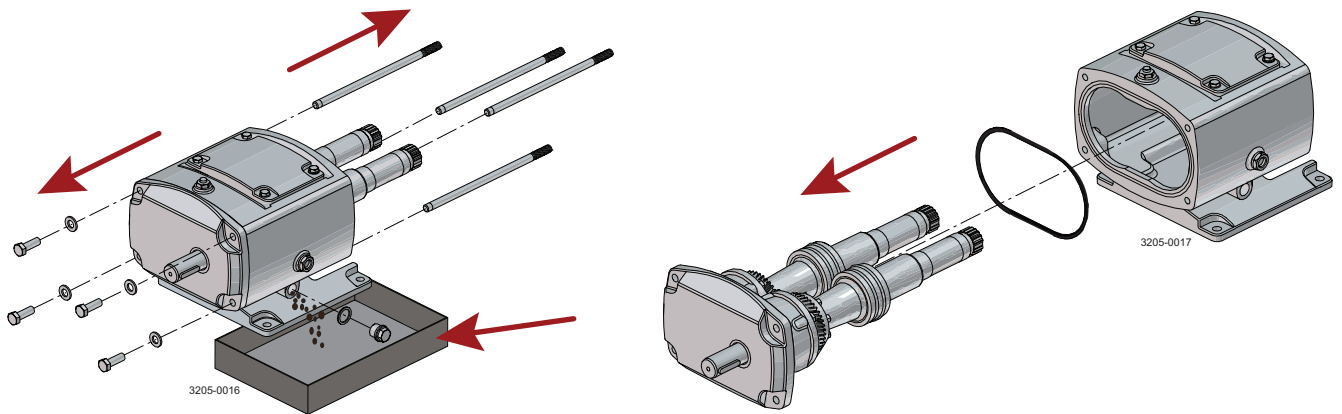

5 Maintenance

Step 6

Disassembling of front gearbox

1. Remove gear top cover bolts, washers, gear top cover and gear cover O-Ring.
2. Remove lip seals.
3. Remove needle bearing snap ring.
4. Tap the needle bearings outer races out of their seat..

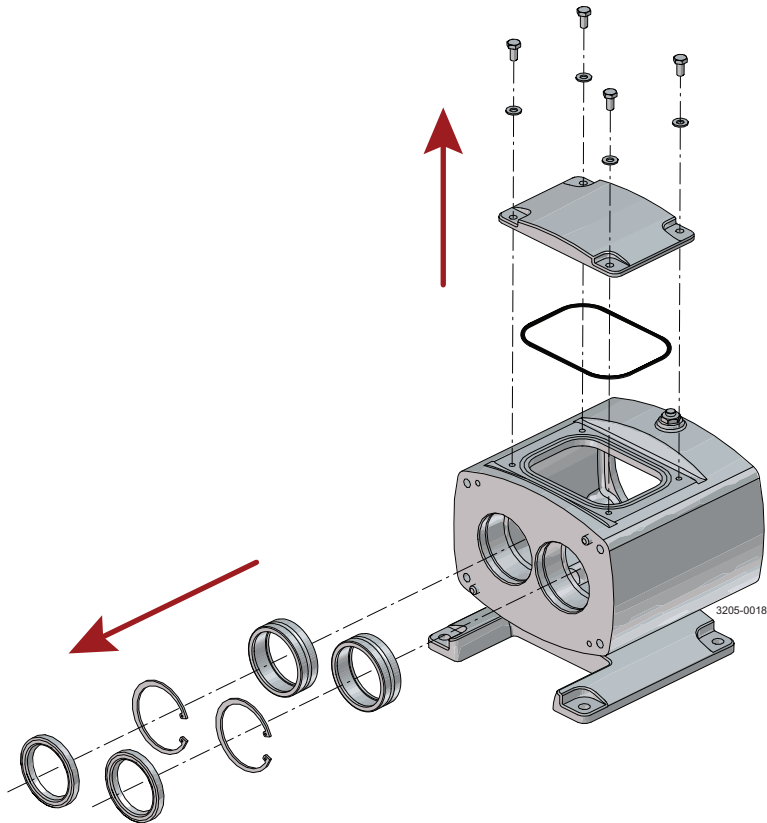

Step 7

Disassembling of bearing housing shaft assembly

1. Remove bearing retainer bolts and drive shaft key.
2. Pull out the complete shaft assembly.

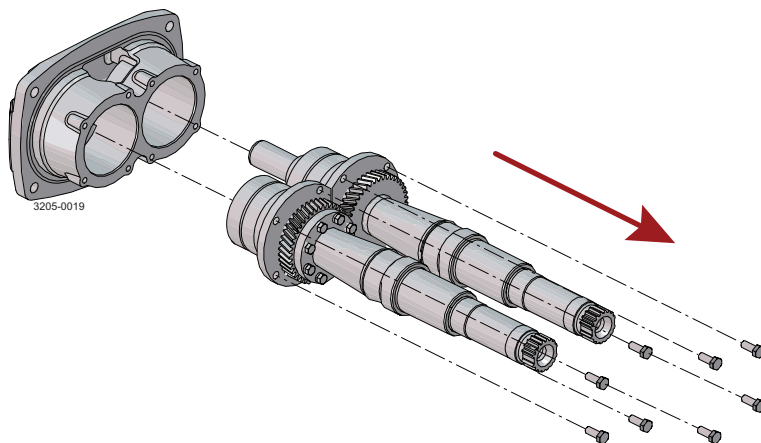

Step 8

Disassembling of shaft assembly

1. Fix the shaft assembly in a vice fitted with soft jaws taking care not to damage the shaft assembly.
2. Bend up locking tab on washer from bearing nut.
3. Loosen the bearing nut with a 'C' spanner by tapping sharply and remove it.

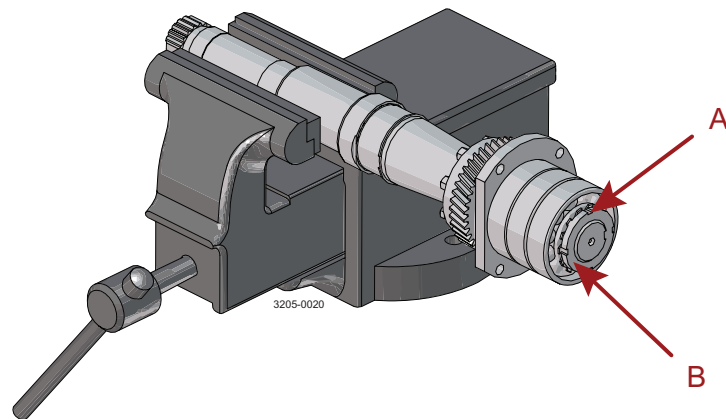

- A) Locking tab
B) Bearing nut
-

5 Maintenance

Step 9

Removing bearing and gear

1. Mount the shaft vertically in a press (splines pointing down) with a tool positively located against the gear and apply pressure to the top of the shaft so that the shaft passes through the bearings and gear.

CAUTION

2. Remove the needle bearing inner snap rings.
3. Mount the shaft vertically in a press splines pointing down with a tool positively located against the needle bearing inner race and apply pressure to the top of the shaft so that the shaft moves through the bearing.
4. Remove gear key from shaft.

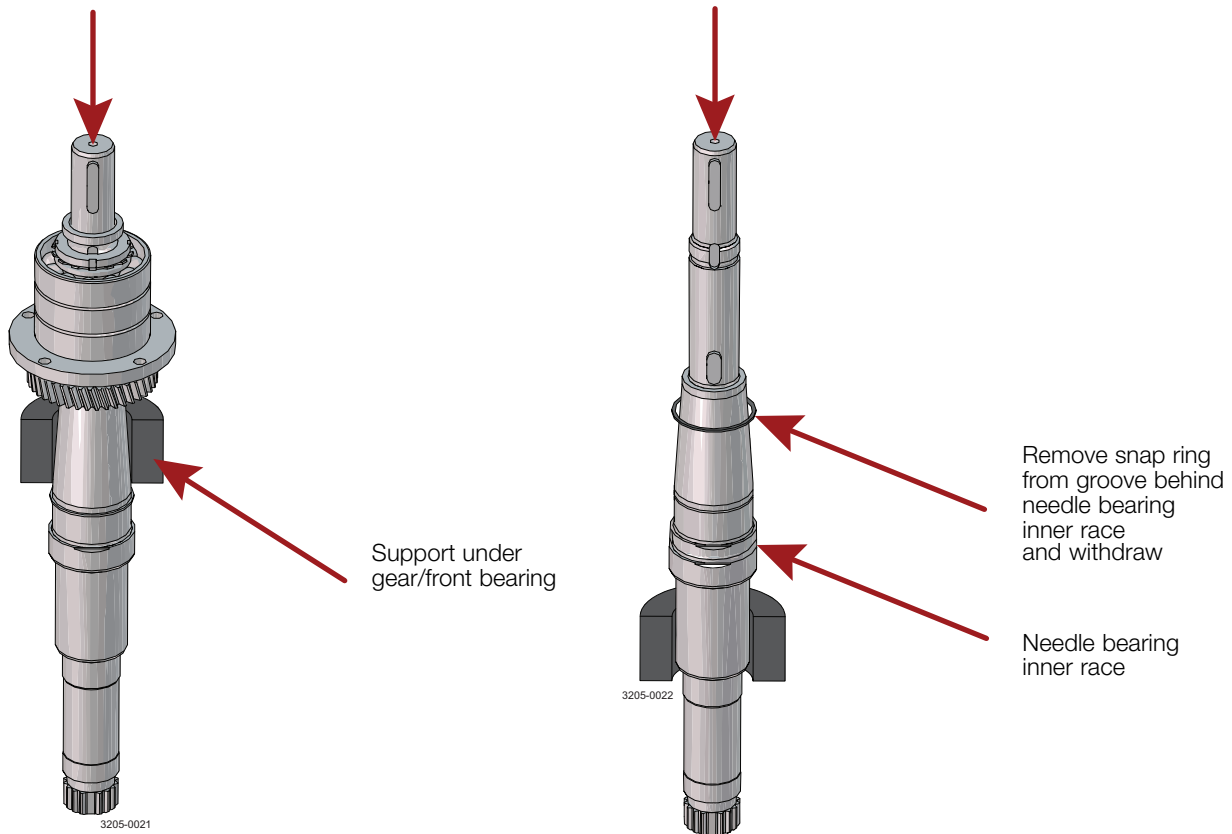

Step 10

Disassembly of adjustable timing gear

1. Remove timing gear assembly bolts and washers.
2. Remove timing gear clamping plate and timing gear from gear sleeve.

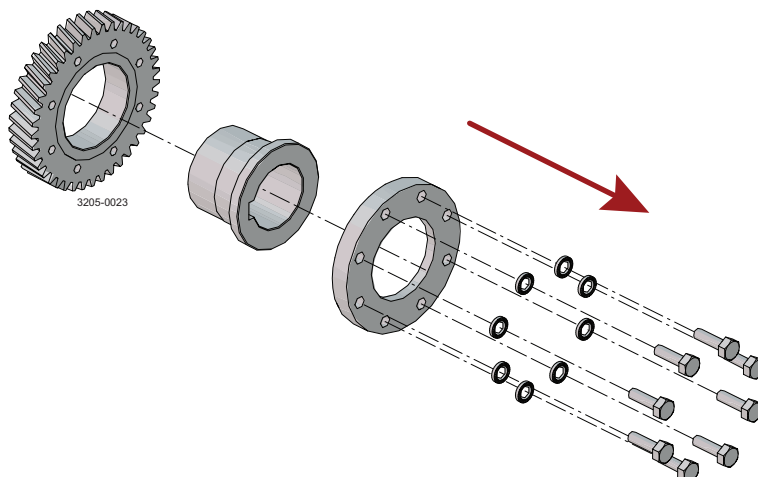

Step 11

Remove lip seal from gearbox end cover

1. Extract the lip seal from the gearbox end cover. It is essential to renew the lip seal prior to assembly.

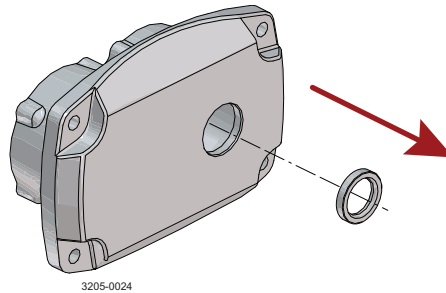

5 Maintenance

*Take care not to damage shaft surfaces, in particular where bearings and lipseals will be located
Ensure all fastenings are tightened to the torque settings as shown in Technical Data (See chapter 6 Technical data)*

5.4 Assembly

Step 1

Assembly of adjustable gear

1. Lubricate the inner diameter of the adjustable timing gear with oil.
2. Slide the timing gear onto the gear sleeve with the threads facing the collar.
3. Place the timing gear clamp plate from the other side and install the washers and gear sleeve bolts loosely.
4. Make sure the assembly rotates freely.

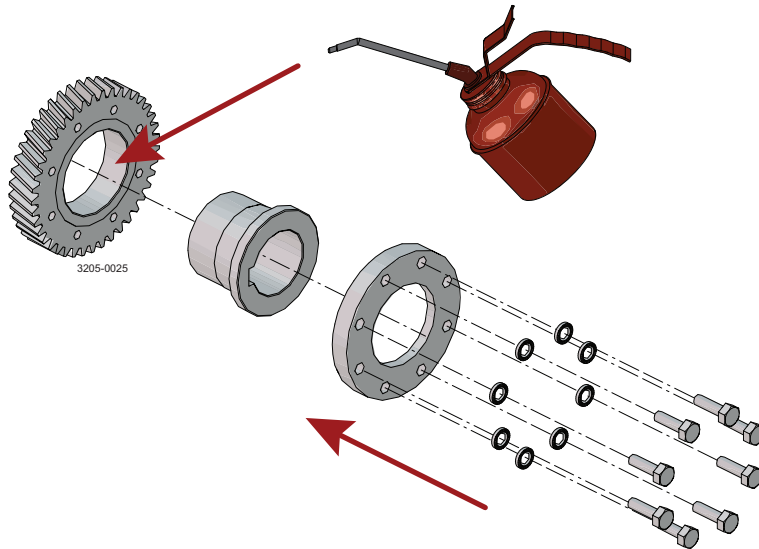

Take care not to damage shaft surfaces, in particular where bearings and lipseals will be located
 Ensure all fastenings are tightened to the torque settings as shown in Technical Data (See chapter 6 Technical data)

Step 2

Fitting bearings to shaft

1. Fix the shaft vertically in a vice fitted with soft jaws- taking care not to damage the shaft.
2. Heat needle bearing inner race up to 110°C (230°F) and shrink fit it onto its seat.
3. Mount needle bearing inner snap ring.
4. Fit gear key.
5. Apply an anti-seize compound to the bearing seat.
6. Slide gear over bearing seat until it sits against the shoulder.
7. Place bearing retainer loosely over shaft and gear.

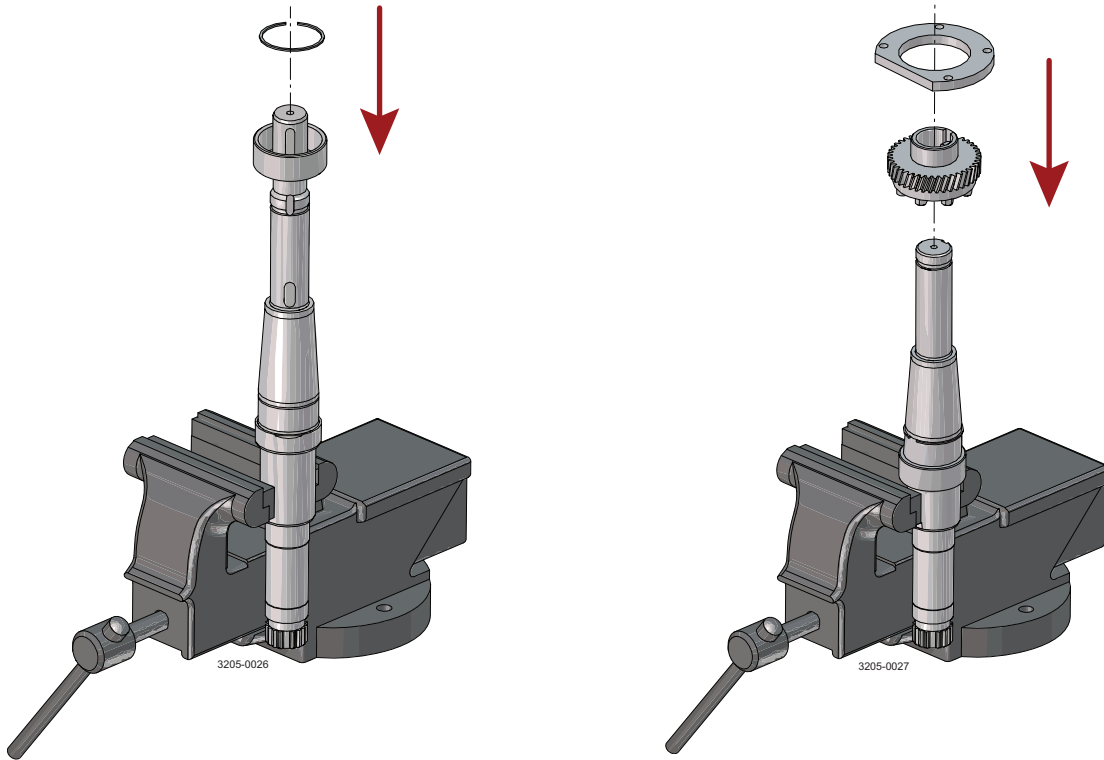

8. Heat the 3 angular contact ball bearings up to 110°C (230°F) and slide over the shaft.

Note: The bearing positioning is dependent on the suction and discharge direction. Two bearings face one direction and the third bearing faces the opposite direction.

CAUTION

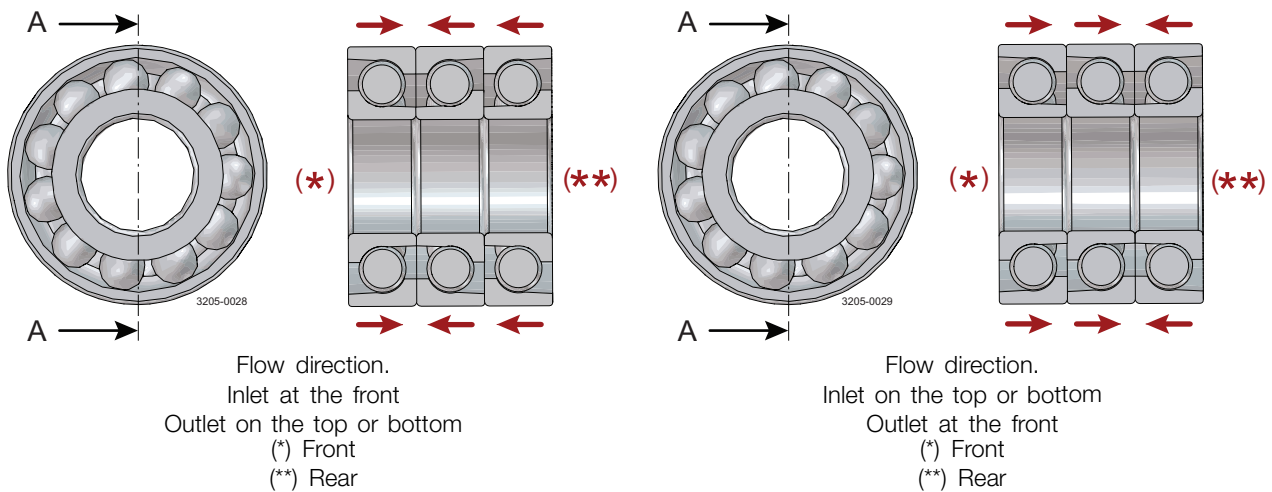

9. Place the tab washer in its position, make sure the inner tab is aligned in the shaft groove.
10. Apply an anti-seize compound to bearing nut and shaft thread.
11. Fit and tighten the bearing nut with a 'C' spanner by tapping sharply until one tab of the lock washer lines up with the bearing nut groove and fold the tab into the groove.

5 Maintenance

Take care not to damage shaft surfaces, in particular where bearings and lipseals will be located
Ensure all fastenings are tightened to the torque settings as shown in Technical Data (See chapter 6 Technical data)

Step 3

Install lip seal in gearbox end cover
1. Install lip seal in gearbox end cover.

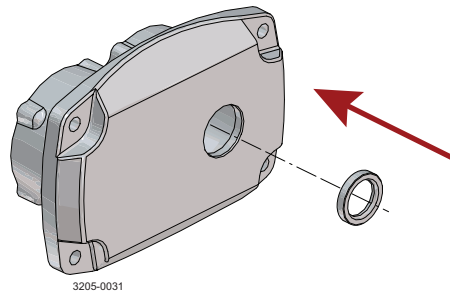

Step 4

Fitting shaft assembly in gearbox end cover. Ensure correct torques are used.

1. Slide drive and auxiliary shaft assembly in gearbox end cover (Take care not to damage the lip seal).
2. Apply a thread locking compound to the bearing retainer bolts.
3. Tighten the bearing retainer bolts to their recommended torque.

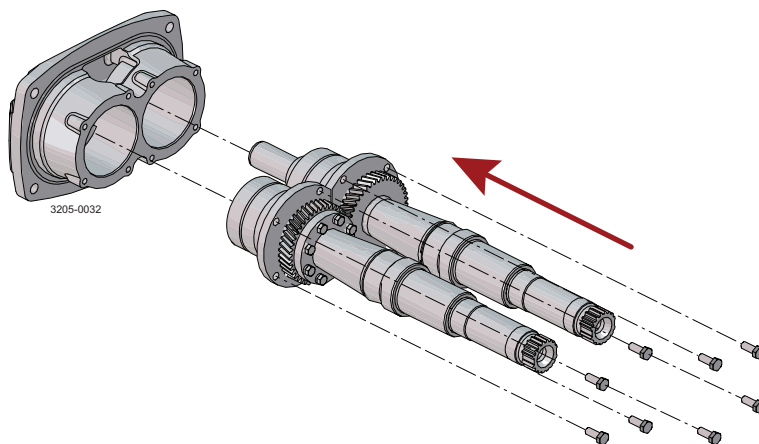

Take care not to damage shaft surfaces, in particular where bearings and lip seals will be located
Ensure all fastenings are tightened to the torque settings as shown in Technical Data (See chapter 6 Technical data)

Step 5

Assembling of gearbox. Ensure correct torques are used.

1. Tap the needle bearing outer races into their seat.
2. Fit needle bearing snap ring.
3. Fit lip seals.
4. Fit filler plug.
5. Fit oil sight glass.
6. Fit drain plug and washer.

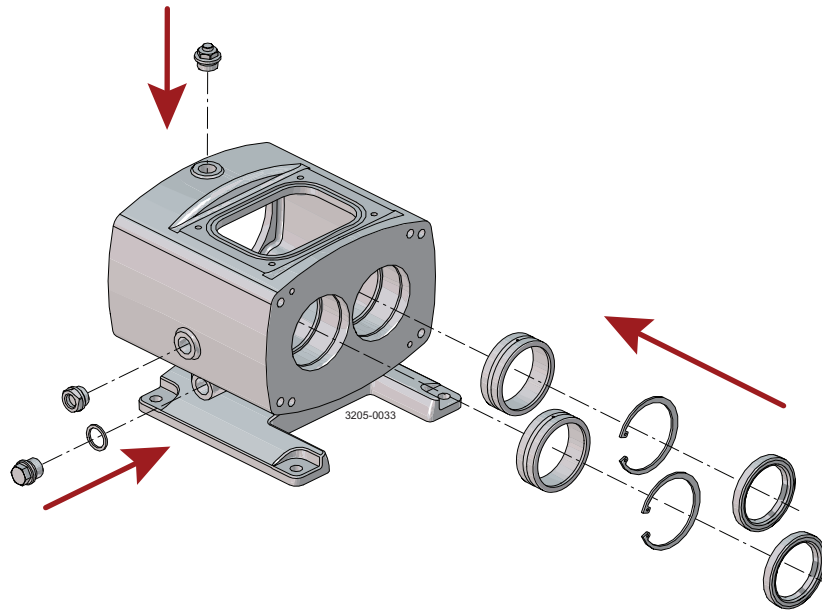

Step 6

Assembling of gearbox. Ensure correct torques are used.

1. Fit gearbox O-Ring use grease to keep it in place.
2. Push in the shaft assembly into the front gearbox. (take care not to damage the lip seals). Ensure that the drive shaft is in the correct position to realign with the motor coupling.
3. Fit the gearbox end cover bolts and washers and torque them to their recommended value.
4. Fit drive shaft key.

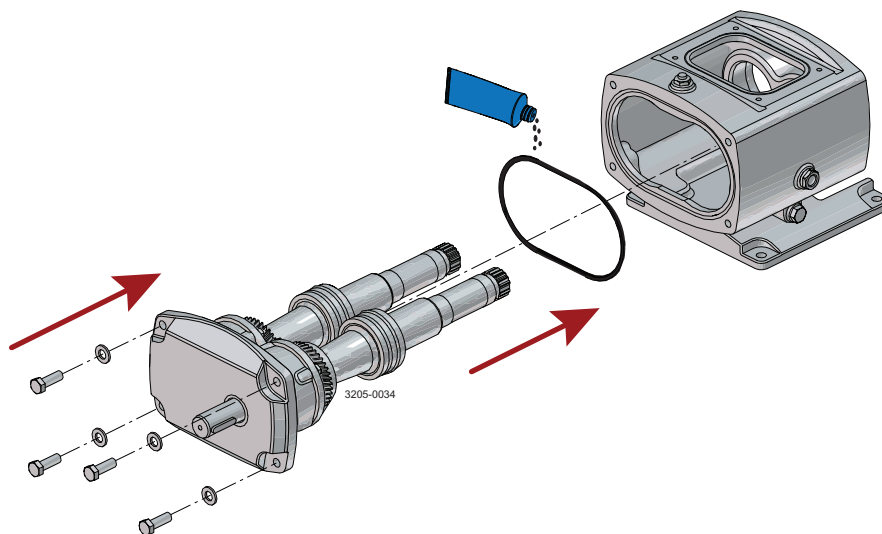

5 Maintenance

Take care not to damage shaft surfaces, in particular where bearings and lipseals will be located
Ensure all fastenings are tightened to the torque settings as shown in Technical Data (See chapter 6 Technical data)

Step 7

Install seal housing. Ensure correct torques are used.

1. Fit the pump casing studs and dowel pins to the gearbox.
2. Fit dowel pins in seal housing.
3. Slide seal housing on the pump casing studs and push back locating onto the dowels. (Make sure the port connection is in the correct orientation).
4. Install the seal housing retention screws and tighten them.

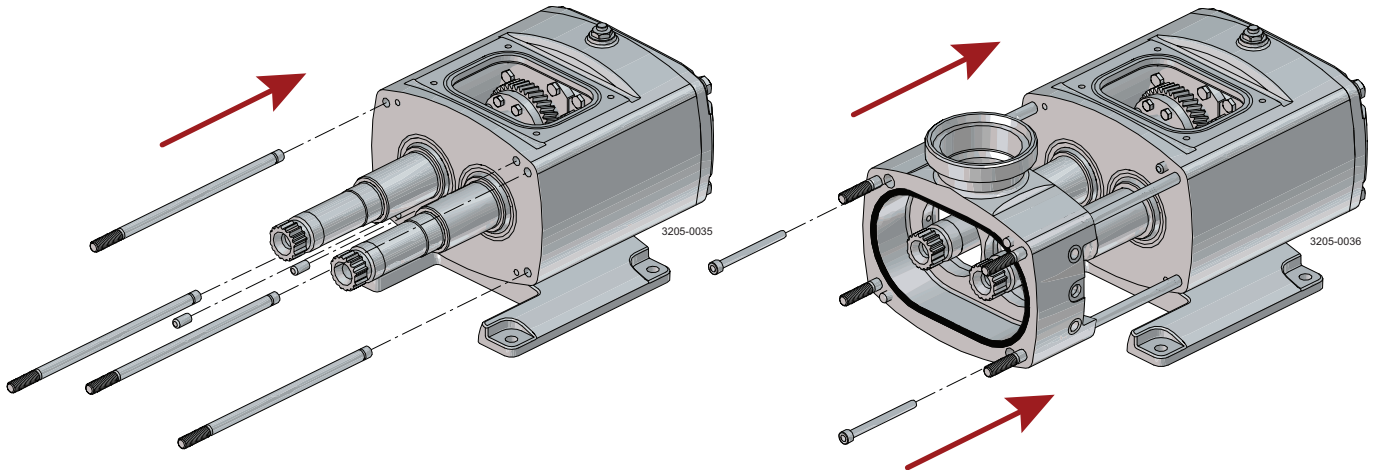

Step 8

Installing primary seal components. Ensure correct torques are used.

1. Lubricate external elastomers.
2. Slide cartridge seal over shaft ensuring that the seal drive flat (OS2x/OS3x/OS4x) or seal drive lug (OS1x) aligns with the corresponding flat (OS2x/OS3x/OS4x) or cut-out (OS1x) in the seal housing. Press fully home into the seal housing and abutment shoulder.
3. Fit seal retention plug, pin, O-ring and gland guard.
4. Fit seal flushing fittings or plug and washers for single unflushed seals.

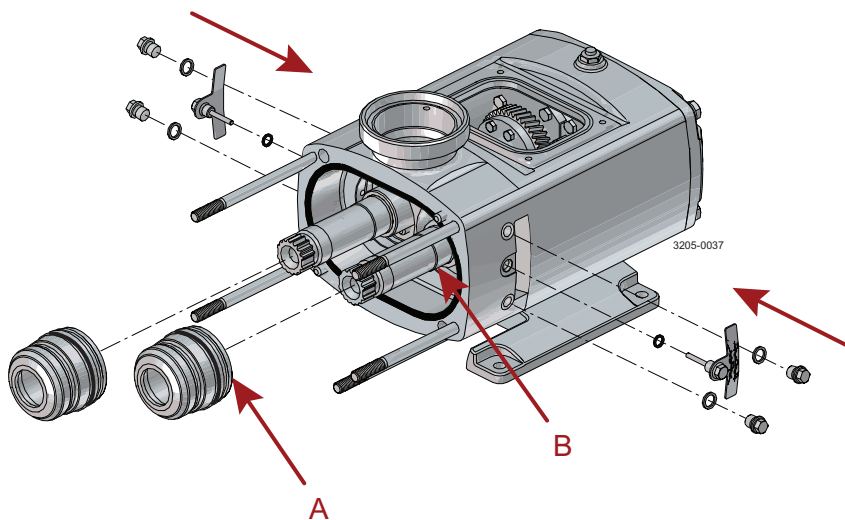

- A) Seal drive flat
B) Abutment shoulder

Take care not to damage shaft surfaces, in particular where bearings and lipseals will be located
Ensure all fastenings are tightened to the torque settings as shown in Technical Data (See chapter 6 Technical data)

Step 9

Fitting feed screws. Ensure correct torques are used.

1. Place the feed screws on a flat surface and mesh them so that the ends are flush. Ensure that the screws are the correct way around and the identification marks correspond with the markings on the shafts.
2. Fit both feed screws onto the shafts simultaneously and push them till they make contact with the mechanical seal sleeve. (To make the splines fit you may need to rotate the shafts until they match).
3. Apply a locking compound to the feed screw nut thread.
4. Fit elastomer onto feed screw nut and lubricate it.
5. Insert a plastic/wooden block between the feed screw run outs to stop them from turning.
6. Tighten fluid screw nuts.

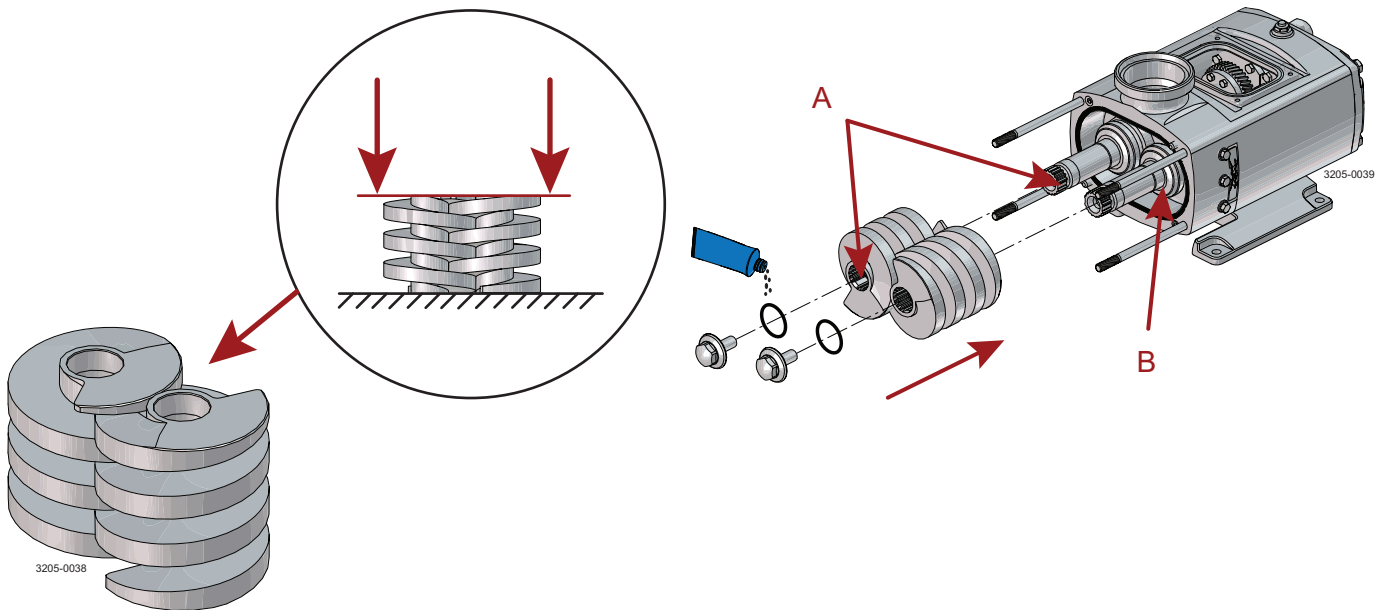

A) Identification marks

B) Ensure that the elastomers are fitted to the front of the cartridge seals before fitting the feed screws

5 Maintenance

*Take care not to damage shaft surfaces, in particular where bearings and lipseals will be located
Ensure all fastenings are tightened to the torque settings as shown in Technical Data (See chapter 6 Technical data)*

Step 10

Setting feed screw timing. Ensure correct torques are used.

1. Make sure the gear sleeve bolts are loose, and the gear rotates on the sleeve.
2. Turn the drive shaft and check the clearance between the feed screw flanks. Use feeler gauges to make sure the clearance is evenly divided between the flanks. Refer to Pump head clearance Information (6.2 Pumphead Clearance information).
3. Tighten the gear sleeve bolts in a cross pattern.
4. Re-check the timing and ensure it is within specification (6.2 Pumphead Clearance information).

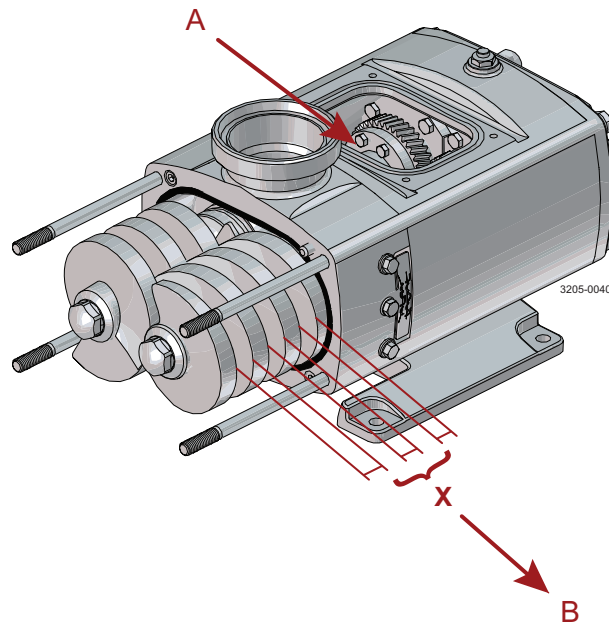

A) Timing gear bolts

B) Ensure that the clearance is equal between all mesh points between the flanks

Take care not to damage shaft surfaces, in particular where bearings and lipseals will be located
Ensure all fastenings are tightened to the torque settings as shown in Technical Data (See chapter 6 Technical data)

Step 11

Fitting pump casing and front cover. Ensure correct torques are used.

1. Fit the pump casing elastomer in seal housing and front cover.
2. Fit pump casing over feed screws and engage with dowels (Attention, ensure the housing is in the same orientation as it was before it was removed).
3. Fit dowels in front cover.
4. Fit front cover to pump casing.
5. Fit front cover nuts, washers and torque them to their recommended value.

NOTE: If a new pump casing is being fitted or if the pump is being modified due to reversed flow direction the orientation of the pump casing should be:

Shaft Rotation Clockwise (viewed from rear of the pump)

Front Inlet / Top Outlet: - Markings on the front face, Top

Top Inlet / Front Outlet: - Markings on the front face, Bottom

Shaft Rotation Anti-Clockwise (viewed from rear of the pump)

Front Inlet / Top Outlet: - Markings on the front face, Bottom

Top Inlet / Front Outlet: - Markings on the front face, Top

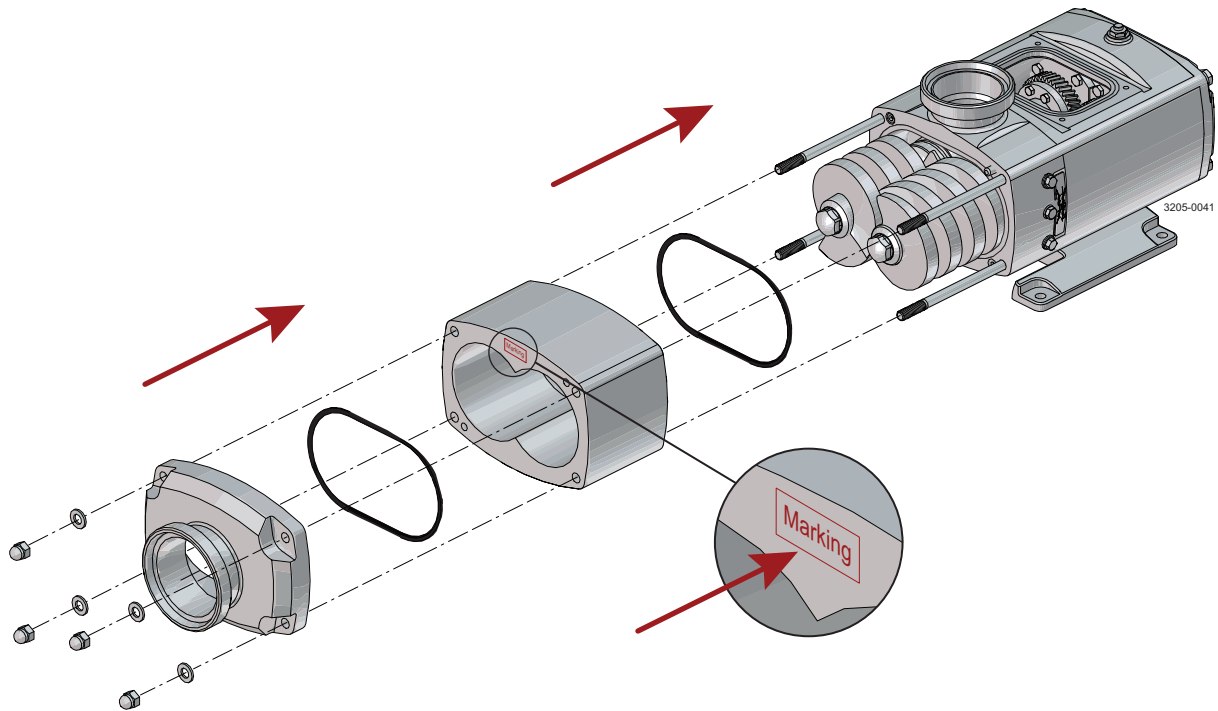

Step 12

Function test

1. Rotate drive shaft clockwise to check for jamming.

5 Maintenance

*Take care not to damage shaft surfaces, in particular where bearings and lipseals will be located
Ensure all fastenings are tightened to the torque settings as shown in Technical Data (See chapter 6 Technical data)*

Step 13

Adding lubricant

1. Pour the recommended oil lubricant into the gear top cover opening. (See section 6 Technical data for correct oil quality.)
2. Fit gear top cover.
3. Fit the gear top cover and fix it with bolts and washers.

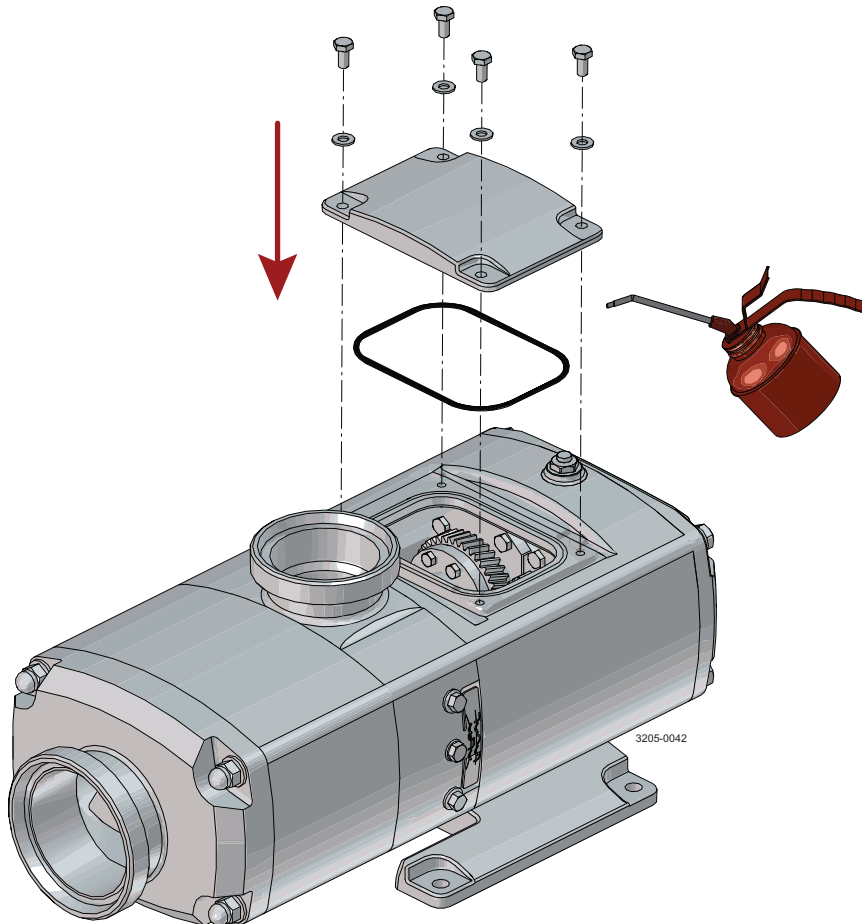

Take care not to damage shaft surfaces, in particular where bearings and lipseals will be located
 Ensure all fastenings are tightened to the torque settings as shown in Technical Data (See chapter 6 Technical data)

5.5 Maintenance seals - Single Seal - All Models

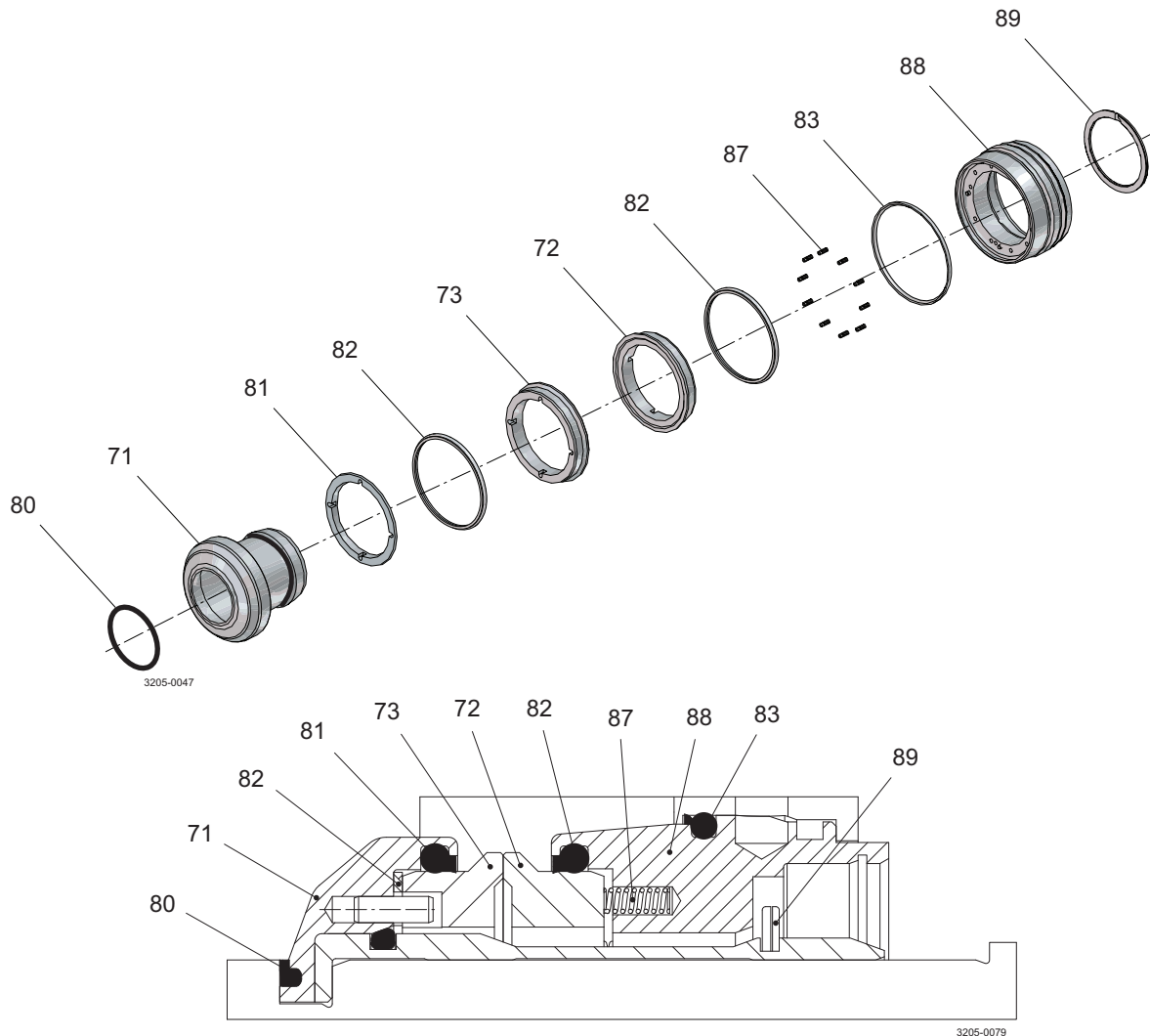

Assembly

Check that all parts are accounted for and ensure no parts are damaged. Seal faces are brittle, and care must be taken not to chip these components during fitting of the seal. Ensure seal faces are clean throughout the fitment. If a need to be cleaned, use acetone or similar solvent sprayed onto lint free tissue.

Equipment to be used: Acetone, compatible lubricant and lint free tissues

Step 1

Lightly lubricate screw clamping profile elastomer (80) with suitable lubricant compatible with the application and fit to the rotary holder (71).

Step 2

Place plastic washer (81) in rotary holder (71) aligning the slots in the washer (81) with the pins fitted in the rotary holder bore (71).

Step 3

Lightly lubricate elastomer (82) with suitable lubricant and fit into rotary holder (71) groove.

5 Maintenance

*Take care not to damage shaft surfaces, in particular where bearings and lipseals will be located
Ensure all fastenings are tightened to the torque settings as shown in Technical Data (See chapter 6 Technical data)*

Step 4

Align the slots in the rotary face (73) with the pins fitted in the rotary holder bore (71), then firmly press the rotary face (73) fully home into the rotary holder bore (71).

Step 5

Lightly lubricate the static face profile elastomer (82) with suitable lubricant compatible with the application and fit into seal housing (88) groove.

Step 6

Lightly lubricate the seal housing profile elastomer (83) with suitable lubricant compatible with the application and fit onto the seal housing (88).

Step 7

Drop coil springs (87) into coil spring holes in the seal housing (88).

Step 8

Align the slots in the static face (72) with the pins fitted in the seal housing (88), then firmly press the static face (72) fully home into seal housing bore (88).

Step 9

Spray acetone or similar solvent onto lint free tissue and wipe the sealing surfaces of the rotary face (73) and static face (72) clean. NOTE: Do not spray acetone directly onto the sealing surfaces.

Step 10

Turn the rotary assembly upside down and slide the sleeve carefully into the static assembly mating the sealing surfaces together.

Step 11

Turn the complete seal around whilst holding it together.

Step 12

Press the seal housing (88) down whilst fitting the circlip (89) into the groove in the seal housing (88).

Step 13

Validate the assembly by compressing the seal a few times, making sure it springs back out each time.

Carefully fit the mechanical seal onto the shaft and into the pump housing making sure the flat of the seal housing aligns with the flat in the pump housing and fit seal retaining screw and gland guard.

CHECK SCREW CLEARANCES AND RETIME PUMP IF NECESSARY

Disassembly

Disassembly of the mechanical seal is the reverse procedure of assembly, as above.

Take care not to damage shaft surfaces, in particular where bearings and lipseals will be located
 Ensure all fastenings are tightened to the torque settings as shown in Technical Data (See chapter 6 Technical data)

5.6 Single Flushed Seal - All Models

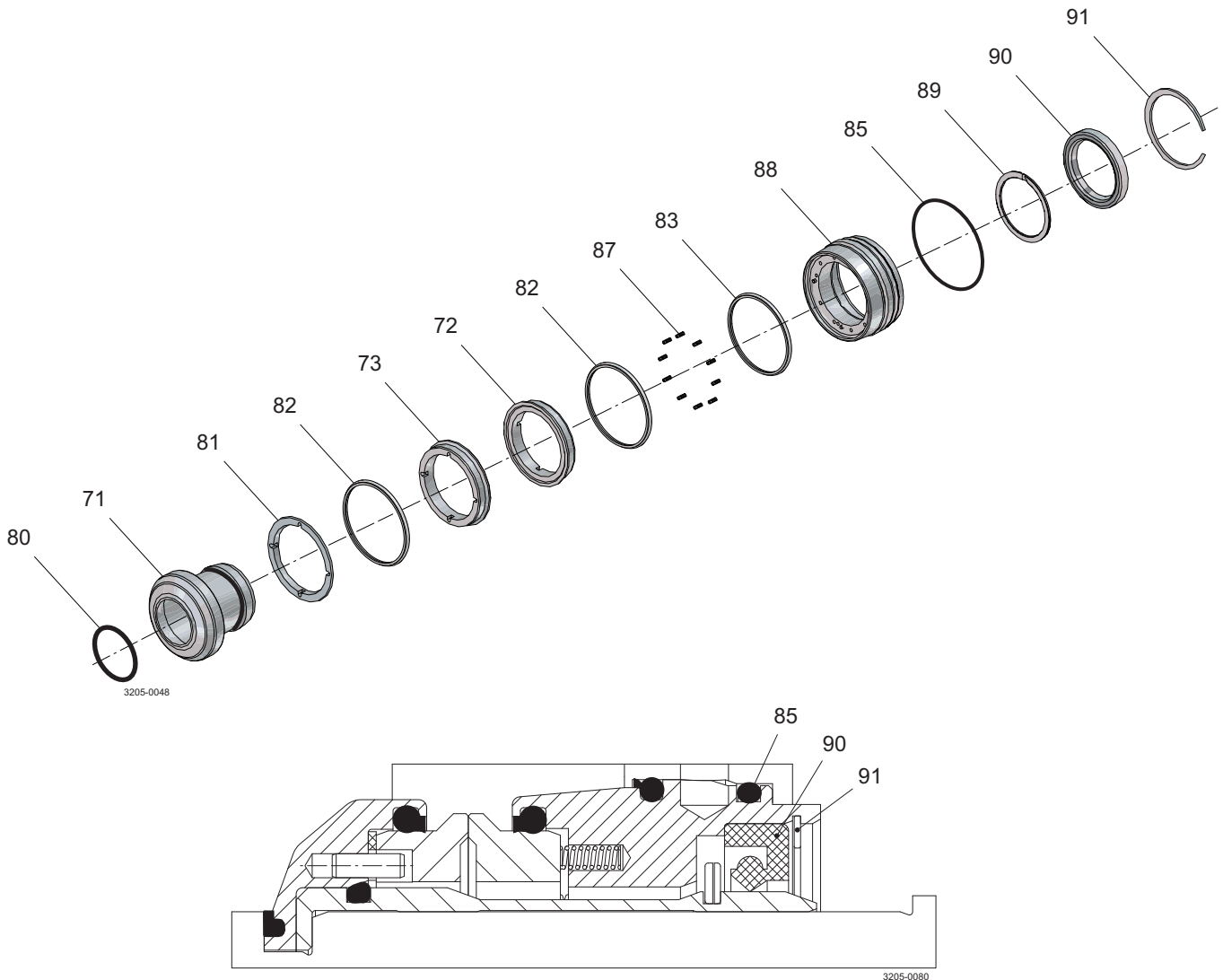

Assembly

Check that all parts are accounted for and ensure no parts are damaged. Seal faces are brittle, and care must be taken not to chip these components during fitting of the seal. Ensure seal faces are clean throughout the fitment. If a need to be cleaned, use acetone or similar solvent sprayed onto lint free tissue.

Equipment to be used: Acetone, compatible lubricant and lint free tissues

Step 1

Lightly lubricate screw clamping profile elastomer (80) with suitable lubricant compatible with the application and fit to the rotary holder (71).

Step 2

Place plastic washer (82) in rotary holder (71) aligning the slots in the washer (82) with the pins fitted in the rotary holder bore (71).

Step 3

Lightly lubricate elastomer (82) with suitable lubricant and fit into rotary holder (71) groove.

5 Maintenance

*Take care not to damage shaft surfaces, in particular where bearings and lipseals will be located
Ensure all fastenings are tightened to the torque settings as shown in Technical Data (See chapter 6 Technical data)*

Step 4

Align the slots in the rotary face (73) with the pins fitted in the rotary holder bore (71), then firmly press the rotary face (73) fully home into the rotary holder bore (71).

Step 5

Lightly lubricate the static face profile elastomer (82) with suitable lubricant compatible with the application and fit into seal housing (88) groove.

Step 6

Lightly lubricate the seal housing profile elastomer (83) with suitable lubricant compatible with the application and fit onto the seal housing (88).

Step 7

Drop coil springs (87) into coil spring holes in the seal housing (88).

Step 8

Align the slots in the static face (72) with the pins fitted in the seal housing (88), then firmly press the static face (72) fully home into housing bore (88).

Step 9

Spray acetone or similar solvent onto lint free tissue and wipe the sealing surfaces of the rotary face (73) and static face (72) clean. **NOTE:** Do not spray acetone directly onto the sealing surfaces.

Step 10

Turn the rotary assembly upside down and slide the sleeve carefully into the static assembly mating the sealing surfaces together.

Step 11

Turn the complete seal around whilst holding it together.

Step 12

Press the seal housing (88) down whilst fitting the circlip (89) into the groove in the seal housing (88).

Step 13

Lightly lubricate O-ring (85) and fit onto the seal housing (88).

Step 14

Lightly lubricate outside diameter of lip seal (90).

Step 15

Firmly press the lip seal (90) fully home into the housing bore (88).

Step 16

Fit circlip (91) into the groove in the seal housing (88).

Step 17

Validate the assembly by compressing the seal a few times, making sure it springs back out each time.
Carefully fit the mechanical seal onto the shaft and into the pump housing making sure the flat of the seal housing aligns with the flat in the pump housing and fit seal retaining screw and gland guard.

CHECK SCREW CLEARANCES AND RETIME PUMP IF NECESSARY

Disassembly

Disassembly of the mechanical seal is the reverse procedure of assembly, as above.

Take care not to damage shaft surfaces, in particular where bearings and lipseals will be located
 Ensure all fastenings are tightened to the torque settings as shown in Technical Data (See chapter 6 Technical data)

5.7 Double Seal OS1x

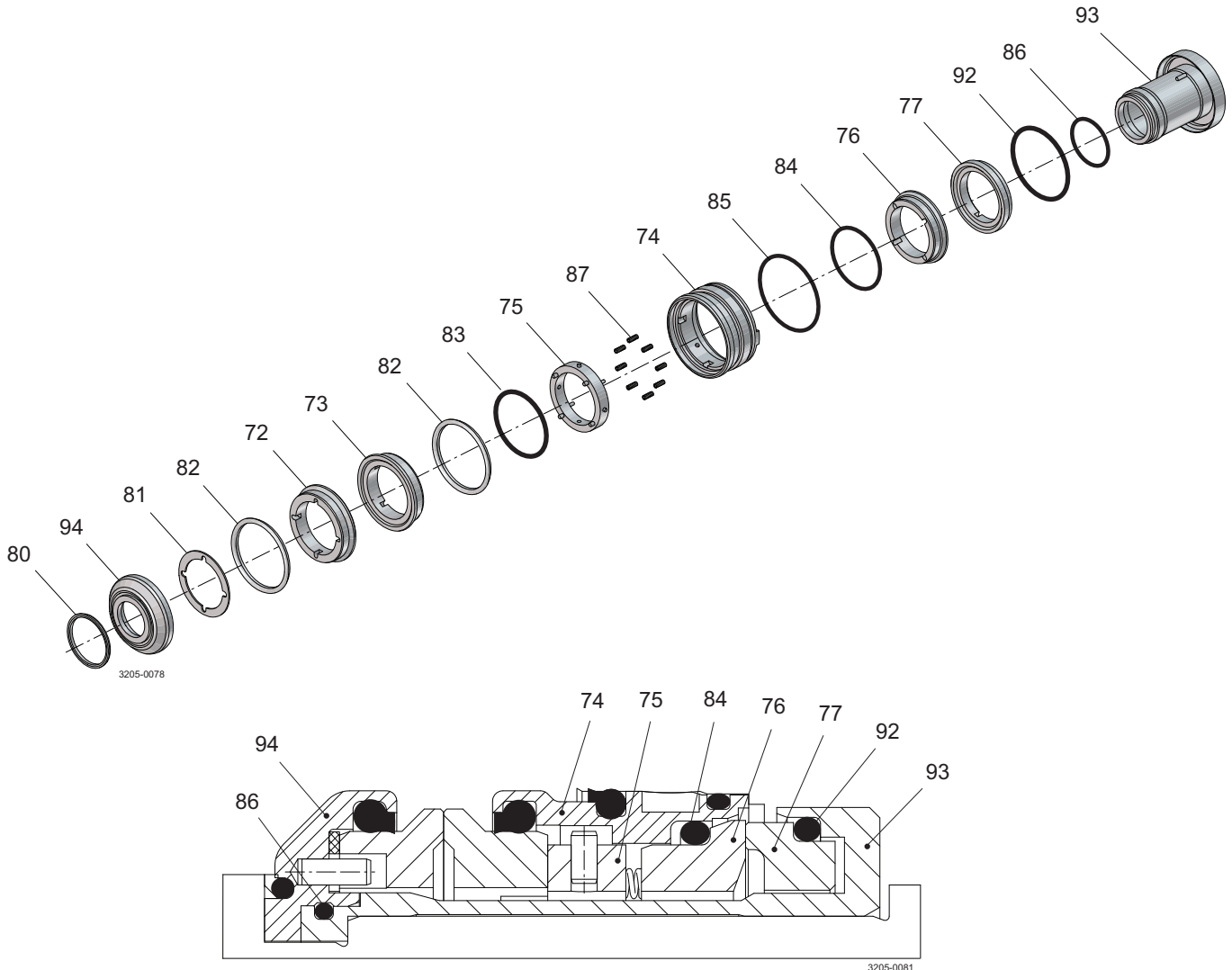

Assembly

Check that all parts are accounted for and ensure no parts are damaged. Seal faces are brittle, and care must be taken not to chip these components during fitting of the seal. Ensure seal faces are clean throughout the fitment. If a need to be cleaned, use acetone or similar solvent sprayed onto lint free tissue.

Equipment to be used: Acetone, compatible lubricant and lint free tissues.

Step 1

Lightly lubricate O-ring (86) and fit to the Shaft sleeve (93).

Step 2

Lightly lubricate O-ring (92) and fit to the rotary face (77).

Step 3

Align the slots in the rotary face (77) with the pins fitted in the shaft sleeve (93), then firmly press the rotary face (77) fully home into the shaft sleeve bore (94).

5 Maintenance

*Take care not to damage shaft surfaces, in particular where bearings and lipseals will be located
Ensure all fastenings are tightened to the torque settings as shown in Technical Data (See chapter 6 Technical data)*

Step 4

Lightly lubricate the seal housing profile elastomer (83) and fit onto the seal housing (74).

Step 5

Lightly lubricate O-ring (85) and fit onto the seal housing (74).

Step 6

Align radial pins in drive ring (75) with the anti-rotation slots in seal housing (74). Fit drive ring (75) into housing (74) making sure the coil springs holes in the drive ring (75) are facing inwards.

Step 7

Lightly lubricate the static face profile elastomer (82) and fit into seal housing (74) groove.

Step 8

Align two of the slots in the static face (73) with the axial pins fitted in the drive ring (75), then firmly press the static face (73) fully home into the seal housing bore (74).

Step 9

Gently turn the static unit around, and let it rest on the static face sealing surface (73) on a clean soft lint free tissue.

Step 10

Drop coil springs (87) into coil spring holes in the drive ring (75).

Step 11

Lightly lubricate O-ring (84) and fit onto the static face (76).

Step 12

Align the slots in the static face (76) with the axial pins fitted in the drive ring (75), then firmly press the static face (76) down fully home into the seal housing bore (74).

Step 13

Spray acetone or similar solvent onto lint free tissue and wipe the sealing surfaces of the rotary face (77) and static face (76) clean.

NOTE: Do not spray acetone directly onto the sealing surfaces.

Step 14

Pick seal housing (74) assembly up and whilst holding the assembly compressed, turn it around and slide over shaft sleeve (93) mating the rotary face (77) and static face (76).

Step 15

Lightly lubricate screw clamping profile elastomer (80) and fit to the rotary holder (94).

Step 16

Place plastic washer (81) in rotary holder (78) aligning the slots in the washer (81) with the pins fitted in the rotary holder bore (94).

Step 17

Lightly lubricate the rotary face profile elastomer (82) and fit to the rotary holder (94) groove.

Step 18

Align the slots in the rotary face (72) with the pins fitted in the rotary holder bore (94), then firmly press the rotary face (72) fully home into the rotary holder bore (94).

Step 19

Spray acetone or similar solvent onto lint free tissue and wipe the sealing surfaces of the rotary face (72) and static face (73) clean.

NOTE: Do not spray acetone directly onto the sealing surfaces.

Step 20

Firmly press rotary holder (94) onto the shaft sleeve (93), mating the rotary face (72) and static face (73).

*Take care not to damage shaft surfaces, in particular where bearings and lipseals will be located
Ensure all fastenings are tightened to the torque settings as shown in Technical Data (See chapter 6 Technical data)*

Step 21

Validate the assembly by compressing the seal a few times, making sure it springs back out each time.

Carefully fit the mechanical seal onto the shaft and into the pump housing making sure the lug of the seal housing aligns with the slot in the pump housing and fit seal retaining screw and gland guard.

CHECK SCREW CLEARANCES AND RETIME PUMP IF NECESSARY

Disassembly

Disassembly of the mechanical seal is the reverse procedure of assembly, as above.

5 Maintenance

Take care not to damage shaft surfaces, in particular where bearings and lipseals will be located
Ensure all fastenings are tightened to the torque settings as shown in Technical Data (See chapter 6 Technical data)

5.8 Double Seal OS2x, OS3x, OS4x

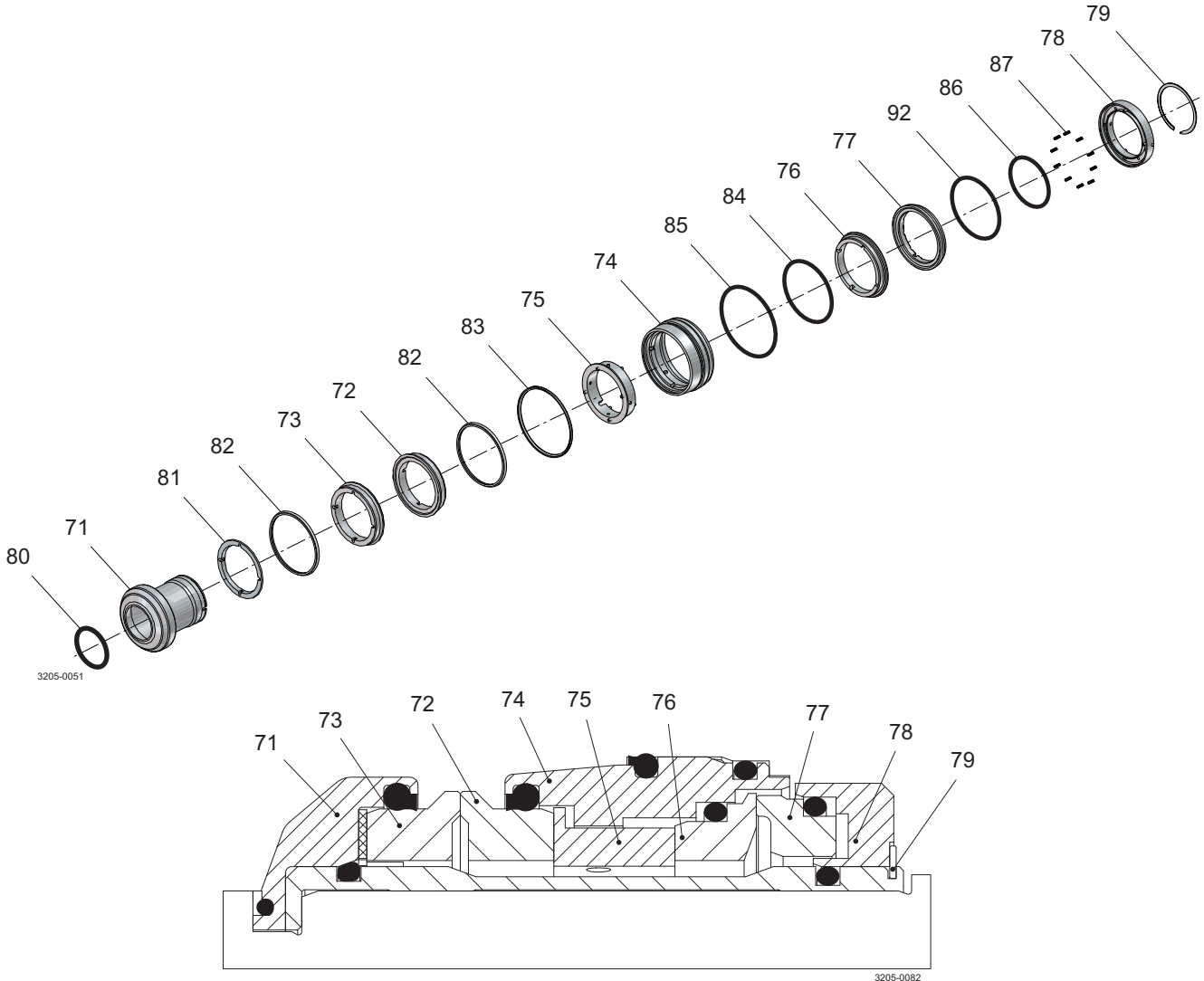

Assembly

Check that all parts are accounted for and ensure no parts are damaged. Seal faces are brittle, and care must be taken not to chip these components during fitting of the seal. Ensure seal faces are clean throughout the fitment. If a need to be cleaned, use acetone or similar solvent sprayed onto lint free tissue.

Equipment to be used: Acetone, compatible lubricant and lint free tissues.

Step 1

Lightly lubricate screw clamping profile elastomer (80) with suitable lubricant compatible with the application and fit to the rotary holder (71).

Step 2

Place plastic washer (82) in rotary holder (71) aligning the slots in the washer (82) with the pins fitted in the rotary holder bore (71).

Step 3

Lightly lubricate elastomer (82) with suitable lubricant and fit into rotary holder (71) groove.

*Take care not to damage shaft surfaces, in particular where bearings and lipseals will be located
Ensure all fastenings are tightened to the torque settings as shown in Technical Data (See chapter 6 Technical data)*

Step 4

Align the slots in the rotary face (73) with the pins fitted in the rotary holder bore (71), then firmly press the rotary face (73) fully home into the rotary holder bore (71).

Step 5

Lightly lubricate O-ring (86) and fit onto the rotary holder (71).

Step 6

Lightly lubricate the seal housing profile elastomer (83) with suitable lubricant compatible with the application and fit onto the seal housing (74).

Step 7

Lightly lubricate O-ring (85) and fit onto the seal housing (74).

Step 8

Lightly lubricate O-ring (84) and fit into the seal housing bore (74).

Step 9

Align radial pins in drive ring (75) with the anti-rotation slots in seal housing (74) and the slots in the drive ring (75) with the flush holes in the seal housing (74). Fit drive ring (75) into housing (74).

Step 10

Firmly press down static face (76) into the seal housing (74) while aligning the slots with the axial pins in the drive ring (75).

Step 11

Lightly lubricate the static face profile elastomer (82) with suitable lubricant compatible with the application and fit into seal housing (74) groove.

Step 12

Align the slots in the static face (72) with the axial pins fitted in the drive ring (75), then firmly press the static face (72) fully home into the seal housing bore (71).

Step 13

Drop coil springs (87) into coil spring holes in the drive ring (78).

Step 14

Lightly lubricate O-ring (92) and fit onto the rotary face (77).

Step 15

Gently place rotary face (77) onto the coil springs (87) while aligning the pin-slots with the pins in the drive ring (78). Make sure all coil springs sit firmly in all coil spring holes.

Step 16

Spray acetone or similar solvent onto lint free tissue and wipe the sealing surfaces of the rotary faces (73)(77) and static faces (72)(76) clean.

NOTE: Do not spray acetone directly onto the sealing surfaces.

Step 17

Place housing assembly on top of drive ring (78), mating static face (76) with rotary face (77).

Step 18

Pick assembly up and whilst holding the assembly compressed, turn it around and slide over sleeve assembly mating the rotary face (73) and static face (72).

Step 19

Press the drive ring (78) down whilst fitting the circlip (79) into the groove in the seal housing (74).

5 Maintenance

*Take care not to damage shaft surfaces, in particular where bearings and lipseals will be located
Ensure all fastenings are tightened to the torque settings as shown in Technical Data (See chapter 6 Technical data)*

Step 20

Validate the assembly by compressing the seal a few times, making sure it springs back out each time.
Carefully fit the mechanical seal onto the shaft and into the pump housing making sure the flat of the seal housing aligns with the flat in the pump housing and fit seal retaining screw and gland guard.

CHECK SCREW CLEARANCES AND RETIME PUMP IF NECESSARY

Disassembly

Disassembly of the mechanical seal is the reverse procedure of assembly, as above.

Take care not to damage shaft surfaces, in particular where bearings and lipseals will be located
 Ensure all fastenings are tightened to the torque settings as shown in Technical Data (See chapter 6 Technical data)

5.9 Heating (option)

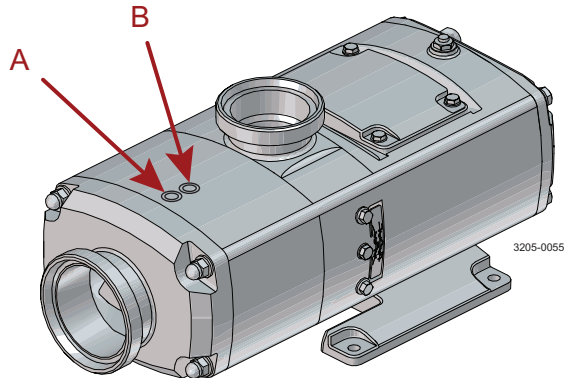

- A) Outlet
- B) Link Pipe

Ensure the pump is connected to the heating supply in the correct way.
 Refer to connection size for pump models in the table.

Heating Connections	Size
OS12, OS14, OS16	G1/4" (1/4" NPT)
OS22, OS24, OS26	G1/4" (1/4" NPT)
OS32, OS34, OS36	G1/4" (1/4" NPT)
OS42, OS44, OS46	G1/2" (1/2" NPT)

Inlet for heating fluid at the bottom, front connection.
 Outlet for heating fluid at the top, front connection.
 Ensure a link pipe is installed before heating fluid is turned on.

Cautions: Check for leaks, heating fluid could cause burns.

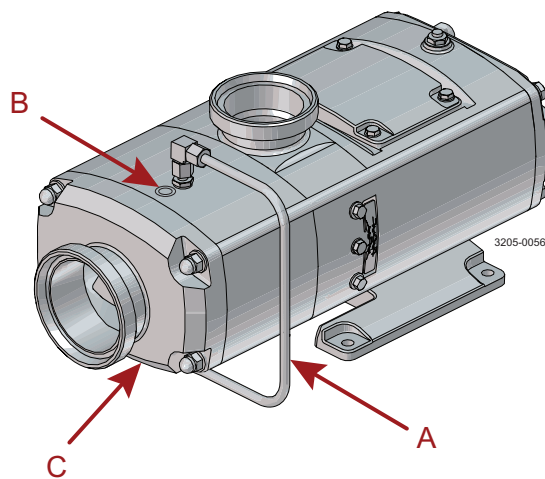

- A) Link Pipe
- B) Outlet
- C) Inlet

5 Maintenance

Take care not to damage shaft surfaces, in particular where bearings and lipseals will be located
 Ensure all fastenings are tightened to the torque settings as shown in Technical Data (See chapter 6 Technical data)

5.10 Rectangular Inlet (option)

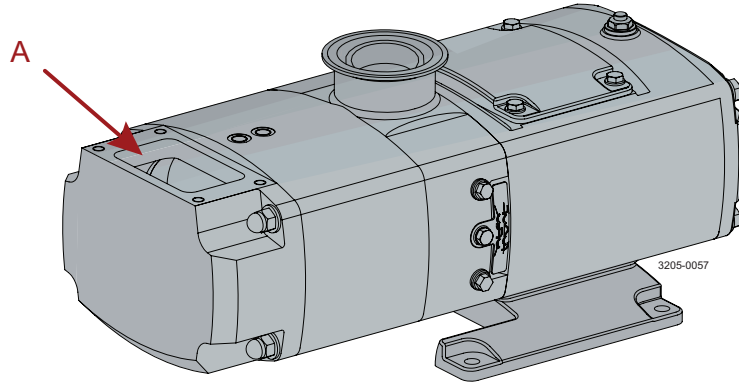

A) Rectangular Inlet

The mating adaptor and gaskets/seals should conform to country specific hygienic regulations such as 3A.

For sizes please see diagram and table below.

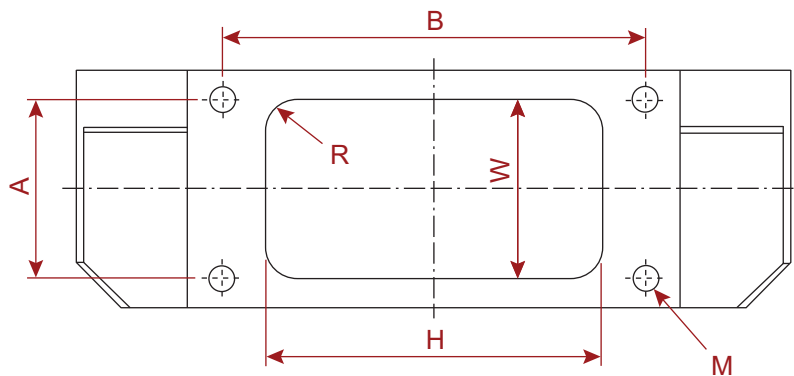

Dimension mm	Model			
	OS12, OS14, OS16	OS22, OS24, OS26	OS32, OS34, OS36	OS42, OS44, OS46
A	48	50	65	80
B	80	110	140	190
H	65	90	110	150
W	48	50	65	80
R	10	10	10	10
M	M8	M8	M10	M12

Take care not to damage shaft surfaces, in particular where bearings and lipseals will be located
 Ensure all fastenings are tightened to the torque settings as shown in Technical Data (See chapter 6 Technical data)

5.11 Trouble shooting

Problem											Probable Causes	Solutions				
No flow	Under capacity	Irregular discharge	Low discharge pressure	Pump will not prime	Prime lost after starting	Pump stalls when starting	Pump overheats	Motor overheats	Excessive power absorbed	Noise and vibration			Pump element wear	Syphoning	Seizure	Mechanical seal leakage
✓				✓											Incorrect direction of rotation.	Reverse motor.
✓															Pump not primed.	Expel gas from suction line and pumping chamber and introduce fluid.
	✓	✓	✓		✓					✓					Insufficient NPSH available.	Increase suction line diameter. Increase suction head. Simplify suction line configuration and reduce length. Reduce pump speed.
		✓	✓	✓	✓					✓					Fluid vaporising in suction line.	Increase suction line diameter. Increase suction head. Simplify suction line configuration and reduce length. Reduce pump speed.
✓	✓	✓	✓	✓	✓	✓				✓			✓		Air entering suction line. Strainer or filter blocked.	Remake pipework joints. Service fittings.
	✓				✓	✓	✓	✓	✓	✓					Fluid viscosity above rated figure.	Increase fluid temperature. Decrease pump speed. Check seal face viscosity limitations.
✓	✓	✓													Fluid viscosity below rated figure.	Decrease fluid temperature. Increase pump speed.
						✓			✓	✓			✓	✓	Fluid temp. above rated figure.	Reduce fluid temperature. Check seal face and elastomer temp. limitations.
						✓	✓	✓							Fluid temp. below rated figure.	Increase fluid temperature.
										✓	✓		✓	✓	Unexpected solids in fluid.	Clean the system. Fit strainer to suction line.
✓	✓	✓			✓	✓	✓	✓	✓	✓	✓		✓	✓	Discharge pressure above rated figure	Check for obstructions i.e. closed valve. Service system and change to prevent problem recurring. Simplify discharge line to decrease pressure.
													✓		Seal flushing inadequate.	Increase flush flow rate. Check that flush fluid flows freely into seal area.
	✓							✓	✓	✓					Pump speed above rated figure.	Decrease pump speed.
✓	✓														Pump speed below rated figure.	Increase pump speed.
	✓						✓	✓	✓	✓	✓		✓		Pump casing strained by pipework.	Check alignment of pipes. Fit flexible pipes or expansion fittings. Support pipework.
							✓		✓	✓	✓		✓		Flexible coupling misaligned.	Check alignment and adjust mountings accordingly.
							✓	✓	✓	✓	✓		✓		Insecure pump driver mountings.	Fit lock washers to slack fasteners and re-tighten.
							✓	✓	✓	✓	✓		✓	✓	Shaft bearing wear or failure.	Refer to pump maker for advice and replacement parts.
							✓	✓	✓	✓	✓		✓		Insufficient gearcase lubrication.	Refer to pump maker's instructions.
✓	✓						✓	✓	✓	✓	✓		✓		Metal to metal contact of pumping element.	Check rated and duty pressures. Refer to pump maker.
✓		✓													Worn pumping element.	Fit new components.
✓				✓											Suction lift too high.	Lower pump or raise liquid level.
														✓	Fluid pumped not compatible with materials used.	Use optional materials.
														✓	No barrier in system to prevent flow passing.	Ensure discharge pipework higher than suction tank.
														✓	Pump allowed to run dry.	Ensure system operation prevents this. Fit single or double flushed mechanical seals.
								✓	✓						Faulty motor.	Check and replace motor bearings.
✓															Pumping element missing	Fit pumping element.

6 Technical data

Take care not to damage shaft surfaces, in particular where bearings and lipseals will be located
Ensure all fastenings are tightened to the torque settings as shown in Technical Data (See chapter 6 Technical data)

6.1 Technical data

6.1.1 Lubrication

Pump Model	Oil capacities litres (US Pints)
OS12 / OS14 / OS16	0.5 (1.06)
OS22 / OS24 / OS26	1.0 (2.11)
OS32 / OS34 / OS36	2.0 (4.22)
OS42 / OS44 / OS46	3.0 (6.34)

6.1.2 Weights

Pump Model	Bare Shaft Pump kg (lb)
OS12 / OS14 / OS16	33 (73)
OS22 / OS24 / OS26	55 (121)
OS32 / OS34 / OS36	105 (231)
OS42 / OS44 / OS46	215 (474)

6.1.3 Speed Limits

Viscosity cP	Max Process Speed / Max CIP Inter Speeds											
	OS1x		OS2x		OS3x		OS4x					
	rpm											
1	2800	/	3300	2500	/	3300	2200	/	3000	1800	/	2800
10	2800	/	3300	2500	/	3300	2200	/	3000	1800	/	2500
100	2800	/	3300	2500	/	3300	2200	/	3000	1800	/	2500
250	2800	/	2930	2500	/	2930	2200	/	2930	1800	/	2500
500	2135	/	2135	2135	/	2135	2135	/	2135	1800	/	2135
1000	1570	/	1570	1570	/	1570	1570	/	1570	1570	/	1570
5000	815	/	815	815	/	815	815	/	815	815	/	815
10000	635	/	635	635	/	635	635	/	635	635	/	635
50000	395	/	395	395	/	395	395	/	395	395	/	395
75000	360	/	360	360	/	360	360	/	360	360	/	360
100000	340	/	340	340	/	340	340	/	340	340	/	340

6.1.4 Pressure Limits

Pump Configuration	Flow direction	OSx2	OSx4 barg (psi)	OSx6
Standard	Standard (Front-In/Top-Out)	16 (232)	12 (174)	8 (116)
Standard	Reversed (Front-Out/Top-In)	6 (87)	5.5 (80)	3.5 (50)
Bearings & Pump Casing	Reversed (Front-Out/Top-In)	13.5 (195)	10 (145)	6.5 (94)

6.1.5 Operating Temperature limits

Pump Model	Max Operating Temperature	
	Continuous (Process)	Intermittent (CIP)
	°C (°F)	
All Models	100 (212)	150 (302)

6 Technical data

Take care not to damage shaft surfaces, in particular where bearings and lipseals will be located
Ensure all fastenings are tightened to the torque settings as shown in Technical Data (See chapter 6 Technical data)

6.1.6 Tool requirements

Description	Tool required	Pump Model			
		12 / 14 / 16	22 / 24 / 26	32 / 33 / 36	42 / 44 / 46
Front cover, gearbox (21)	Socket Size (mm)	17	17	19	24
	Torque (Nm)	36	36	63	143
	Torque (lbft)	26.5	26.5	46.5	105.5
Feed screw nut (24)	Socket Size (mm)	24	24	30	36
	Torque (Nm)	60	60	120	160
	Torque (lbft)	44.3	44.3	88.5	118
Seal housing retention screw (51)	Allan Key Size (mm)	5	5	6	8
	Torque (Nm)	7	7	18	36
	Torque (lbft)	5.2	5.2	13.3	26.6
Seal retention plug (49)	Key Size (mm)	13	13	13	13
	Torque (Nm)	20	20	20	20
	Torque (lbft)	14.8	14.8	14.8	14.8
Gearbox end cover bolt (43)	Socket Size (mm)	13	13	13	13
	Torque (Nm)	18	18	18	18
	Torque (lbft)	13.3	13.3	13.3	13.3
Gear sleeve bolts (9)	Socket Size (mm)	8	8	10	13
	Torque (Nm)	7	7	11	26
	Torque (lbft)	5.2	5.2	8.1	19.2
Bearing retainer bolts (52)	Socket Size (mm)	10	10	13	17
	Torque (Nm)	7	7	18	35
	Torque (lbft)	5.2	5.2	13.3	25.8
Gearbox foot screws (47)	Allan Key Size (mm)	6	8	8	10
	Torque (Nm)	18	18	18	36
	Torque (lbft)	13.3	13.3	13.3	26.6
Gearbox drain plug (50)	Key Size (mm)	19	19	19	19
	Torque (Nm)	15	15	15	15
	Torque (lbft)	11.1	11.1	11.1	11.1
Oil sight glass /45)	Key Size (mm)	23	23	23	23
	Torque (Nm)	35	35	35	35
	Torque (lbft)	25.8	25.8	28.5	25.8

6.1.7 Solids Handling

Maximum Solids Handling mm (inch.)							
OS1x		OS2x		OS3x		OS4x	
OS12	6 (0.24)	OS22	12 (0.47)	OS32	16 (0.63)	OS42	21 (0.82)
OS14	11 (0.43)	OS24	16 (0.63)	OS34	21 (0.82)	OS44	29 (1.14)
OS16	17 (0.67)	OS26	24 (0.94)	OS36	32 (1.26)	OS46	43 (1.69)

6 Technical data

Take care not to damage shaft surfaces, in particular where bearings and lipseals will be located
 Ensure all fastenings are tightened to the torque settings as shown in Technical Data (See chapter 6 Technical data)

6.2 Pumphead Clearance information

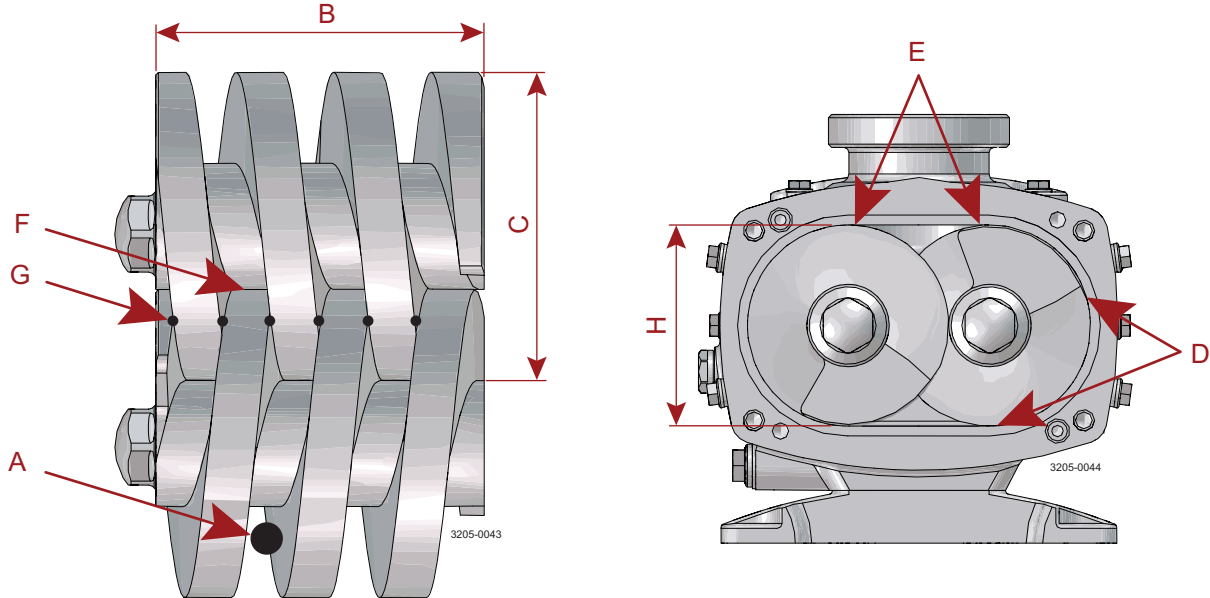

- A) Solids handling max ball diameter
- B) Screw Length
- C) Screw Diameter
- D) Radial

- E) Radial Scallop Clearance
- F) Root Clearance
- G) Mesh Clearance
- H) Screw Case Diameter

Minimum mesh clearance at any mesh position.
 All dimensions in millimeters

	Solids Handling Max. Diameter A	Screw Length B	Screw Diameter C	Radial learance D	Radial Scallop Clearance E	Root Clearance F	Minimum Mesh G
OS 12 16 BAR	6.8	70.0	min 74.000	min 0.105	min 0.185	min 0.1175	0.085
OS 14 12 BAR	8.5	70.0	min 74.000	min 0.105	min 0.185	min 0.1175	0.085
OS 16 8 BAR	17.8	70.0	min 74.000	min 0.105	min 0.185	min 0.1175	0.085
OS 22 16 BAR	13.0	100.0	min 93.690	min 0.173	min 0.293	min 0.187	0.085
OS 24 12 BAR	17.5	100.0	min 93.690	min 0.173	min 0.293	min 0.187	0.085
OS 26 8 BAR	26.0	100.0	min 93.690	min 0.173	min 0.293	min 0.187	0.100
OS 32 16 BAR	15.5	130.0	min 121.620	min 0.210	min 0.330	min 0.228	0.090
OS 34 12 BAR	23.0	130.0	min 121.620	min 0.210	min 0.330	min 0.228	0.090
OS 36 8 BAR	33.5	130.0	min 121.620	min 0.210	min 0.330	min 0.228	0.130
OS 42 16 BAR	22.5	175.0	min 162.530	min 0.255	min 0.375	min 0.273	0.105
OS 44 12 BAR	31.0	175.0	min 162.530	min 0.255	min 0.375	min 0.273	0.115
OS 46 8 BAR	45.5	175.0	min 162.530	min 0.255	min 0.375	min 0.273	0.190

7.1 Twin Screw Pump Range (All Models)

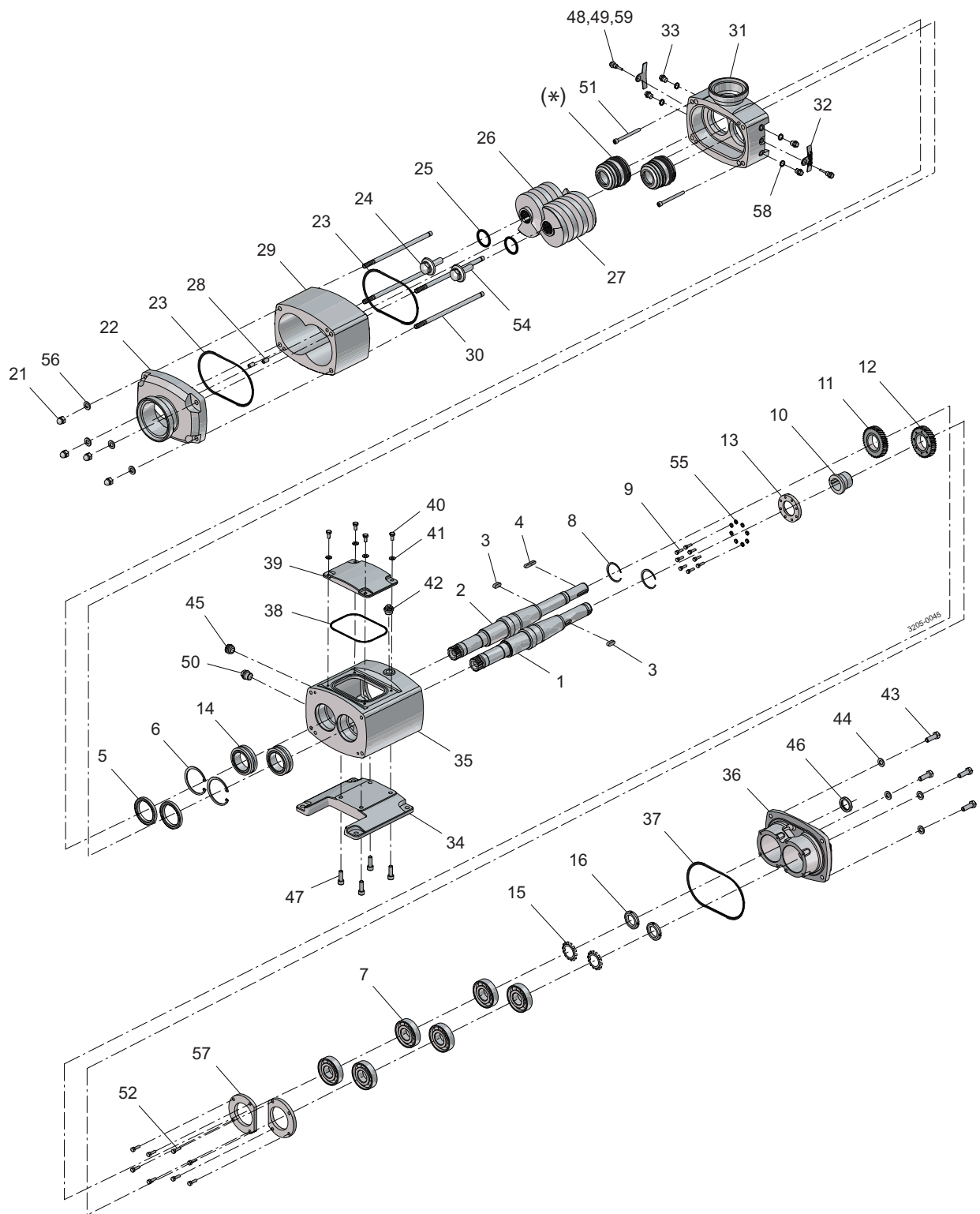

* Cartridge Seal

7 Parts list

Parts list

Pos.	Qty	Denomination
1	1	Auxiliary Shaft
2	1	Drive Shaft
3	1	Gear Key
4	1	Drive Shaft Key
5 ●	2	Front Lip Seal
6	2	Circlip
7	6	Ball Bearing
8	2	Circlip
9	8	Gear Sleeve Bolts
10	1	Gear Sleeve
11	1	Timing Gear Drive Shaft
12	1	Timing Gear Auxilliary Shaft
13	1	Timing Gear Clamp Plate
14	2	Needle Bearing
15	2	Tab Washer
16	2	Bearing Nut
21	4	Front Cover Nut
22	1	Pump Cover
23 ★	2	Pump Casing Elastomer
24	2	Feed Screw Nut
25 ★	2	Feed Screw Elastomer
26	1	Feed Screw
27	1	Feed Screw
28	6	Pump Casing Dowels
29	1	Pump Casing
30	4	Pump Casing Studs
31	1	Seal Housing
32	2	Gland Guard
33	4	Flush Plugs
34	1	Foot
35	1	Gearbox
36	1	Gearbox End Cover
37 ●	1	Gearbox End Cover O-Ring
38 ●	1	Gearbox Top Cover O-Ring
39	1	Gearbox Top Cover
40	4	Gearbox Top Cover Bolts
41	4	Gearbox Top Cover Washers
42	1	Filler Plug
43	4	Gearbox End Cover Bolts
44	4	Gearbox End Cover Washers
45	1	Sight Glass
46 ●	1	Rear Lip Seal
47	4	Gearbox Foot Screw
48	2	Gland Guard Plug
49	2	Seal Pin
50	1	Washer Gearbox Plug
51	2	Cap Screw
52	8	Hex Bolt
54	2	Stud bolt
55	1	Washer
56	4	Washer
57	2	Bearing Retainer
58	4	Washer Seal Ring
59 ★	2	Gland Guard Screw O Ring
60	2	Heating Pipe Union - Not shown
61	2	Heating Pipe Elbow - Not shown
62	1	Heating Pipe - Not shown

How to contact Alfa Laval

Contact details for all countries are continually updated on our website.

Please visit www.alfalaval.com to access the information directly.

© Alfa Laval Corporate AB

This document and its contents is owned by Alfa Laval Corporate AB and protected by laws governing intellectual property and thereto related rights. It is the responsibility of the user of this document to comply with all applicable intellectual property laws. Without limiting any rights related to this document, no part of this document may be copied, reproduced or transmitted in any form or by any means (electronic, mechanical, photocopying, recording, or otherwise), or for any purpose, without the expressed permission of Alfa Laval Corporate AB. Alfa Laval Corporate AB will enforce its rights related to this document to the fullest extent of the law, including the seeking of criminal prosecution.