

INSTALLATION, SERVICE AND MAINTENANCE INSTRUCTIONS

BUTTERFLY VALVE

A480 / A490

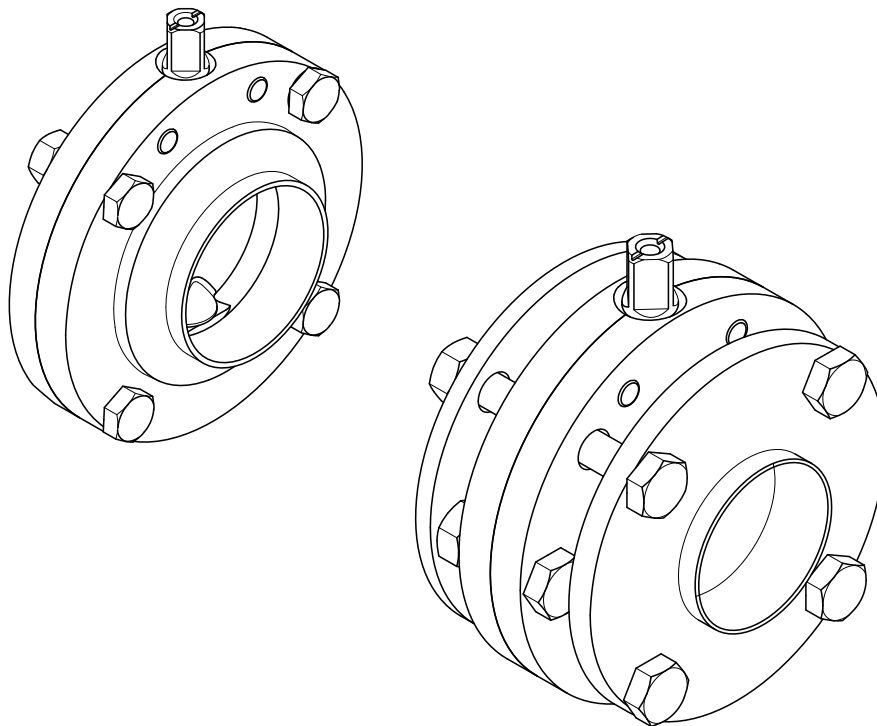

10.010.32.0024



www.sks-online.com

Original Instructions

10.010.30.01EN

(A) 2020/12



INOXPA S.A.U.
Telers, 60
17820 - Banyoles (Spain)

hereby declare under our sole responsibility that the

Machine: **VALVE**

Model: **BUTTERFLY**

Type: **A480 / A490 (DN 25 - DN 100 / OD 1" - OD 4")**

Size: **DN 25 - DN 100 / OD 1" - OD 4" / SMS 25 - SMS 104**

Serial number: **IXXXXXX o XXXXXXXXXIIN**

fulfills all the relevant provisions of the following directive:

Machinery Directive 2006/42/EC¹
Pressure Equipment Directive 2014/68/EU
Regulation (EC) n° 1935/2004
ATEX Directive 2014/34/EU²

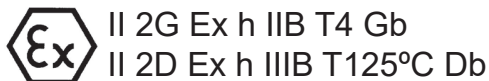

and with the following harmonized standards and/or regulations:

EN ISO 12100:2010, EN 1127-1:2019, EN ISO 13732-1:2008, EN 1672-2:2005+A1:2009, EN 1127-1:2019², EN 13237:2012², EN 15198:2007², EN ISO 80079-36:2016², EN ISO 80079-37:2016², EN IEC 60079-0:2018², EN 19:2016, EN 12266-1:2012

The technical file has been prepared by the signer of this document.

A copy of the technical file is in the possession of the notified body L.C.I.E. with reference number 0081

David Reyero Brunet
Technical Office Manager
9th December 2020



Document: 10.010.30.03EN
Revision: (A) 2020/12

1) A480/A490 with pneumatic actuator A940 series
2) A480/A490 that bears the specific marking of explosion protection and with the following drives: four positions handle, two positions handle, metal multiposition handle, lock handle, micrometric handle and actuator A940 series.
www.sks-online.com

1. Table of Contents

1. Table of Contents	
2. Generalities	
2.1. Instructions manual.....	5
2.2. Compliance with the instructions	5
2.3. Warranty.....	5
3. Safety	
3.1. Warning symbols.....	6
3.2. General safety instructions	6
4. General Information	
4.1. Description	8
4.2. Application.....	8
4.3. Scope of the ATEX Certification.....	8
5. Installation	
5.1. Reception of the valve	9
5.2. Transport and storage.....	9
5.3. Identification of the valve	9
5.4. Location	11
5.5. General installation	11
5.6. Checking and review.....	11
5.7. Welding.....	12
5.8. Connecting the air to actuator.....	14
6. Start-up	
6.1. Operating with two-position handle.....	16
6.2. Operating with multiposition handle.....	16
7. Operating problems	17
8. Maintenance	
8.1. General considerations	18
8.2. Maintenance	18
8.3. Cleaning.....	19
8.4. Disassembly and assembly the valve	21
8.5. Disassembly and assembly of the butterfly valve A480	22
8.6. Disassembly and assembly of the butterfly valve between flanges A490.....	23
8.7. Disassembly and assembly of the manual drive.....	24
8.8. Disassembly and assembly of the pneumatic drive	25
8.9. Fitting the seat seal.....	26
8.10. Actuator fitting options.....	26
8.11. Valve position	26
9. Technical Specifications	
9.1. Valve	27
9.2. Actuator.....	27
9.3. Materials	28
9.4. Sizes available	28
9.5. Tightening torque	28
9.6. Weight of the butterfly valve A480	29
9.7. Weight of the butterfly valve between flanges VALVE A490	29
9.8. Dimensions of the butterfly valve A480 with two-positions handle.....	30
9.9. Dimensions of the butterfly valve between flanges A490 with two-positions handle	30
9.10. Dimensions of the butterfly valve A480 with multiposition handle.....	31
9.11. Dimensions of the butterfly valve between flanges A490 with multiposition handle.....	31
9.12. Dimensions of the butterfly valve A480 with actuator	32

9.13. Dimensions of the butterfly valve between flanges A490 with actuator 32
9.14. Dimensions of the butterfly valve A480 with actuator and C-TOP S 33
9.15. Dimensions of the butterfly valve between flanges A490 with actuator and C-TOP S 33
9.16. Exploded drawing and parts list of the butterfly valve A480..... 34
9.17. Exploded drawing and parts list of the butterfly valve between flanges A490 35
9.18. Exploded drawing and parts list of the butterfly valve's drives A480 / A490 36

2. Generalities

2.1. INSTRUCTIONS MANUAL

This manual contains information about the reception, installation, operation, assembly and maintenance of the butterfly valve A480 and the butterfly valve between flanges A490.

Carefully read the instruction prior to starting the valve, familiarize yourself with the installation, operation and correct use of the valve and strictly follow the instructions. These instructions should be kept in a safe location near the installation area.

The information published in the instruction manual is based on updated data.

INOXPA reserves the right to modify this instruction manual without prior notice.

2.2. COMPLIANCE WITH THE INSTRUCTIONS

Not following the instructions may impose a risk for the operators, the environment and the machine, and may cause the loss of the right to claim damages.

This non-compliance may cause the following risks:

- failure of important machine/plant functions,
- failure of specific maintenance and repair procedures,
- possible electrical, mechanical and chemical hazards,
- risk to the environment due to the type of substances released.

2.3. WARRANTY

The conditions of the warranty are specified in the General Sales Condition that has been delivered at the time of placing your order.



The machine may not undergo any modification without prior approval from the manufacturer.

For your safety, only use original spare parts and accessories. The usage of other parts will relieve the manufacturer of any liability.

Changing the service conditions can only be carried out with prior written authorization from INOXPA.

Please do not hesitate to contact us in case of doubts or if further explanations are required regarding specific data (adjustments, assembly, disassembly, etc.).

3. Safety

3.1. WARNING SYMBOLS



Safety hazard for people in general and/or equipment



Important indications for explosion protection

ATTENTION

Important instruction to prevent damage to the equipment and/or its function

3.2. GENERAL SAFETY INSTRUCTIONS



Read the instruction manual carefully before installing and starting the valve. Contact INOXPA in case of doubt.

3.2.1. During installation



Always take into account the [Technical Specifications of chapter 9](#).

The installation and use of the valve should always be in accordance with applicable regulations regarding health and safety.

Before starting up the valve, check that it is assembled correctly and its shaft is perfectly aligned. Incorrect alignment and/or excessive stress during coupling can cause serious mechanical problems in the valve.



Do an earth connection of the valve in order to ensure electrical continuity between pipes and valves to reduce a risk caused by the static electricity.

3.2.2. During operation



Always take into account the [Technical Specifications of chapter 9](#).

NEVER exceed the specified limit values.

NEVER touch the valve and/or piping that is in contact with the fluid during operation. If the process involves hot products there is a risk of burns.

The valve contains parts that move in a linear fashion. Do not place hands or fingers in the valve closing area. This can cause serious injury.



NEVER exceed limit values of the working conditions in explosive atmospheres.

The valve and/or the actuator have been selected according to the working conditions specified by the customer. INOXPA is not responsible for damages caused by using the valve in different working conditions than those expressed by the customer.

3.2.3. During maintenance



Always take into account the [Technical Specifications of chapter 9](#).

NEVER disassemble or remove the valve until the pipes have been emptied. Bear in mind that the fluid in the pipe may be hazardous or extremely hot. Consult the regulations in effect in each country for these cases.

Inside the actuator there is a spring with an applied load. The steps specified in this manual must be followed when performing maintenance operations to avoid injury.

Do not leave loose parts on the floor.



All assembly/disassembly works of the valve and/or actuator that be carried out in explosive atmospheres or in places where can be generated must be carried out by authorised personnel to work in explosive atmospheres.

4. General Information

4.1. DESCRIPTION

The butterfly valve A480 is a valve which is operated manually or automatically in order to interrupt or regulate the flow of a fluid.

The butterfly valve between flanges A490 allows an easy assembly and disassembly of the valve without having to separate the pipes.

For the manual operation, you can use a two-position handle, which locks the butterfly in open or close position, or other types of the handle in order to get intermediate positions.

For the automatic operation, the actuator transforms the axial movement in a 90° movement which is transmitted to the butterfly.

4.2. APPLICATION

Butterfly valves, whether manually or automatically operated, can be used in most liquid product applications in the food-processing, pharmaceutical and chemical industries.

4.3. SCOPE OF THE ATEX CERTIFICATION

Only valves compliant with the essential health and safety requirements of ATEX Directive 2014/34/EU, the valves that bear the specific marking of explosion protection and the valves fitted with a four-position handle, two-position handle, metal multiposition handle, lock handle, micrometric handle and actuator A940 series, all of them INOXPA brand.

The manufacturer of an assembly consisting of different compliant pieces of equipment or components as defined by ATEX Directive 2014/34/EU, must perform his own risk assessment of the assembly and fulfil with all the obligations of manufacturers that are required in the ATEX Directive 2014/34/EU.

5. Installation

5.1. RECEPTION OF THE VALVE



INOXPA is not liable for any deterioration of the material caused by its transport or unpacking.



Check that the valve and/or actuator adjust at the requests working conditions and the classified explosive atmosphere.

When receipt the valve, check to see whether all the parts listed on the delivery slip are present:

- complete valve
- its components if any are supplied,
- instruction manual.

INOXPA inspects all its equipment before packaging. However, it cannot guarantee that the merchandise arrives at the user intact.

When unpacking the valve:

- remove any possible traces of packaging from the valve or its parts,
- inspect the valve or the parts that comprise it for possible damage incurred during shipping,
- take all possible precautions against damage to the valve and its components.

5.2. TRANSPORT AND STORAGE



The buyer or user shall be liable for assembly, installation, start-up and operation of the valve.

Take all possible precautions when transport and storage the valve to avoid damage it and its components.

5.3. IDENTIFICATION OF THE VALVE

Each valve and each actuator is inscribed a fabrication number for its identification and also, the valves that fulfil the ATEX Directive bear the specific marking of explosion protection. Indicate the fabrication number on all documents to refer to the valve.

The specific marked for the explosion protection for the valve and/or actuator is:

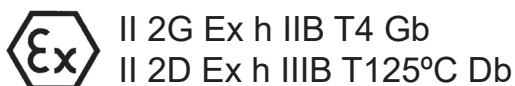

VA	48	0	-	00	06	52	050
							Size
							025 DN 25, OD 1"
							040 DN 40
							045 OD 1½"
							050 DN 50, OD 2"
							063 OD 2½"
							065 DN 65
							076 OD 3"
							080 DN 80
							100 DN 100, OD 4"
							Material of seat seals
							43 HNBR
							52 EPDM
							78 FPM
							61 VQM
							Material
							04 1.4307 (AISI 304L)
							06 1.4404 (AISI 316L)
							Connexions
							00 weld/weld
							10 male/weld
							11 male/male
							77 clamp/clamp
							Standard pipe
							0 DIN
							1 OD
							Type
							48 butterfly valve A480
							49 butterfly valve between flanges A490
							Product family
VA	valve						

5.4. LOCATION

Place the valve leaving enough space around it to realize easily the dismantling, the inspection and the review the valve as well as in order to access to the actuator air connection's device for valves with automatic actuation even when the valve is operating. Consult in chapter 5.7. **Welding** the required minimum distances. The installation should allow that the removable parts are could remove easily.

5.5. GENERAL INSTALLATION

After the location of the valve is defined, the valve can be joined to the pipe by welding the valve housing or using fittings.



Ground the assembly to ensure electrical continuity between pipes and valve to reduce the danger from static electricity.

In case of joining the valve to the pipe by fittings do not forget the seals and tighten the unions properly.

During installation, the valve avoids using excessive force and pay special attention to:

- vibrations that may be produced on the facility,
- thermal dilation that the pipe may undergo when hot fluids are circulating,
- the weight that the pipe can support,
- excessive welding current.

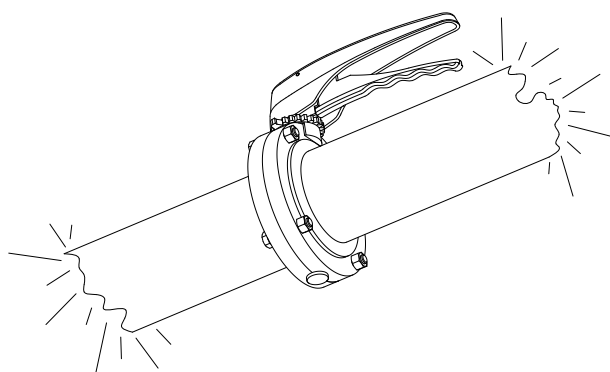

10.010.32.0002

5.6. CHECKING AND REVIEW

Perform the following checks before using the valve:

- open and close the valve several times in order to ensure that it works properly and check that the butterfly smoothly connects up to the coupling.
- if the valve is fitted with a pneumatic drive, apply the compressed air several times checking to make sure that the valve carries out the opening and closing action without difficulty.

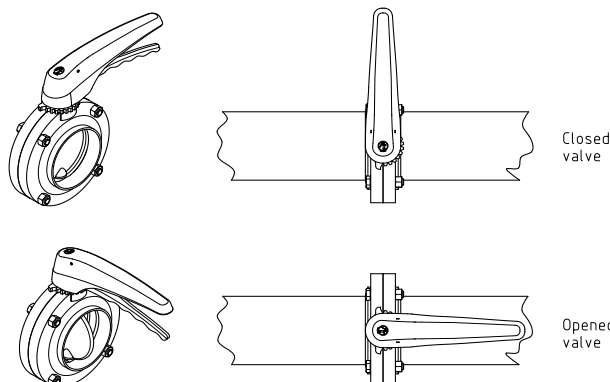

10.010.32.0054

5.7. WELDING



Welding work should only be done by qualified persons who are trained and equipped with the necessary equipment to perform this kind of work.



If possible, do the welding work in areas not classified as potentially explosive atmospheres. If it is not possible, the welding work in areas classified as potentially explosive atmospheres must be carried out by authorised personnel to work in explosive atmospheres.

For the welding works on the SMS size values, consult the size equivalences in chapter 8.2.3. [Spare parts](#).

5.7.1. Butterfly valve A480 welding/welding

To perform the welding works:

- disassemble the valve as indicated in chapter 8.5. [Disassembly and assembly of the butterfly valve A480](#),
- weld the two valve laterals to the pipes maintaining the distance indicated in the following table, dimension A. This will allow an axial movement of the internal part of the valve necessary to disassemble the internal pieces (disc and seat seal).
- Mount the valve following the instructions indicated in chapter 8.5. [Disassembly and assembly of the butterfly valve A480](#).

DN	A (mm)
25 - 1"	23
32	23
40 - 1½"	25
50 - 2"	25
65 - 2½"	25
80 - 3"	27
100 - 4"	27

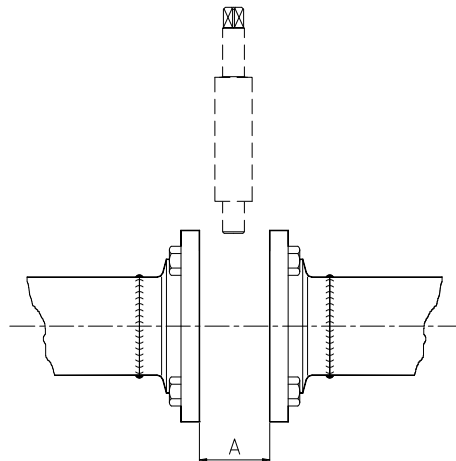

10.010.32.0004

5.7.2. Butterfly valve between flanges A490 welding/welding

To perform the welding works:

- Loosen the screws and the nuts which join the flanges to the lateral flanges and separate the flanges. For more information see chapter 8.6. [Maintenance of the seals](#),
- weld the two flanges to the pipes maintaining the distance indicated in the following table, dimension B. This will allow an axial movement of the central part of the valve necessary to disassemble the internal pieces.

DN	B (mm)
25 - 1"	48
32	48
40 - 1½"	48
50 - 2"	48
65 - 2½"	48
80 - 3"	48
100 - 4"	48

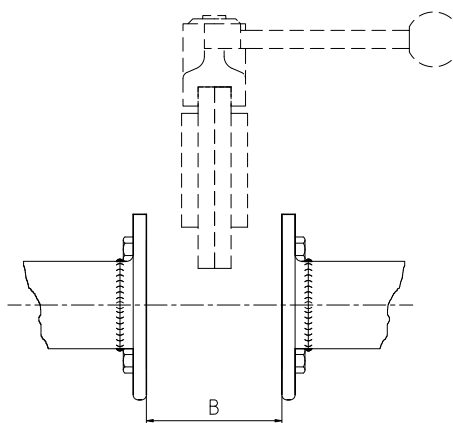

10.010.32.0029

- Mount the valve following the instructions indicated in chapter 8.6. Maintenance of the seals.

5.7.3. Valve with pneumatic drive



If the actuator is not supplied by INOXPA, it must comply with the specifications of ATEX Directive 2014/34/EU and you will have to fulfil the supplier's specifications.

To perform the welding works on valves with the pneumatic drive should be maintained, in addition to the dimensions mentioned in chapters above, a distance which allows disassembly the pneumatic drive and the control head. The minimum distances that must be kept are indicated in the following table, dimension C for valves with a pneumatic drive or dimension D for valves with a pneumatic drive and control head.

DN	C (mm)	D (mm)
25	279	319
32	282	322
40	285	325
50	292	332
65	322	362
80	330	370
100	340	380

DN	C (mm)	D (mm)
1"	276	316
1½"	283	323
2"	289	329
2½"	317	357
3"	324	364
4"	340	380

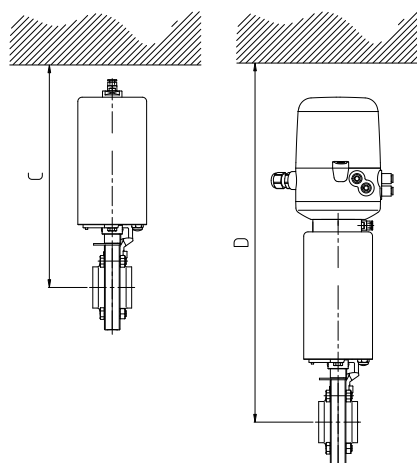

10.010.32.0005

5.8. CONNECTING THE AIR TO ACTUATOR

To perform the air connection to the actuator:

- Connect and check the air connections (G 1/8" thread for tubing Ø6 mm) with thread in accordance with double-effect or simple effect needs.
- Correctly orient the actuator and disc depending whether an NO/NC is required. By turning the butterfly 90° achieves one or the other solution.
- Mind the quality of the compressed air according to the specifications described in chapter 9. [Technical Specifications](#).

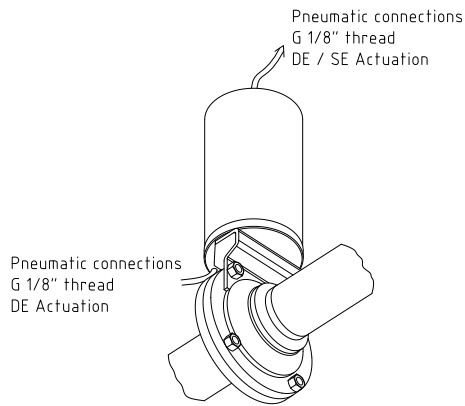

6. Start-up



Read carefully the instructions in chapter 5. [Installation](#) before start-up the valve.



Before to start-up, the persons in charge must be duly informed about how the valve works and the safety instructions to follow. This instruction manual will be available to personnel at all times.



Check that the valve and/or actuator are in accordance with the working conditions specified by the customer and with the potentially explosive atmosphere classified. Do an earth connection of the valve in order to ensure electrical continuity between pipes and valves to reduce a risk caused by the static electricity. NEVER remove the handle of the valve because it would remain electrically isolated.

Before putting the valve or the actuator into service the following must be taken into consideration:

- check that the piping and valve are completely free of possible traces of welding slag or other foreign particles. Clean the system if is necessary,
- Check to make sure the valve moves smoothly. If necessary, lubricate it with special grease or soapy water,
- Check for possible leaks, and make sure the pipes and their connections are sealed and do not have any leaks,
- If the valve has been supplied with an actuator, make sure that the alignment of the valve shaft and the actuator shaft enables smooth movement,
- check that the compressed air pressure at the inlet of the actuator matches what is indicated in chapter 9. [Technical Specifications](#),
- consider the quality of the compressed air, according to the specifications described in chapter 9. [Technical Specifications](#),
- Activate the valve.

ATTENTION



Do not modify the operating parameters for which the valve has been designed without prior written authorisation from INOXPA.

Do not touch the moving parts of the coupling between the actuator and the valve when the actuator is connected to the compressed air supply.



¡Burn hazard! Do not touch the valve or the pipes when hot fluids are circulating or when cleaning and/or sterilization are being carried out.



Do not modify the operating parameters for which the valve has been designed without prior written authorisation from INOXPA.

The valve and/or the actuator have been selected according to the working conditions specified by the customer. INOXPA is not responsible for damages caused if the information provided by the customer as nature of the liquid, viscosity, the classification of the potentially explosive atmosphere, etc. is incomplete or incorrect.

6.1. OPERATING WITH TWO-POSITION HANDLE

The two-position handle allows operating the valve manually in the on/off position. To manoeuvre the handle follow the following instructions.

- pull the handle outwards,
- while pulling the handle turn it 90°.

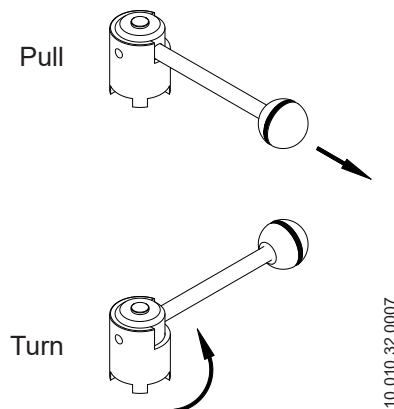

6.2. OPERATING WITH MULTIPOSITION HANDLE

The multiposition handle allows the gradual opening and closing of the valve with five positions. To manoeuvre the handle follow the following instructions:

- pull the catch finger upwards,
- while the catch finger is held in position turn the handle. Release the catch finger to place it the desired close position.

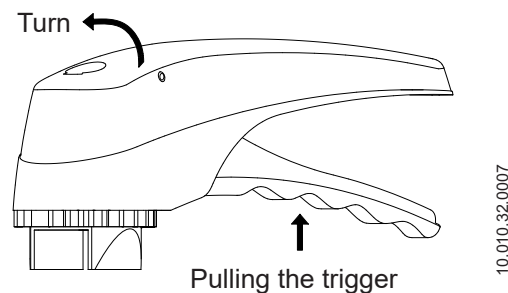

7. Operating problems

External leak. The product is leaking at the shaft		
Internal product leak (closed valve)		
The valve is jerking		
The valve does not open/close		
Water hammer		
PROBABLE CAUSES		SOLUTIONS
The seal has completely worn or is deteriorated		- Replace the seal - Change the seals for others made of a different material more suitable to the product
Normal wear and tear of the seat seals		- Replace the seals
Premature wearing of seals	Seal worn or affected by the product	- Change the seals for others made of a different material more suitable to the product - Tighten loose parts - Clean frequently - Decrease valve opening/closing frequency
	Excessive pressure on the line	
	Work temperature too high (nuts and screws)	
	Loss of impenetrability (vibrations)	
	High manoeuvre periodicity (num. operations/tour)	
The seals are jamming up		- Lubricate with soapy water or lubricant suitable with the gasket material and the product
The actuator does not operate the valve efficiently		- Check the supply pressure of the compressed air - Replace with a larger sized actuator
Excessive pressure on the line		- Check the installation pressure and adjust whenever necessary
Deformation of the seal		- Replace the seals with others of different quality, if prematurely deteriorated
Incorrect operation of the actuator		- Replace from NC to NO
Worn actuator components		- Check the actuator
Dirt in actuator		- Check the compressed air pressure
The valve closes too fast		- Adjust the closing speed of the actuator with a flow regulator

8. Maintenance

8.1. GENERAL CONSIDERATIONS

This valve, just like any other machine, requires maintenance. The instructions in this chapter cover the maintenance of the valve, the identification and replacement of the spare parts and the disassembly and assembly of the valve. The instructions are aimed at maintenance personnel and those responsible for the supply of spare parts.



Read carefully the chapter [9. Technical Specifications](#).

Maintenance work should only be done by qualified persons who are trained and equipped with the necessary equipment to perform this kind of work.

All replaced material should be duly disposed or recycled according to the directives in effect in each area.

Make sure that the pipes are not under pressure before starting maintenance work.



The assembly and disassembly of the valve and/or actuator must be carried out by authorised personnel to work in explosive atmospheres.

When the valve is supplied without manual drive, actuator or head control and the customer want to install one of them, they will have to fulfil with the regulations of the ATEX Directive 2014/34/UE.

8.2. MAINTENANCE

To perform maintenance properly is recommended:

- periodic inspection of the valve and its components,
- keeping an operational record of each valve writing down any problems,
- always having spare replacement seals in stock.

Pay special attention to the hazard warnings indicated in this manual during the performance of the maintenance work.



Do not touch the moving parts when the actuator is connected to the compressed air.

The valve and the pipes must never be under pressure during maintenance.

¡Burn hazard! Do not touch the valve or the pipes when hot fluids are circulating or when cleaning and/or sterilization are being carried out.

Keep in mind that the springs are not protected during the disassembly of the actuator for its maintenance or its repair.

8.2.1. Maintenance of the seals

REPLACING SEAL	
Preventive maintenance	Replace after 12 months
Maintenance after a leak	Replace at the end of the process
Planned maintenance	Regularly check the absence of leaks and the smooth operation of the valve. Keep a record of the valve's maintenance. Use statistics for planning inspections.
Lubrication	During assembly, apply lubricants that are suitable with the material of which the seat seal is made

COMPONENTE JUNTA	LUBRICANTE	CLASE NLGI DIN 51818
HNBR / FPM / VMQ	klübersynth UH 1 64-2403	3
EPDM / HNBR / FPM	PARALIQ GTE 703	3

The time interval between each preventive maintenance may vary in accordance with the work conditions to which the valve is subject: temperature, pressure, number of operations per day, type of cleaning solutions used, etc.

8.2.2. Storage

The valves should be stored in a closed area under the following conditions:

- temperature between 15°C y 30°C,
- air humidity < 60%

Storage of the equipment in the open air is NOT allowed.

8.2.3. Spare parts



When ordering spare parts for valves and/or actuators which operating in potentially explosive atmospheres you should indicate that to be for valves and/or actuators which operate in ATEX areas and the features of this area. If there is no indication this information INOXPA is not responsible that the valves and/or actuator operated with parts no suitable for the classified area where is installation.

To request spare parts is necessary to indicate the type of valve, the fabrication number, the position and the description of the part which can be found in chapter 9. [Technical Specifications](#).

The space parts of the valve are being centralized on the DIN EN 10357 Serie A and ASTM A269/270 sizes. In the following table, there are equivalences between the different types of size.

DIN EN 10357 Series A	ASTM A269/270	SMS
DN 25	-	-
DN 40	-	-
DN 50	-	-
DN 65	-	-
DN 80	-	-
DN 100	-	104
-	OD 1"	25
-	OD 1½"	38
-	OD 2"	51
-	OD 2½"	63,5
-	OD 3"	76
-	OD 4"	101,6

8.3. CLEANING



The use of aggressive cleaning products such as caustic soda and nitric acid may burn the skin.

Wear rubber gloves during all cleaning procedures.

Always wear protective goggles.



Before start the assembly and disassembly works of the valve and/or actuator take account of the presence or possible formation of potentially explosive atmospheres. Clean the external part of the valve and/or actuator in order to avoid an excessive accumulation of dust, combustible or explosive on the external surface of the machine. Don't be allow accumulations of a thickness greater than 2 mm.

8.3.1. CIP (clean-in-place) cleaning

If the valve is installed in a system with a CIP process its disassembly will not be required. EPDM is the standard seal material that will be used for CIP cleaning, both in alkaline mediums and in acid mediums. The materials of the seal HNBR and FPM are not recommended.

Two types of solutions can be used for CIP processes:

- a. alkaline solution:** 1% by weight of caustic soda (NaOH) a 70°C (150°F). To make this solution:
 1 kg NaOH + 100 l H₂O¹ = cleaning solution
 2,2 l NaOH al 33% + 100 l H₂O = cleaning solution
- b. acid solution:** 0,5% by weight of nitric acid (HNO₃) a 70°C (150°F). To make this solution:
 0,7 l HNO₃ al 53% + 100 l H₂O = cleaning solution

1) only use chlorine-free water to mix with the cleaning agents

ATTENTION



Check the concentration of the cleaning solutions. An incorrect concentrations may lead to the deterioration of the valve seals.

To remove any traces of cleaning products, ALWAYS perform a final rinse with clean water at the end of the cleaning process.



Clean the entire interior and exterior of the valve before starting disassembly and assembly tasks.

8.3.2. Automatic SIP (sterilization-in-place)

Sterilization with steam is applied to all equipment including the pigging.

ATTENTION



Do NOT start the equipment during the sterilization with steam. The parts and the materials will not be damaged if the indications specified in this manual are observed. No cold fluid can enter the equipment until the temperature of the equipment is lower than 60°C (140°F).

Maximum conditions during the SIP process with steam or superheated water:

- a. maximum temperature: 140°C / 284°F
- b. maximum time: 30 min
- c. cooling: sterile air or inter gas
- d. materials: EPDM (the materials HNBR and FPM are not recommended)

8.4. DISASSEMBLY AND ASSEMBLY THE VALVE



Proceed with caution. Personal injury can occur.

Always disconnect the compressed air before starting to disassemble the valve.

Never disassemble the valve clamps directly without reading the instructions carefully, since the actuator contains a spring inside it with an applied load.

Valve and actuator assembly and disassembly should only be done by qualified persons.



The assembly and disassembly of the valve and/or actuator must be carried out by authorised personnel to work in explosive atmospheres.

The following tools are needed in order to disassembly and assembly the valve and the drives:

- two crescent spanners 13 mm for the valve
- a 4 mm allen key for the manual drive
- a crescent spanners 10 mm and a 4 mm allen key for the pneumatic drive

8.5. DISASSEMBLY AND ASSEMBLY OF THE BUTTERFLY VALVE A480



Avoid disassembly the valve in an area defined as a potentially explosive atmosphere because the valve is electrically isolated when it has not a drive.

8.5.1. Disassembly

1. Remove the bottom protective plug (07) from the bottom part of the disc shaft.
2. Loosen the screws (23) and the nuts (26) that join both laterals (02).
3. Separate the laterals (02) and take out the guide bushings (17,17A).
4. Remove the disc (03) with the seat seal (05).
5. Remove the seal (05) from the disc (03) as indicated in chapter 8.9. [Fitting the seat seal](#).

8.5.2. Assembly

1. Fit the disc (03) on the seat seal (05) as indicated in chapter 8.9. [Fitting the seat seal](#). To facilitate the assembly of the valve leaves the disc in the open position.
2. Place the guide bushings (17,17A) into the disc shaft.
3. Fit the disc (03) and the seat seal (05) assembly between the two laterals (02).
4. Position the screws (23) and the nuts (26), screw them crosswise according to the tightening torque value indicated in chapter 9.5. [Tightening torque](#) and check that the seat seal (05) and the guide bushings (17,17A) are positioned correctly.

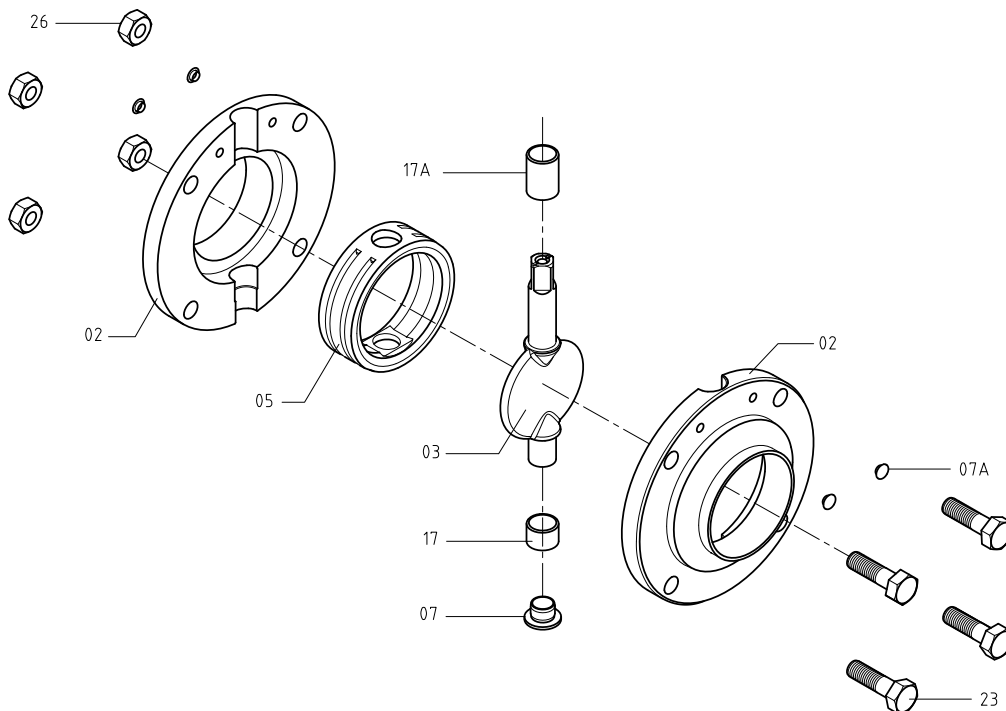

10.010.32.0021

8.6. DISASSEMBLY AND ASSEMBLY OF THE BUTTERFLY VALVE BETWEEN FLANGES A490



Avoid disassembly the valve in an area defined as a potentially explosive atmosphere because the valve is electrically isolated when it has not a drive.

8.6.1. Disassembly

1. Loosen the screws (23A) and the nuts (26A) which join the flanges (02B) to the lateral flanges (02A).
2. Separate the flanges (02B).
3. Remove the flange seals (20) from the lateral flanges (02A).
4. Remove the bottom protective plug (07) from the bottom part of the disc shaft.
5. Loosen the screws (23) and nuts (26) which join the two lateral flanges (02A).
6. Separate the two lateral flanges (02A) and take out the guide bushings (17,17A).
7. Remove the disc (03) with the seat seal (05).
8. Remove the seat seal (05) from the disc (03) as indicated in chapter 8.9. [Fitting the seat seal.](#)

8.6.2. Assembly

1. Fit the disc (03) on the seat seal (05) as indicated in chapter 8.9. [Fitting the seat seal.](#) To facilitate the assembly of the valve leaves the disc in the open position.
2. Place the guide bushings (17,17A) into the disc shaft.
3. Place the bottom protective plug (07) to the bottom part of the disc's shaft
4. Fit the disc (03) and the seat seal (05) assembly between the lateral flanges (02A).
5. Position the screws (23) and the nuts (26), screw them crosswise according to the tightening torque value indicated in chapter 9.5. [Tightening torque.](#) Check that the seat seal (05) and the guide bushings (17,17A) are positioned correctly.
6. Place the flange seals (20) in the lateral flanges (02A).
7. Place the screws (23A) and the nuts (26A) which join the flanges (02B) to the lateral flanges (02A) and screw them according to the tightening torque value indicated in chapter 9.5. [Tightening torque.](#)

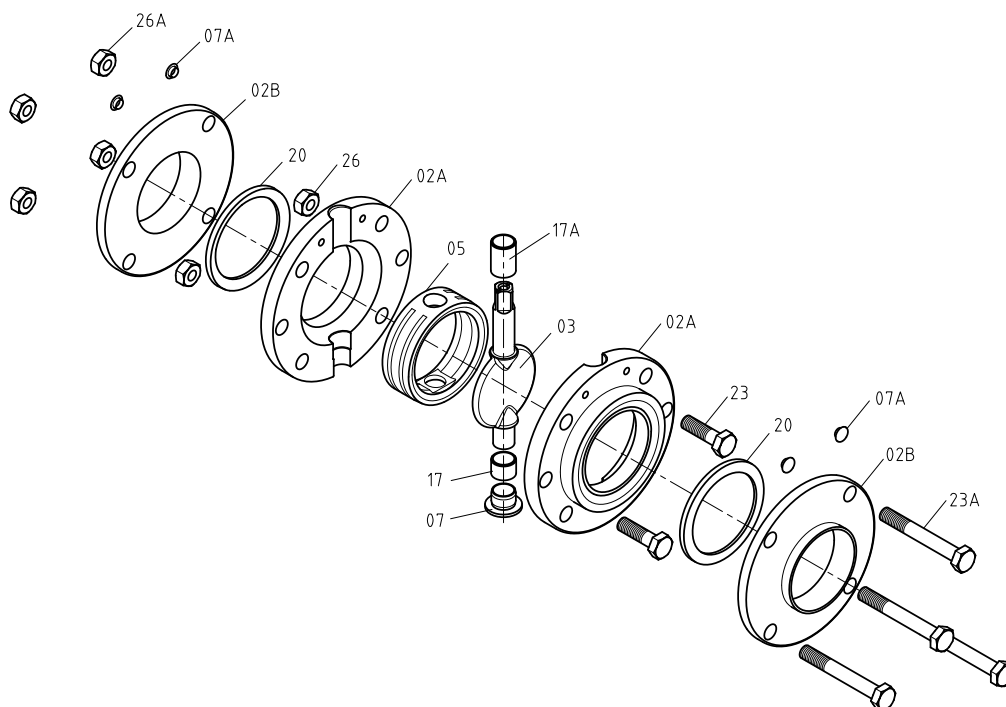

8.7. DISASSEMBLY AND ASSEMBLY OF THE MANUAL DRIVE



When the valve is supplied without manual drive, actuator or head control and the customer want to install one of them, they will have to fulfil with the regulations of the ATEX Directive 2014/34/UE.

Avoid disassembly the valve in an area defined as a potentially explosive atmosphere because the valve is electrically isolated when it has not a drive.

8.7.1. Disassembly

1. Remove the plug (07B,07C) from the top part of the handle (04,04A).
2. Loosen the screws (23B) and remove the handle (04,04A).
3. In the case of the multiposition handle, remove the positioner (56) using a screwdriver as a lever.

8.7.2. Assembly

1. In the case of the multiposition handle, place the positioner (56).
2. Place the handle (04,04A) into the disc shaft (03) positioning the handle arm aligned with the disc and tighten the screw (23B).
3. Place the plug at the top part (07B,07C) of the handle.

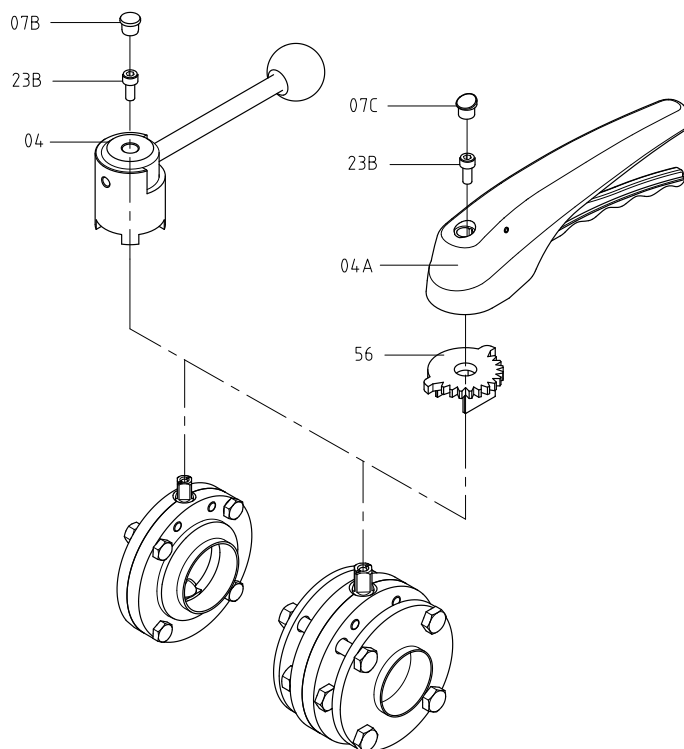

10.010.32.0025

8.8. DISASSEMBLY AND ASSEMBLY OF THE PNEUMATIC DRIVE



When the valve is supplied without manual drive, actuator or head control and the customer want to install one of them, they will have to fulfil with the regulations of the ATEX Directive 2014/34/UE.

Avoid disassembly the valve in an area defined as a potentially explosive atmosphere because the valve is electrically isolated when it has not a drive.

8.8.1. Disassembly

1. Disconnect the compressed air from the actuator.
2. Loosen the two upper screws (23C) which join the actuator support (21) from the laterals (02) or flange laterals (02A).
3. Separate the support actuator assembly from the laterals (02) or flange laterals (02A).
4. Remove the screws (23D) and separate the actuator support (21).
5. Remove the position indicator (58) from the shaft (03).

8.8.2. Assembly

1. Fit the actuator support (21) and tighten the screws (23D).
2. Place the position indicator (58) into the disc shaft (03) and place the actuator (10) as indicated in chapter 8.10. [Actuator fitting options](#).
3. Mount the two screws (23C) that joint the actuator support (21) from the laterals (02) or the flange laterals (02A). Check the position of the actuator and loosen the screws (23C) if necessary. Once the actuator is in place, tighten the screws.

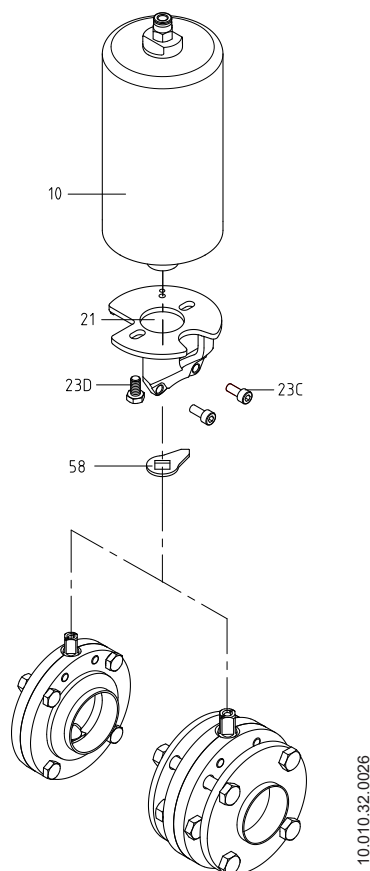

8.9. FITTING THE SEAT SEAL



Carry out the assembly with care avoiding any deterioration of the seat seal. Make sure that all parts are in perfect condition and free from any dirt.

1. Lubricate the disc shaft and the seat seal with the grease indicated in chapter 8.2.1. **Maintenance of the seals.**

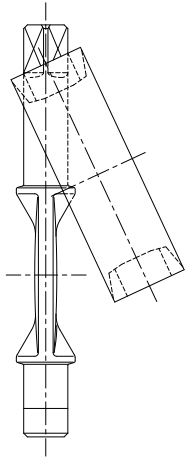

10.010.32.0011

2. Insert the long disc spindle into one of the seal holes.

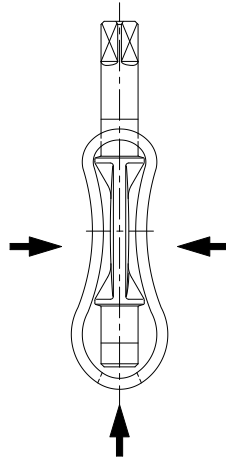

10.010.32.0012

3. Stretch the seal as shown in the drawing, in such a way that it is possible to insert the short spindle in the free gasket hole.

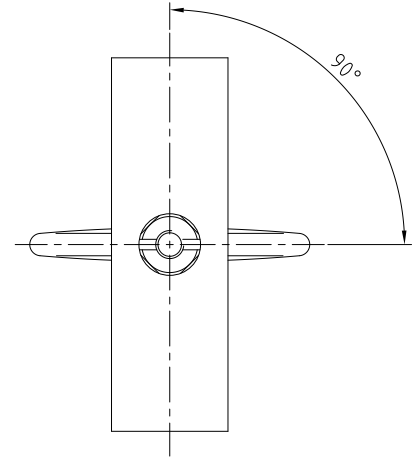

10.010.32.0013

4. Turn the disc until it is perpendicular to the seal. This position facilitates its assembly in the body of the valve.

8.10. ACTUATOR FITTING OPTIONS

1. NC air/spring (normally closed). The disc (03) and the position indicator (58) should be in the closed position (see figure 1).

2. NO air/spring (normally open). The disc (03) and the position indicator (58) should be in the open position (see figure 2).

3. A/A Double effect. The disc (03) and the position indicator (58) should be in the open position (see figure 5.3). Before assembly, supply compressed air in the lower connection of the actuator.

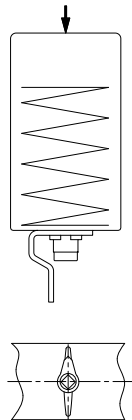

figure 1

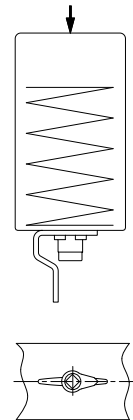

figure 2

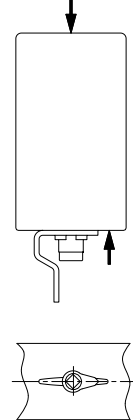

figure 3

10.110.32.0036

8.11. VALVE POSITION

To check if the valve is open or closed during the assembly, the disassembly or the replacement of the handle or the actuator the position of the shaft should be verified

At the upper part of the shaft there is a groove. It indicates the position of the valve:

- open valve: the groove is in line of the fluid circulation
- closed valve: the groove cuts the fluid circulation

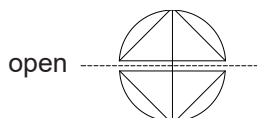

www.sks-online.com

10.010.32.0015

9. Technical Specifications

9.1. VALVE

Maximum working pressure	1000 kPa (10 bar)
Minimum working pressure	20 kPa (0,2 bar)
Maximum working temperature product in ATEX area	108°C (226°F) for gas / 125°C (257°F) for dust
Maximum ambient temperature in ATEX area	-20°C to 40°C (-4°F to 104°C)
Maximum working temperature	121°C (250°F) EPDM seals (for highers temperatures other grades of seals will be used)



The range of maximum temperature in areas defined as potentially explosive for gas should take into account the grade of protection T4:

- temperature range of the product: -20°C to 108°C
- ambient temperature range : -20°C to 40°C

The maximum temperature of the product in areas defined as potentially explosive due to dust is 125°C.

9.2. ACTUATOR



The pneumatic actuator cannot exceed 12 cycles per minute under no circumstances to avoid an important increase in temperature.

Compressed air pressure	600 - 800 kPa (6 - 8 bar)
Compressed air quality	Per ISO 8573-1:2010: <ul style="list-style-type: none"> - <u>Solid particulate content</u>: quality class 3, max. particle dimension 5 microns / max. particle density 5 mg/m³. - <u>Water content</u>: quality class 4, max dew point +2°C. If the valve is used at high altitude or under low ambient temperature conditions, the dew point must be adjusted accordingly. - <u>Oil content</u>: quality class 5, preferentially oil free, max. 25 mg oil per 1m³ air.

Compressed air fitting	G 1/8
Compressed air consumption (litres N/cycle of P _{rel} = 6 bar)	

Actuator	SE (single effect)	DE (double effect)
A940 - T1	1,3	3,4
A940 - T2	2,1	4,9

Valve	A940 - T1	A940 - T2
A480 / A490	DN 25 a 50	DN 65 a 100
	OD 1" a 2"	OD 2½" a 4"

9.3. MATERIALS

Parts in contact with the product	1.4404 (AISI 316L)
Other steel parts	1.4301 (AISI 304)
Seals in contact with the product	EPDM, FPM, HNBR or VQM
Internal surface finish	Ra ≤ 0,8 μm
External surface finish	Mechanized

9.4. SIZES AVAILABLE

DIN EN 10357 serie A <small>(formerly DIN 11850 series 2)</small>	DN 25 - DN 100 (SMS 104)
ASTM A269/270 <small>(correspond to tubo OD)</small>	OD 1" - OD 4" (SMS 25 - SMS 101,6)
Connections	Weld, male, nut, clamp

9.5. TIGHTENING TORQUE

Valve size	Fixed spanner	Tightening torque (Nm)
DN 25 a 100	13	21
OD 1" a 4"	13	21

9.6. WEIGHT OF THE BUTTERFLY VALVE A480

WEIGHT (kg)						
DN	Valve ¹	Two positions handle ²	Multiposition handle ²	Actuator ²	Actuator + C-TOP S ²	
DIN	25	0,9	1,4	1,1	3,2	3,7
	32	1,0	1,5	1,2	3,3	3,8
	40	1,2	1,6	1,3	3,4	3,9
	50	1,4	1,9	1,6	3,6	4,2
	65	1,8	2,3	2,0	5,1	5,6
	80	2,3	2,7	2,4	5,6	6,1
	100	2,9	3,3	3,0	6,2	6,7
	OD	1"	0,8	1,3	1,0	3,1
1½"		1,0	1,5	1,2	3,3	3,8
2"		1,3	1,7	1,4	3,5	4,0
2½"		1,5	2,0	1,7	4,8	5,3
3"		1,8	2,2	1,9	5,1	5,6
4"		2,9	3,4	3,1	6,2	6,8

1) connection weld/weld

2) weight of the valve and drive

9.7. WEIGHT OF THE BUTTERFLY VALVE BETWEEN FLANGES VALVE A490

WEIGHT (kg)						
DN	Valve ¹	Two positions handle ²	Multiposition handle	Actuator	Actuator + C-TOP S	
DIN	25	1,4	1,9	1,6	3,7	4,2
	32	1,6	2,1	1,8	3,8	4,4
	40	1,8	2,3	2,0	4,1	4,6
	50	2,2	2,7	2,4	4,5	5,0
	65	2,8	3,3	3,0	6,1	6,7
	80	3,7	4,1	3,8	7,0	7,5
	100	4,6	5,0	4,7	7,9	8,4
	OD	1"	1,3	1,7	1,4	3,5
1½"		1,6	2,1	1,8	3,9	4,4
2"		2,0	2,5	2,2	4,3	4,8
2½"		2,4	2,8	2,5	4,6	5,1
3"		3,0	3,4	3,1	5,2	5,7
4"		4,7	5,2	4,9	7,0	7,5

1) connection weld/weld

2) weight of the valve and drive

9.8. DIMENSIONS OF THE BUTTERFLY VALVE A480 WITH TWO POSITIONS HANDLE

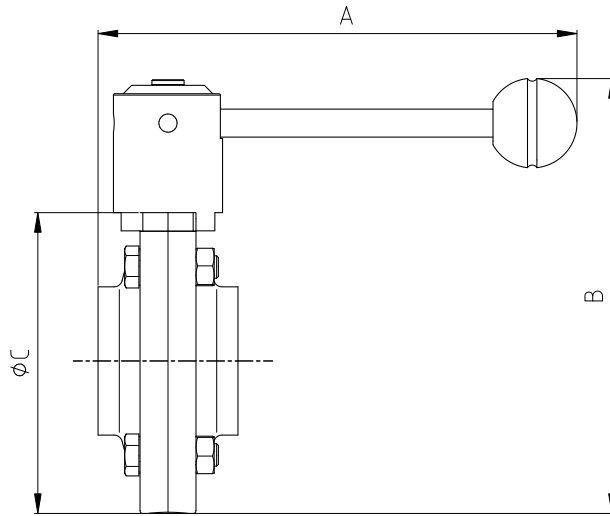

DN	Dimensions		
	A	B	ØC
25	171	130	83
32	171	136	89
40	171	143	96
DIN 50	171	155	109
65	171	173	126
80	205	187	141
100	205	208	161
<hr/>			
OD 1"	171	125	78
1½"	171	138	91
2"	171	150	104
2½"	171	162	116
3"	171	176	129
4"	205	208	161

9.9. DIMENSIONS OF THE BUTTERFLY VALVE BETWEEN FLANGES A490 WITH TWO POSITIONS HANDLE

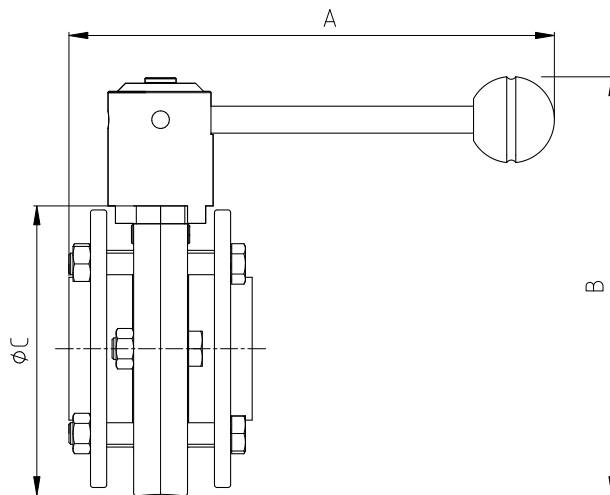

DN	Dimensions		
	A	B	ØC
25	180	130	83
32	180	136	89
40	180	143	96
DIN 50	180	155	109
65	180	173	126
80	211	187	141
100	211	208	161
<hr/>			
OD 1"	180	125	78
1½"	180	138	91
2"	180	150	104
2½"	180	162	116
3"	182	176	129
4"	211	208	161

9.10. DIMENSIONS OF THE BUTTERFLY VALVE A480 WITH MULTIPOSITION HANDLE

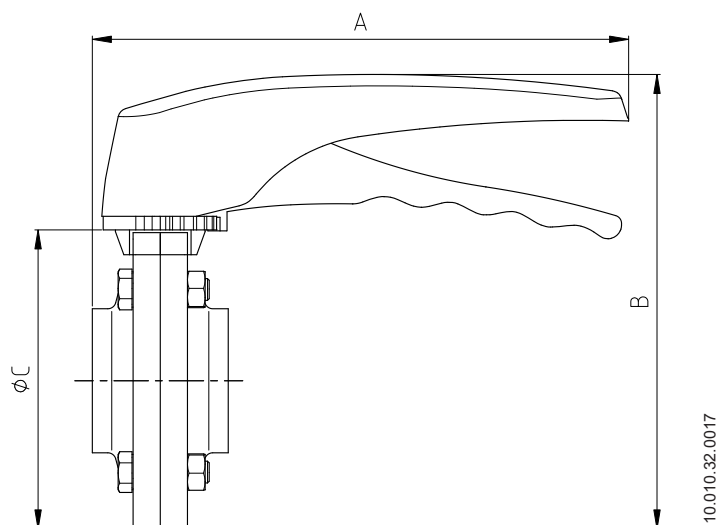

DN	Dimensions		
	A	B	ØC
25	198	142	83
32	198	148	89
40	198	155	96
50	198	167	109
65	198	185	126
80	203	200	141
100	203	220	161
<hr/>			
1"	198	137	78
1½"	198	150	91
2"	198	162	104
2½"	198	175	116
3"	198	188	129
4"	203	220	161

9.11. DIMENSIONS OF THE BUTTERFLY VALVE BETWEEN FLANGES A490 WITH MULTIPOSITION HANDLE

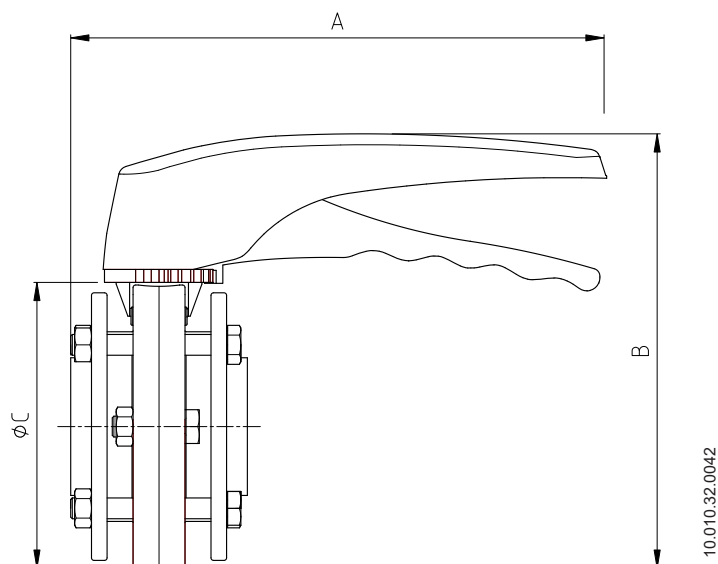

DN	Dimensions		
	A	B	ØC
25	207	142	83
32	207	148	89
40	207	155	96
50	207	167	109
65	207	185	126
80	209	200	141
100	209	220	161
<hr/>			
1"	207	137	78
1½"	207	150	91
2"	207	162	104
2½"	207	175	116
3"	209	188	129
4"	209	220	161

9.12. DIMENSIONS OF THE BUTTERFLY VALVE A480 WITH ACTUATOR

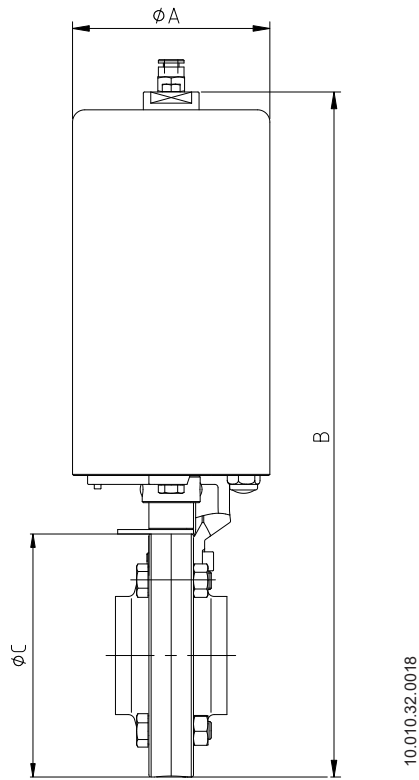

DN	Dimensions		
	ØA	B	ØC
25	76	260	83
32	76	266	89
40	76	273	96
50	76	286	109
65	89	325	126
80	89	340	141
100	89	360	161
<hr/>			
1"	76	255	78
1½"	76	268	91
2"	76	281	104
2½"	89	315	116
3"	89	328	129
4"	89	360	161

10.010.32.0018

9.13. DIMENSIONS OF THE BUTTERFLY VALVE BETWEEN FLANGES A490 WITH ACTUATOR

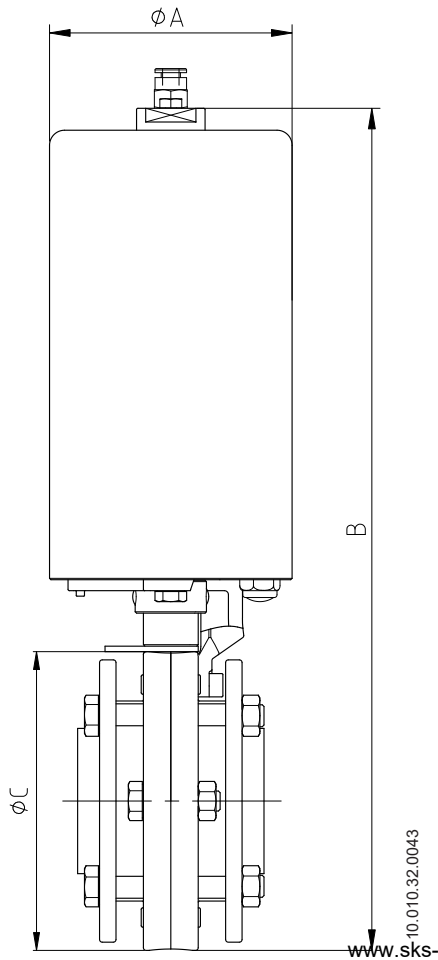

DN	Dimensions		
	ØA	B	ØC
25	76	260	83
32	76	266	89
40	76	273	96
50	76	286	109
65	89	325	126
80	89	340	141
100	89	360	161
<hr/>			
1"	76	255	78
1½"	76	268	91
2"	76	281	104
2½"	89	315	116
3"	89	328	129
4"	89	360	161

10.010.32.0043

www.sks-online.com

9.14. DIMENSIONS OF THE BUTTERFLY VALVE A480 WITH ACTUATOR AND C-TOP S

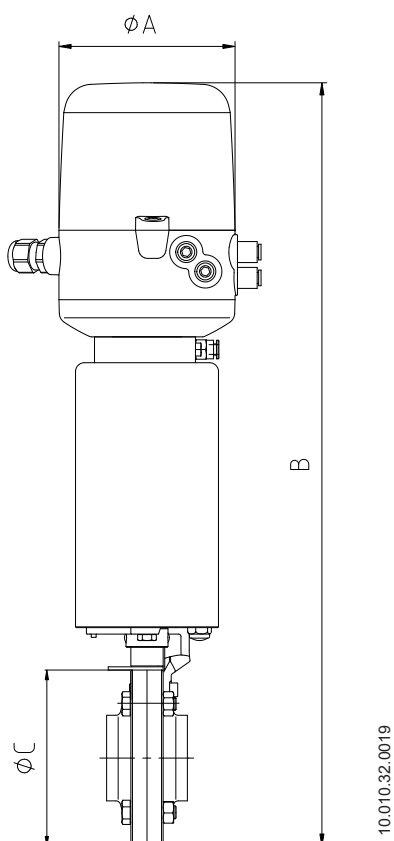

DN	Dimensions		
	ØA	B	ØC
25	109	467	83
32	109	476	89
40	109	486	96
DIN 50	109	506	109
65	109	554	126
80	109	576	141
100	109	607	161
OD 1"	109	420	78
1½"	109	433	91
2"	109	446	104
2½"	109	480	116
3"	109	493	129
4"	109	525	161

9.15. DIMENSIONS OF THE BUTTERFLY VALVE BETWEEN FLANGES A490 WITH ACTUATOR AND C-TOP S

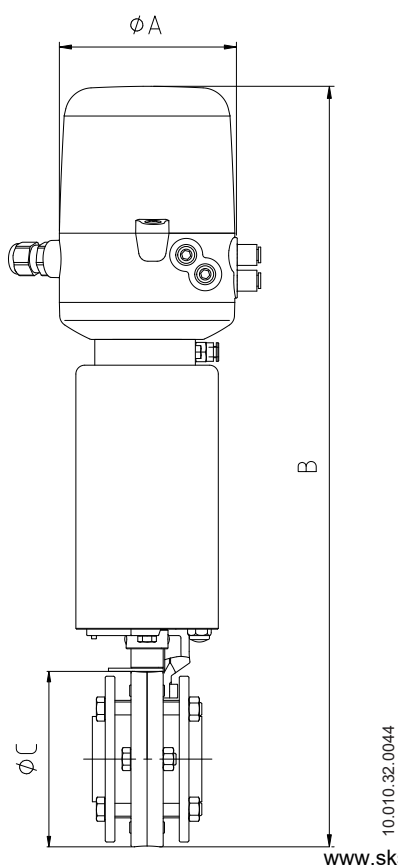

DN	Dimensions		
	ØA	B	ØC
25	109	467	83
32	109	476	89
40	109	486	96
DIN 50	109	506	109
65	109	554	126
80	109	577	141
100	109	607	161
OD 1"	109	420	78
1½"	109	433	91
2"	109	446	104
2½"	109	480	116
3"	109	493	129
4"	109	525	161

www.sks-online.com

9.16. EXPLODED DRAWING AND PARTS LIST OF THE BUTTERFLY VALVE A480

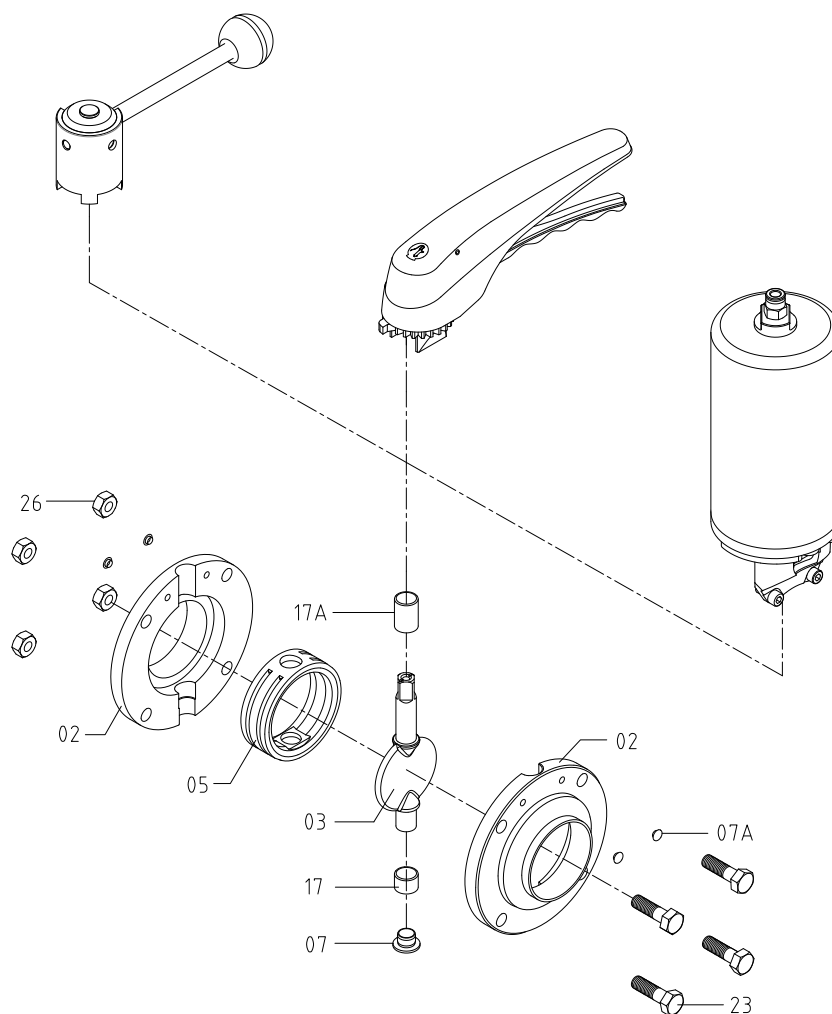

10.010.32.0033

Position	Description	Quantity	Material
02	lateral	2	1.4307 (AISI 304L)
03	disc ¹	1	1.4404 (AISI 316L)
05	seat seal ¹	1	EPDM-FPM-HNBR-VMQ
07	bottom protective plug	1	plastic
07A	protective plug lateral	4	plastic
17	guide bushing ¹	1	Iglidur G
17A	guide bushing ¹	1	Iglidur G
23	hexagonal screw	4	A2
26	nut	4	A2

1) Recommended spare parts

9.17. EXPLODED DRAWING AND PARTS LIST OF THE BUTTERFLY VALVE BETWEEN FLANGES A490

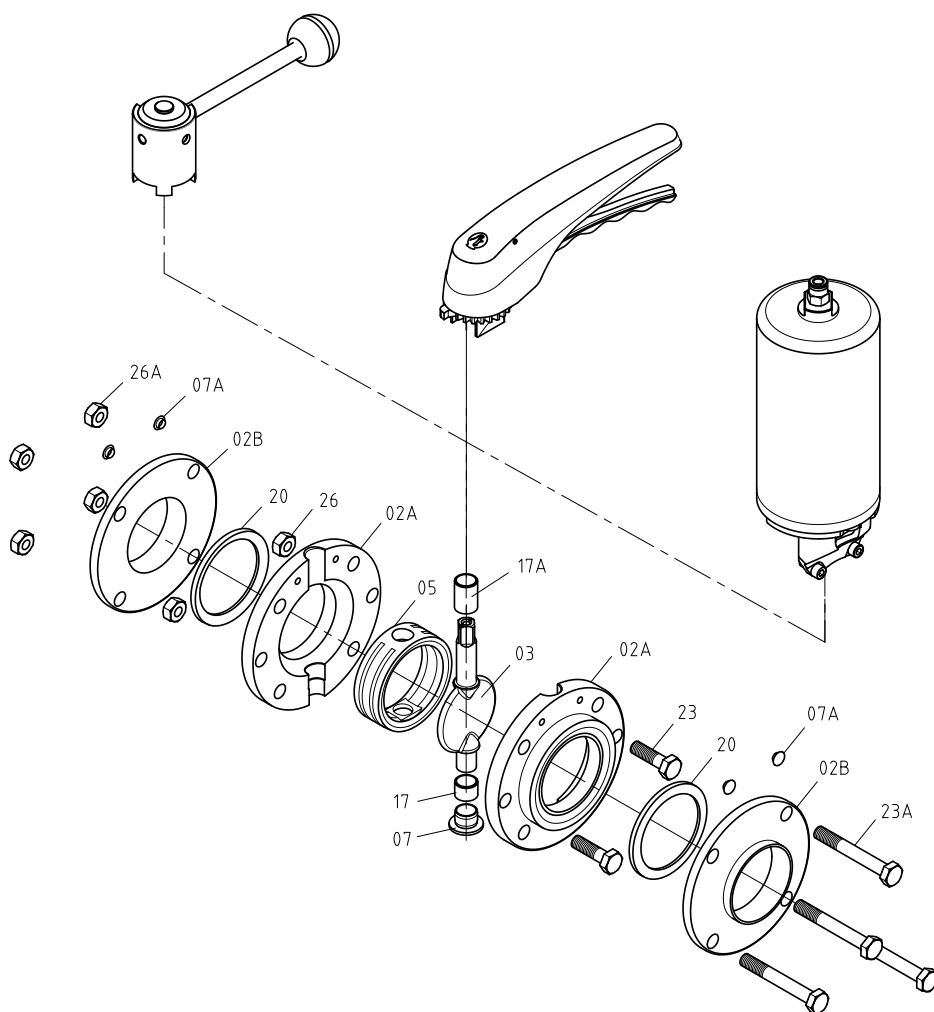

Position	Description	Quantity	Material
02A	flange laterals	2	1.4307 (AISI 304L)
02B	flange	2	1.4307 (AISI 304L)
03	disc ¹	1	1.4404 (AISI 316L)
05	seat seal ¹	1	EPDM-FPM-HNBR-VMQ
07	bottom protective plug	1	plastic
07A	protective plug flange laterals	4	plastic
17	guide bushing ¹	1	Iglidur G
17A	guide bushing ¹	1	Iglidur G
20	flange seal ¹	2	EPDM-FPM-HNBR-VMQ
23	hexagonal screw	2	A2
23A	hexagonal screw	4	A2
26	nut	2	A2
26A	nut	4	A2

1) Recommended spare parts

9.18. EXPLODED DRAWING AND PARTS LIST OF THE BUTTERFLY VALVE'S DRIVES A480 / A490

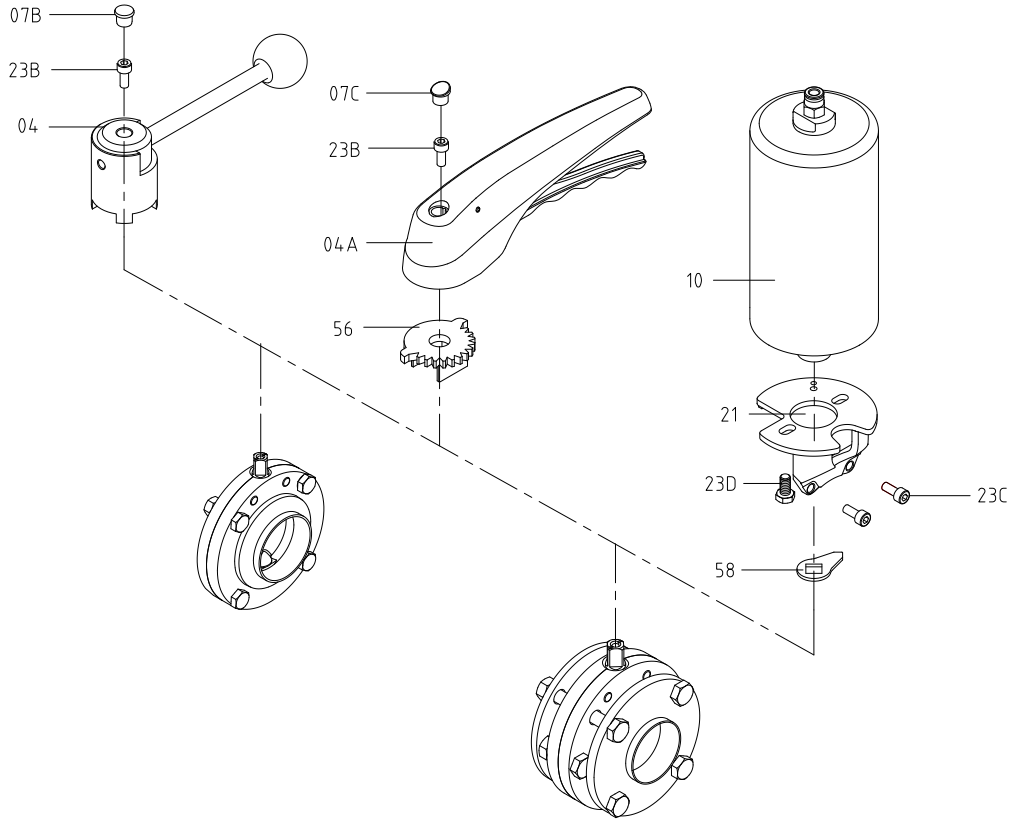

10.010.32.0053

Position	Description	Quantity	Material
04	two positions handle	1	1.4301 (AISI 304) + plastic (PF31)
04A	multiposition handle	1	1.4301 (AISI 304) +/-or plastic (PA6)
07B	protective plug two positions handle	1	plastic
07C	protective plug multiposition handle	1	plastic
10	actuator	1	1.4301 (AISI 304)
11	two positions handle	1	1.4301 (AISI 304) + plástico (PF31)
21	actuator support	1	1.4307 (AISI 304L)
23B	allen screw	1	A2
23C	allen screw	2	A2
23D	hexagonal screw	1	A2
56	positioner	1	1.4301 (AISI 304)
58	position indicator	1	plastic

NOTES

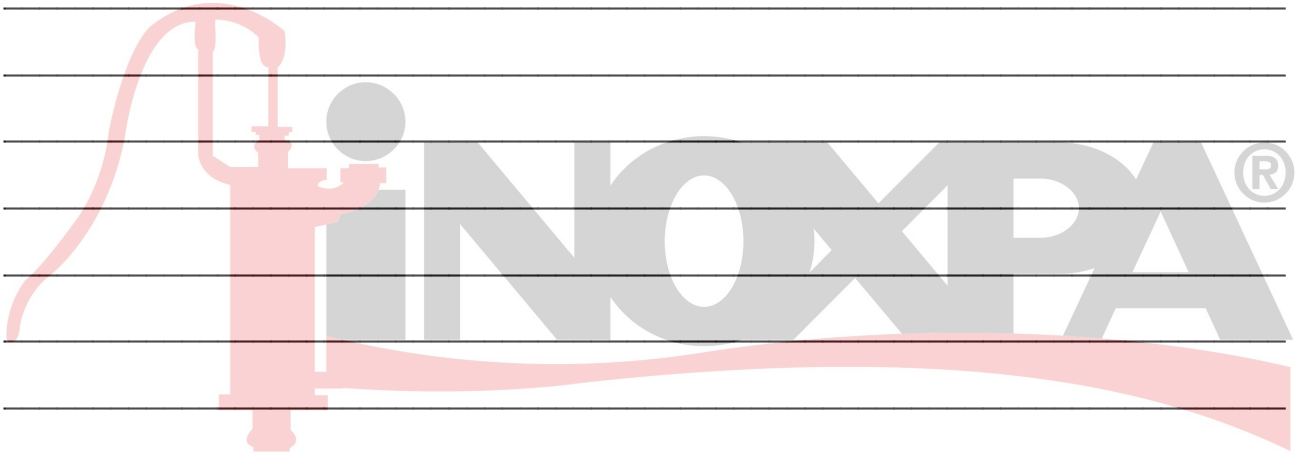

How to contact INOXPA S.A.U.:

Contact details for all countries are continually updated on our website.

Please visit www.inoxpa.com to access the information.



INOXPA S.A.U.
Telers, 60 - 17820 - Banyoles - Spain

www.sks-online.com

